



XD 9005A
SWH03HF02
5/9/2023



XLT Electric Oven & XLT Hood Installation & Operation Manual



CAUTION

Read This Manual Before Using This Appliance.

Current versions of this manual, Technical/Rough-In Specifications, Parts and Service Manual, Fire Suppression Installation, Architectural Drawings, and a list of International Authorized Distributors are available at:

www.xltovens.com

For use with the following XLT Electric Oven Versions:
Standard (S) H
World (W) H

For use with the following XLT Electric Hood Versions:
Standard (S) F
World (W) F



Original Instructions

XLT Ovens
PO Box 9090
Wichita, Kansas 67277

US: 888-443-2751 FAX: 316-943-2769 INTL: +1-316-943-2751 WEB: www.xltovens.com

**FOR YOUR SAFETY**

Do not store or use gasoline or other flammable vapors and liquids on the vicinity of this or any other appliance.



Improper installation, adjustment, alteration, service or maintenance can cause property damage, injury, or death. Read the installation, operating and maintenance instructions thoroughly before installing or servicing this equipment.



This appliance is not intended for use by persons (including children) with reduced physical, sensory or mental capabilities, or lack of experience and knowledge, unless they have been given supervision or instruction concerning use of the appliance by a person responsible for their safety.

XLT has spent millions of dollars designing and testing our products as well as developing Installation and Operation Manuals. These manuals are the most complete and easiest to understand in the industry. However, they are worthless if they are not followed.

We have witnessed store operators and building owners lose many thousands of dollars in lost revenue due to incorrect installations. We highly recommend you follow all instructions given in this manual as well as follow best practices in plumbing, electrical, and HVAC building codes.

Revision History Table

Revision	Comments	Date
A	New Release - H Oven F Hood - Shroud Assembly Updates	05/23/2023

Definitions and Symbols

A safety instruction (message) includes a “Safety Alert Symbol” and a signal word or phrase such as **DANGER**, **WARNING** or **CAUTION**. Each signal word has the following meaning:

 DANGER	ISO 7000-0434: This symbol indicates a potentially hazardous situation that, if not avoided, can result in serious injury or death.
--	---

 HIGH VOLTAGE	IEC 60417-5036: This symbol indicates a high voltage. It calls your attention to items or operations that could be dangerous to you and other persons operating this equipment. Read the message and follow the instructions carefully.
--	---

 WARNING	ISO 7000-0434: This symbol indicates a potentially hazardous situation, that if not avoided, can result in cuts or being crushed. It calls your attention to items or operations that could be dangerous to you and other persons operating this equipment.
---	---





 CAUTION	ISO 7000-0434: This symbol indicates a potentially hazardous situation, that if not avoided, can result in minor to moderate injury or serious damage to the product. The situation described in the CAUTION may, if not avoided, lead to serious results. Important safety measures are described in CAUTION (as well as WARNING), so be sure to observe them.
--	---



NOTE indicates an area or subject of special merit, emphasizing either the product’s capability or common errors in operation or maintenance.

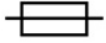

TIP give a special instruction that can save time or provide other benefits while installing or using the product. The tip calls attention to an idea that may not be obvious to first-time users of the product.

 READ MANUAL	ISO 7000-0790: Read the instructions before using this machine.	 CLASS II EQUIPMENT	IEC 60417-5172: A class II or double insulated electrical appliance.
 PROTECTIVE EARTH	IEC 60417-5019: Terminal which is intended for connection to an external conductor.	 EQUIPOTENTIALITY	IEC 60417-5021: Having the same electric potential or uniform electric potential.
 FUSE-LINK	IEC 60417-5016: Terminal which is intended for connection to an external conductor.		



SAFETY DEPENDS ON YOU



This appliance is for professional use by qualified personnel. This appliance must be installed by qualified persons in accordance with the regulations in force. This appliance must be installed with sufficient ventilation to prevent the occurrence of unacceptable concentrations of substances harmful to health in the room in which it is installed. This appliance needs an unobstructed flow of fresh air for satisfactory operation and must be installed in a suitably ventilated room in accordance with current regulations. This appliance should be serviced by qualified personnel at least every twelve (12) months or sooner if heavy use is expected.



Installation and repairs of all electrical appliances and ventilation exhaust hoods should only be performed by a qualified professional who has read and understands these instructions and is familiar with proper safety precautions. Read this manual thoroughly before installing or servicing this equipment.

- Do not restrict the flow of ventilation air to the unit. Provide adequate clearance for operating, cleaning, and maintaining the unit in the installed position.
- Keep the area free and clear of combustible material. DO NOT SPRAY AEROSOLS IN THE VICINITY OF THIS APPLIANCE WHILE IT IS IN OPERATION.
- Ovens are certified for installation on either combustible or non-combustible floors, and adjacent to either combustible or non-combustible walls.
- Electrical schematics are located inside the control box of the oven, in this manual, and online at www.xltovens.com. Disconnect input power to the unit before performing any maintenance.
- This unit requires a ventilation hood that must conform to local codes.
- This unit must be operated by the same voltage, phase, and frequency of electrical power as designated on the data plate located on the side of the unit.
- Minimum clearances must be maintained from combustible and non-combustible construction materials.
- Follow all local codes when installing this unit.
- Follow all local codes to electrically ground the unit.
- Appliance is not to be cleaned with water jet (high pressure water).
- Most XLT ovens are certified for use in stacks of up to four (4) units of XLT products. Integration of other manufacturer's products into an oven stack is not recommended, and voids any warranties. XLT assumes no liability for mixed product applications.
- Failure to call XLT Customer Service at 1-888-443-2751 prior to contacting a repair company voids any and all warranties.
- This appliance operates below 75 dBA.
- PLEASE RETAIN THIS MANUAL FOR FUTURE REFERENCE.

Warning and Safety Information 2

Table of Contents 5

Warranty 6

General 8

Receiving and Inspection 9

Installation Responsibilities 10

Oven Description..... 11

Oven Crate Dimensions..... 13

Oven Dimensions and Weights 14

Oven Requirements 17

Oven Only Rough-In Specifications 18

Oven Assembly 20

Oven Connection..... 27

Oven Fire Suppression 28

Oven Ventilation Guidelines 30

Oven Initial Start-Up..... 31

Oven Operation 32

Oven Operator Controls 33

Oven Cleaning..... 36

Oven Maintenance..... 41

Oven Troubleshooting..... 42

Hood Installation 45

Hood Description 46

Hood and Shroud Crate Dimensions 47

Hood Dimensions and Weights..... 49

Recommended Exhaust Flow Rates 50

Hood Electrical Requirements..... 52

Hood Rough-In Specifications 53

Hood Electrical Connections..... 54

Hood and Shroud Assembly..... 63

Hood Connection..... 72

Hood Initial Start-Up..... 75

Hood Operator Controls 76

Hood Valance Kit..... 77

Hood Duct Wrap Kit 80

Hood Cleaning..... 81

Oven Electrical Schematics..... 84

Hood Electrical Schematics..... 102

Certifications 106

Typical Store Installation 108

Start-Up Checklist 109

Notes..... 110



Warranty - US and Canada

Rev J

Approval Date: 09/22/2022

XLT warrants ovens manufactured after September 22, 2022 to be free from any defect in material and workmanship under normal use for seven (7) years from the date of original purchase by the end user, and further warrants main fan blades, conveyor shafts, and conveyor bearings for ten (10) years. XLT further warrants all ovens/hoods to be free from rust for ten (10) years from the date the equipment is originally purchased. XLT warrants hoods manufactured after September 22, 2022 to be free from any defect in material and workmanship under normal use for seven (7) years from the date of original purchase by the end user purchaser. If the purchase includes a pre-piped Ansul system on both the ovens and hood, the warranty will be increased to ten (10) years on both pieces of equipment. In the event of a part failure, XLT will furnish a replacement part and pay for all labor associated with the replacement of the part. If upon inspection XLT determines that the part is not defective, all incurred costs will be the responsibility of the end user purchaser. This warranty is extended to the original end user purchaser and is not transferable without prior written consent of XLT. Damages are limited to the original purchase price.

DUTIES OF THE OWNER:

- The owner must inspect the equipment and crates at time of receipt. Damage during shipment is to be immediately reported to the carrier, XLT, and documented on the Bill of Lading.
- The equipment must be installed and operated in accordance with the Installation and Operation Manual furnished with the unit.
- This warranty shall not excuse the owner from properly maintaining the equipment in accordance with the Installation and Operation Manual furnished with the unit.
- A copy of the "Initial Start-Up Checklist" must be filled out and returned to XLT when the unit is initially installed, and/or when the unit is removed and installed in another location.
- The gas, electric, and HVAC utilities must be connected to the oven and installed by locally licensed contractors.
- Failure to contact XLT prior to contacting a repair company for warranty work voids any and all warranties.

WHAT IS NOT COVERED:

- Freight damage
- Overtime charges
- Any part that becomes defective because of utility services (power surges, high or low voltages, high or low gas pressure or volume, contaminated fuel, or improper utility connections)
- Any part that becomes defective because of moisture and/or other contaminants
- Conveyor belts
- Filters
- Exhaust Fans
- Light Bulbs
- Painted or Powder Coated surfaces
- Normal maintenance or adjustments
- This warranty shall not apply if the equipment or any part is damaged as a result of accident, casualty, alteration, misuse, abuse, improper cleaning, improper installation, improper operation, natural disasters, or man-made disasters.

CLAIMS HANDLED AS FOLLOWS:

- Should any such defect be discovered, XLT must be notified. Upon notification, XLT will arrange for necessary repairs to be made by an authorized service agent. Denial of services upon the arrival of an authorized service agent will release XLT of any and all warranty obligations.

7761 W Kellogg Drive 67209-2003 - PO Box 9090 67277-0090 - Wichita, Kansas
Voice (316) 943-2751 - (888) 443-2751 - Fax (316) 943-2769
www.xltovens.com





Warranty - International

Rev L

Approval Date: 09/22/2022

XLT warrants ovens manufactured after September 22, 2022 to be free from any defect in material and workmanship under normal use for five (5) years from the date of original purchase by the end user, and further warrants main fan blades, conveyor shafts, and conveyor bearings for ten (10) years. XLT further warrants all ovens/hoods to be free from rust for ten (10) years from the date the equipment is originally purchased. XLT warrants hoods manufactured after September 22, 2022 to be free from any defect in material and workmanship under normal use for five (5) years from the date of original purchase by the end user purchaser. If the purchase includes a hood and the ovens both the warranty will be increased to seven (7) years on both pieces of equipment. In the event of a part failure, XLT will furnish a replacement part and pay for all labor associated with the replacement of the part. If upon inspection XLT determines that the part is not defective, all incurred costs will be the responsibility of the end user purchaser. This warranty is extended to the original end user purchaser and is not transferable without prior written consent of XLT. Damages are limited to the original purchase price.

DUTIES OF THE OWNER:

- The owner must inspect the equipment and crates at time of receipt. Damage during shipment is to be immediately reported to the carrier and also to the Distributor/Service Provider.
- The equipment must be installed and operated in accordance with the Installation and Operation Manual furnished with the unit.
- This warranty shall not excuse the owner from properly maintaining the equipment in accordance with the Installation and Operation Manual furnished with the unit.
- A copy of the "Initial Start-Up Checklist" must be filled out and returned to Distributor/Service Provider and to XLT when the unit is initially installed, and/or when the unit is removed and installed in another location.
- The gas, electric, and HVAC utilities must be connected to the oven and installed by locally licensed contractors.
- Failure to contact the Distributor/Service Provider prior to contacting a repair company for warranty work voids any and all warranties.

WHAT IS NOT COVERED:

- Freight damage
- Overtime charges
- Any part that becomes defective because of utility services (power surges, high or low voltages, high or low gas pressure or volume, contaminated fuel, or improper utility connections)
- Any part that becomes defective because of moisture and/or other contaminants
- Conveyor belts
- Filters
- Exhaust Fans
- Light Bulbs
- Painted or Powder Coated surfaces
- Normal maintenance or adjustments
- This warranty shall not apply if the equipment or any part is damaged as a result of accident, casualty, alteration, misuse, abuse, improper cleaning, improper installation, improper operation, natural disasters, or man-made disasters.

CLAIMS HANDLED AS FOLLOWS:

- Should any such defect be discovered, the Distributor/Service Provider must be notified. Upon notification, Distributor/Service Provider will arrange for necessary repairs to be made by an authorized service agent. Denial of services upon the arrival of an authorized service agent will release XLT and Distributor/Service Provider of any and all warranty obligations.



Save This Manual

This document is the property of the owner of this equipment.

XLT reserves the right to make changes in design and specifications, and/or make additions to or improvements to its product without imposing any obligations upon itself to install them in products previously manufactured.

All Right Hand and Left Hand designations in this manual are from the point of view as seen below.

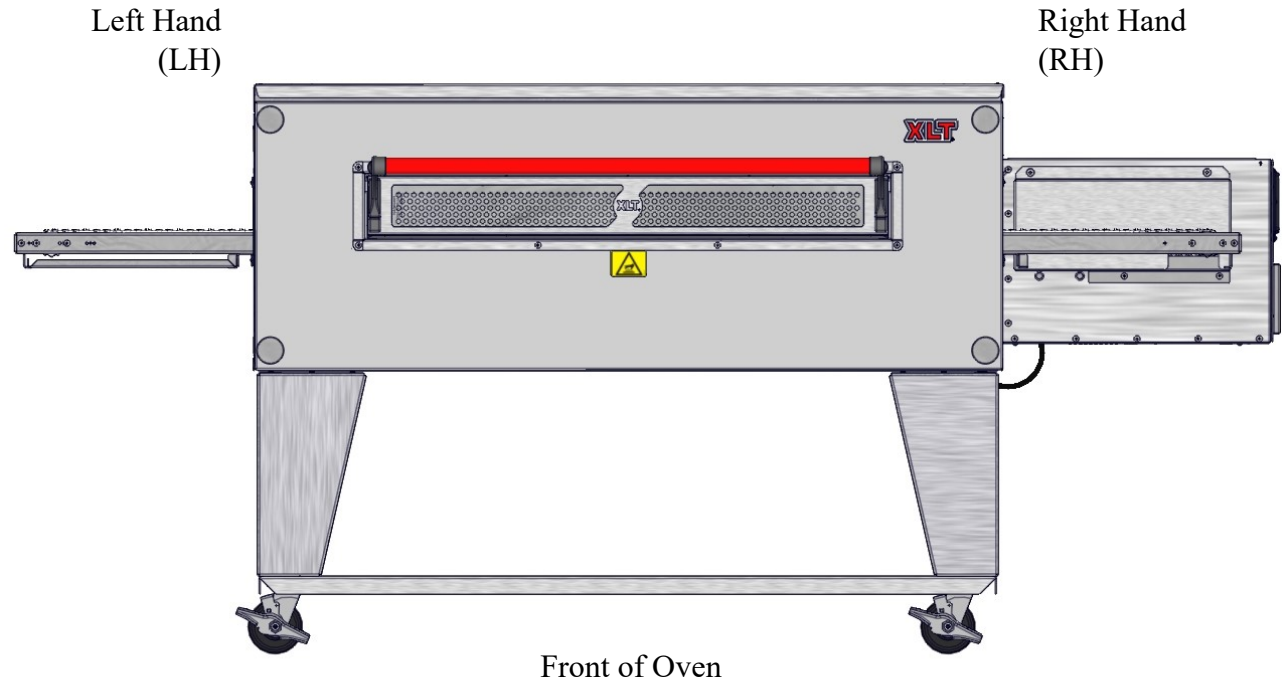

Notify Carrier of Damage at Once

Upon receiving of all goods shipped by a Common Carrier, check for any exterior damage that may indicate interior damage. If conditions permit, open all crates and do a full inspection for any damage while the delivery driver is still there. If there is damage, please note on the delivery receipt and call the carrier to make a freight damage claim within 24 hours of receipt. Failure to make a damage claim within the first 24 hours may void the opportunity to have the claim resolved.

XLT wants you to be totally satisfied with every aspect of owning and using your oven and hood. Your feedback, both positive and negative, is very important to us as it helps us understand how to improve our products and our company. Our goal is to provide you with equipment that we are proud to build and you will be proud to own.

To receive technical support for the oven or hood you purchased, XLT has qualified customer service personnel that can provide assistance on any type of XLT equipment problem you may experience. Customer Service is available 24/7/365 at 888-443-2751 or visit www.xltovens.com.

Responsibility	Service Company	Owner/ Contractor
Site Survey: Verify electric and gas meter/regulator sizes	X	
Supply wiring from TS1 #R3, R4, R5 to exhaust fan		X
Assembly of new hood per XLT Installation & Operation Manual		X
Suspend XLT Hood from ceiling		X
Weld ducting to XLT Hood		X
Install new exhaust fan on roof		X
Supply power to XLT Hood		X
Install Duct Cover or Valance above XLT Hood		X
Supply wiring from TS1 R3, R4, R5 to exhaust fan		X
Assemble upper and lower shroud assemblies	X	
Install shrouds assembly	X	
Assembly of new ovens per XLT Installation & Operation Manual	X	
Bases assembled and set in place	X	
Supply power to XLT Oven(s)	X	
Ovens moved and stacked with proper lifting equipment	X	
Peel all PVC	X	
Assemble shrouds & brackets to XLT Oven/Hood	X	
Install FS to oven	X	
Connection may require Permit and Code Inspections		X
Relocate Make-Up-Air to enter the room at the ends of the Ovens		X
Start-up per XLT Installation & Operation Manual:	X	
Start-Up Checklist has been filled out per Installation & Operation Manual	X	
Start-Up Checklist must be submitted to XLT to validate Warranty		X



If XLT employees are completing the installation process, they will be considered a Service Company in regards to the above table.

This manual covers the following XLT Oven and Hood models:

Ovens	Hood/Shroud Package	Hood Size	Shroud Size
X3H-1832-xxxxx	02-9F-1832-xxxxx	1832	1832
X3H-2336-xxxxx	02-9F-2336-xxxxx	2440	2336
X3H-2440-xxxxx	02-9F-2440-xxxxx	2440	2440
X3H-3240-xxxxx	02-9F-3240-xxxxx	3240	3240
X3H-3250-xxxxx-DS	02-9F-3250-xxxxx	3255	3250DS
X3H-3255-xxxxx	02-9F-3255-xxxxx	3255	3255
X3H-3855-xxxxx	02-9F-3855-xxxxx	3855	3855
X3H-4455-xxxxx	02-9F-4455-xxxxx	4455	4455

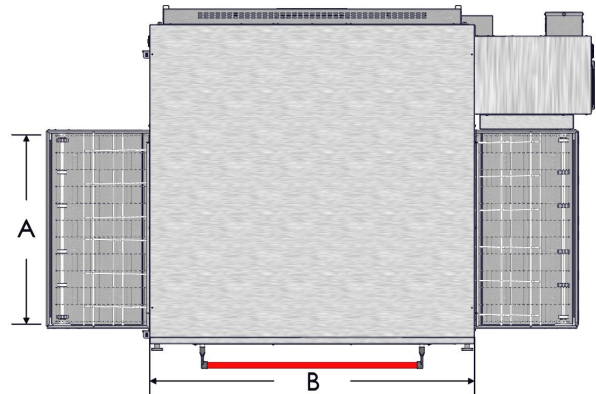

The first two (2) digits of the model number after the dash represent the conveyor width and the last two (2) digits indicate the bake chamber length. For example, the X3H-3255-xxxx models would have a bake chamber with the width (A in image above) of 32 inches and the length (B in the image above) of 55 inches. The five (5) x's after those numbers represent the oven and hood configuration number. The DS models, noted at end of model number, may be used in a single or double stack configuration only. All other ovens may be used in a single, double, triple, or quad stack configuration. All models have a single control box, which can be mounted on either the right-hand or left-hand side, and are heated by electric elements (Gas ovens are also available in a variety of sizes). All models can be configured for a split belt conveyor.

Oven Description

Food product is placed on the stainless steel wire conveyor belt on one side of the oven. The conveyor then transports the food through the bake chamber at a user-controlled speed. This provides repeatable and uniform food cooking. The conveyors can be easily configured to move either left-to-right or right-to-left with a simple programming change. A large optional center sandwich door allows the introduction of food items for cooking at shorter times. Precise temperatures are user adjustable and maintained by a digital control.

An easily removable front panel allows the full cleaning of the oven interior. All exposed oven surfaces both exterior and interior are stainless steel. The conveyor is a one piece design and is removed from the side which has the control box. The oven itself is mounted on lockable swivel casters for easy moving and maintenance.

XLT has available a variety of accessories for use with the ovens and hoods as well as the installation and moving of the equipment. Please contact XLT or your Authorized Distributor for more information.

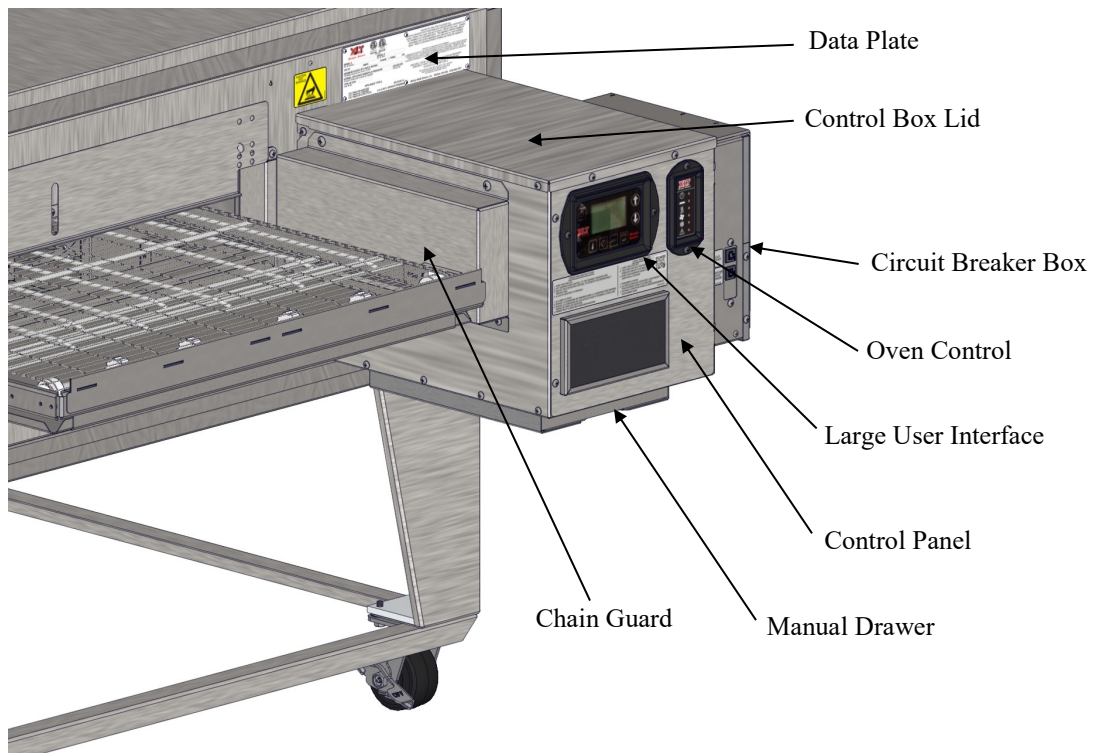
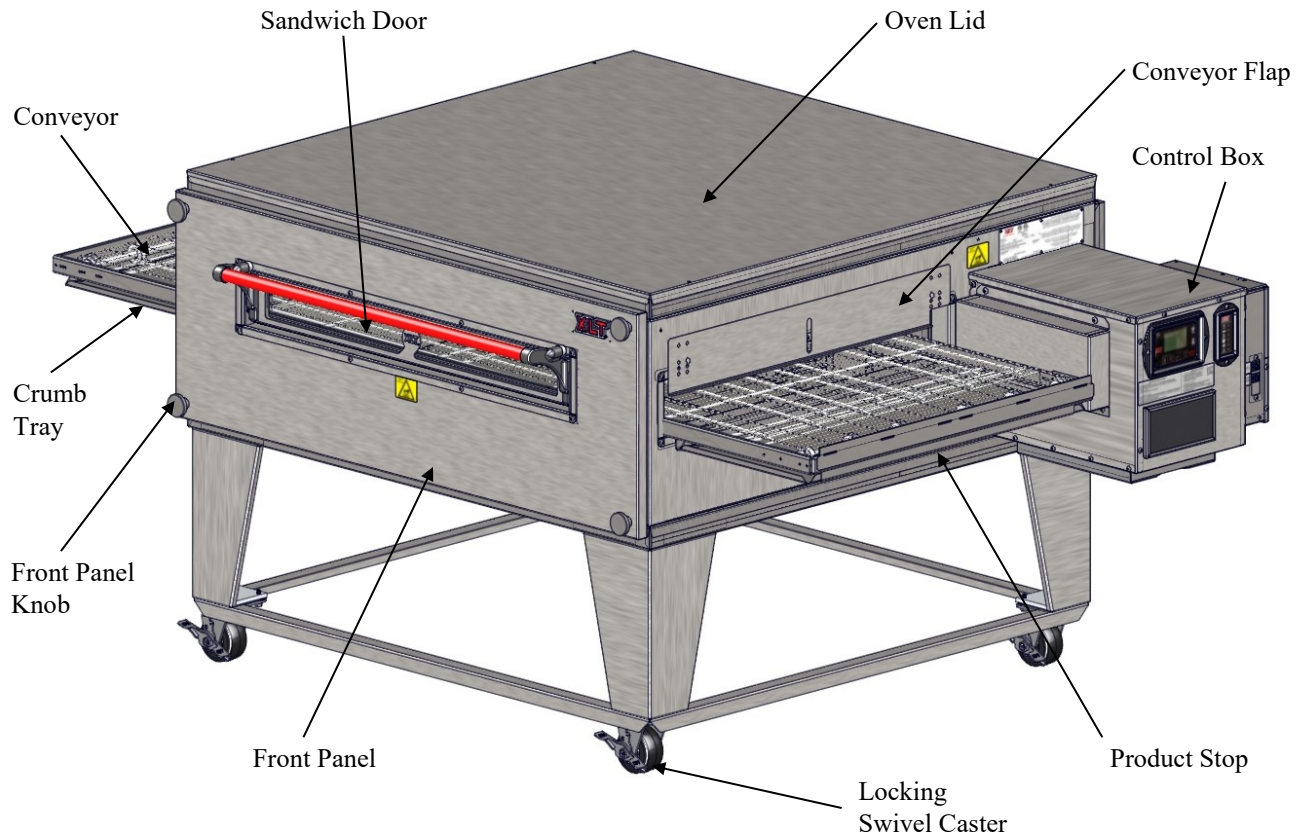

Domestic Wood Crate Pallets

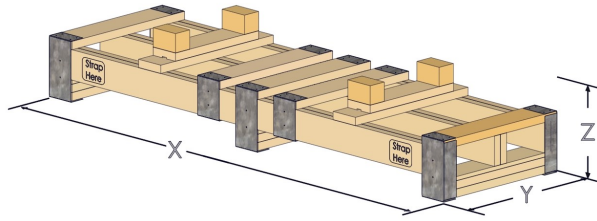

Domestic Wood Crate Dimensions				
Oven Model	Electric Oven			
	X	Y	Z	Z (With Oven)
1832	85 5/8 [2175]	31 5/8 [803]	17 1/4 [438]	59 3/4 [1518]
2336	85 5/8 [2175]	31 5/8 [803]	17 1/4 [438]	63 1/2 [1613]
2440	85 5/8 [2175]	31 5/8 [803]	17 1/4 [438]	65 3/4 [1670]
3240	85 5/8 [2175]	31 5/8 [803]	17 1/4 [438]	73 3/4 [1873]
3250-DS	85 5/8 [2175]	37 5/8 [956]	17 1/4 [438]	73 3/4 [1873]
3255	115 5/8 [2937]	31 5/8 [803]	17 1/4 [438]	73 3/4 [1873]
3855	115 5/8 [2937]	31 5/8 [803]	17 1/4 [438]	79 3/4 [2026]
4455	115 5/8 [2937]	31 5/8 [803]	17 1/4 [438]	85 3/4 [2178]

International Wood Crates

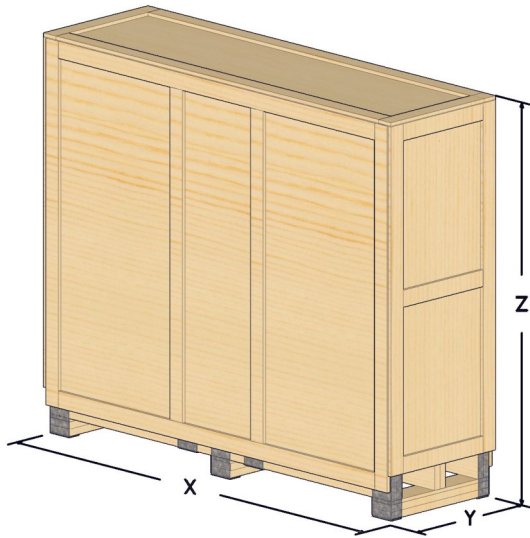

International Wood Crate Dimensions			
Oven Model	Electric Ovens		
	X	Y	Z
1832	76 [1930]	29 3/4 [756]	63 1/2 [1613]
2336	84 [2134]	29 3/4 [756]	69 1/2 [1765]
2440	84 [2134]	29 3/4 [756]	69 1/2 [1765]
3240	84 [2134]	29 3/4 [756]	77 1/2 [1969]
3250-DS	84 [2134]	35 3/4 [908]	77 1/2 [1969]
3255	99 [2515]	29 3/4 [756]	77 1/2 [1969]
3855	99 [2515]	29 3/4 [756]	83 1/2 [2121]
4455	99 [2515]	29 3/4 [756]	85 1/2 [2172]

Metal Skids (Containers Only)

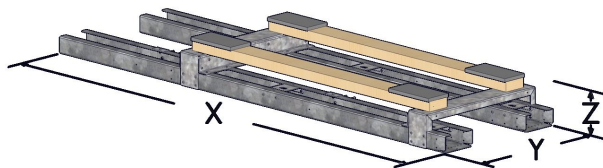

Metal Skid Dimensions				
Oven Model	Electric Oven			
	X	Y	Z	Z (With Oven)
1832	55 [1397]	21 6/7 [555]	6 1/2 [165]	49 [1245]
2336	59 [1499]	21 6/7 [555]	6 1/2 [165]	52 3/4 [1340]
2440	63 [1600]	21 6/7 [555]	6 1/2 [165]	55 [1397]
3240	63 [1600]	21 6/7 [555]	6 1/2 [165]	63 [1600]
3250-DS	68 [1727]	27 2/3 [704]	8 5/8 [219]	65.125 [1654]
3255	78 [1981]	21 6/7 [555]	6 1/2 [165]	63 [1600]
3855	78 [1981]	21 6/7 [555]	6 1/2 [165]	69 [1753]
4455	78 [1981]	21 6/7 [555]	6 1/2 [165]	75 [1905]

NOTE: All dimensions in inches [millimeters], ± 1/4 [6], unless otherwise noted.

Single Stack

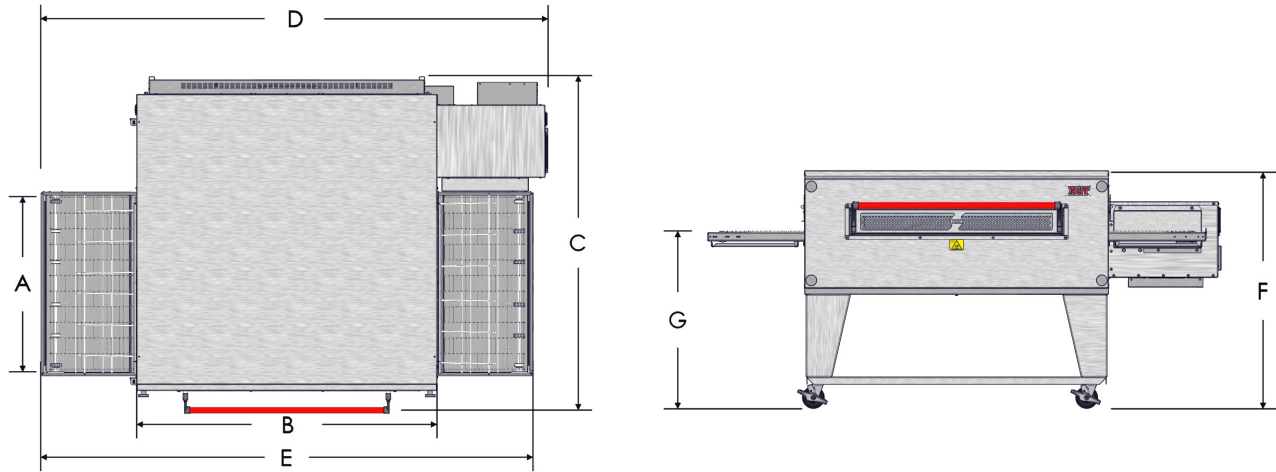

SINGLE OVEN	A	B	C	D	E	F	G	OVEN WEIGHT	CRATED WEIGHTS		
									DOM. WOOD	INTL. WOOD	METAL SKID
1832	18 [457]	32 [813]	47 5/6 [1215]	70 1/4 [1784]	67 1/4 [1708]	43 [1092]	32 [813]	568 [258]	765 [347]	802 [364]	688 [312]
2336	23 [584]	36 [914]	51 [1295]	70 1/4 [1784]	65 3/4 [1670]	43 [1092]	32 [813]	642 [291]	846 [384]	897 [407]	773 [351]
2440	24 [610]	40 [1016]	53 5/6 [1367]	78 1/4 [1988]	75 1/4 [1911]	43 [1092]	32 [813]	716 [325]	928 [421]	978 [444]	856 [388]
3240	32 [813]	40 [1016]	61 5/6 [1570]	78 1/4 [1988]	75 1/4 [1911]	43 [1092]	32 [813]	843 [382]	1067 [484]	1125 [510]	996 [452]
3255	32 [813]	55 [1397]	61 5/6 [1570]	93 1/4 [2369]	90 1/4 [2292]	43 [1092]	32 [813]	1012 [459]	1280 [581]	1342 [609]	1196 [542]
3855	38 [965]	55 [1397]	67 5/6 [1723]	93 1/4 [2369]	90 1/4 [2292]	43 [1092]	32 [813]	1090 [494]	1366 [620]	1434 [650]	1282 [582]
4455	44 [1118]	55 [1397]	73 5/6 [1875]	93 1/4 [2369]	90 1/4 [2292]	43 [1092]	32 [813]	1288 [584]	1583 [718]	1657 [752]	1500 [680]

DS Models

SINGLE OVEN	A	B	C	D	E	F	G	OVEN WEIGHT	CRATED WEIGHTS (1 CRATE)		
									DOM. WOOD	INTL. WOOD	METAL SKID
3250-DS	32 [813]	50 [1270]	61 7/8 [1572]	90 1/2 [2299]	90 1/4 [2292]	48 5/8 [1235]	35 [889]	978 1/2 [444]	1104 [501]	1185 [538]	1044 [474]

NOTE: All dimensions in inches [millimeters], ± 1/4 [6], unless otherwise noted.
All weights in pounds [kilograms] unless otherwise noted.

Double Stack

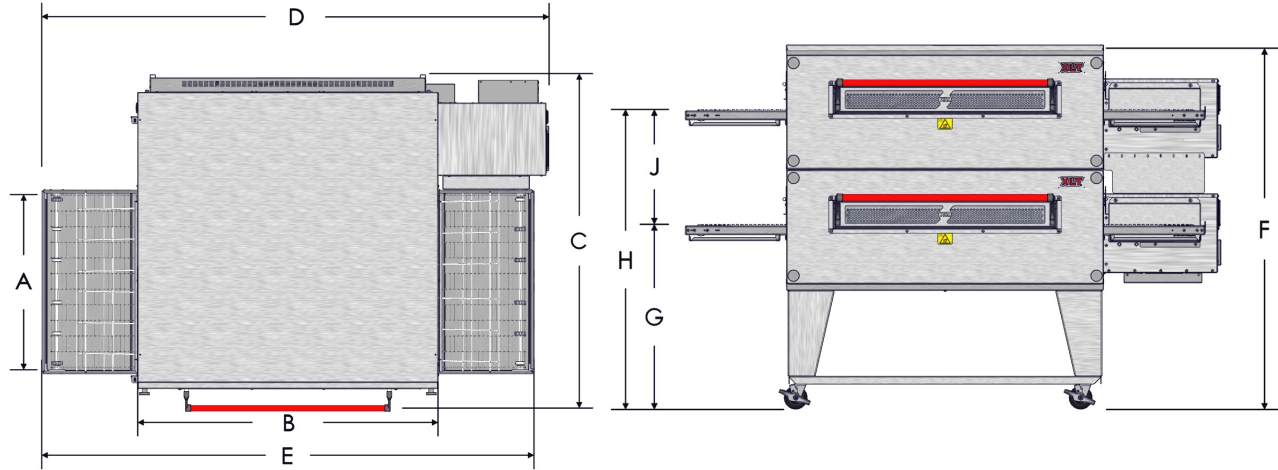

DOUBLE STACK	A	B	C	D	E	F	G	H	J	OVEN WEIGHT	DOUBLE OVEN	CRATED WEIGHTS		
												DOM. WOOD	INTL. WOOD	METAL SKID
1832	18 [457]	32 [813]	47 5/6 [1215]	70 1/4 [1784]	67 1/4 [1708]	63 [1600]	32 [813]	52 [1321]	20 [508]	1030 [467]	1832	1413 [641]	1488 [675]	1259 [571]
2336	23 [584]	36 [914]	51 [1295]	70 1/4 [1784]	65 3/4 [1670]	63 [1600]	32 [813]	52 [1321]	20 [508]	1167 [529]	2336	1564 [709]	1665 [755]	1416 [642]
2440	24 [610]	40 [1016]	53 5/6 [1367]	78 1/4 [1988]	75 1/4 [1911]	63 [1600]	32 [813]	52 [1321]	20 [508]	1304 [591]	2440	1714 [777]	1815 [823]	1571 [713]
3240	32 [813]	40 [1016]	61 5/6 [1570]	78 1/4 [1988]	75 1/4 [1911]	63 [1600]	32 [813]	52 [1321]	20 [508]	1533 [695]	3240	1966 [892]	2081 [944]	1823 [827]
3255	32 [813]	55 [1397]	61 5/6 [1570]	93 1/4 [2369]	90 1/4 [2292]	63 [1600]	32 [813]	52 [1321]	20 [508]	1840 [835]	3255	2357 [1069]	2482 [1126]	2189 [993]
3855	38 [965]	55 [1397]	67 5/6 [1723]	93 1/4 [2369]	90 1/4 [2292]	63 [1600]	32 [813]	52 [1321]	20 [508]	1981 [899]	3855	2512 [1139]	2648 [1201]	2345 [1064]
4455	44 [1118]	55 [1397]	73 5/6 [1875]	93 1/4 [2369]	90 1/4 [2292]	63 [1600]	32 [813]	52 [1321]	20 [508]	2362 [1071]	4455	2931 [1329]	3078 [1396]	2764 [1254]

DS Models

DOUBLE STACK	A	B	C	D	E	F	G	H	J	OVEN WEIGHT	DOUBLE OVEN	CRATED WEIGHTS (2 CRATES)		
												DOM. WOOD	INTL. WOOD	METAL SKID
3250-DS	32 [813]	50 [1270]	61 7/8 [1572]	77 7/8 [1978]	78 [1981]	67 3/4 [1721]	28 [711]	54 [1372]	26 [660]	1779 [807]	3250-DS	2030 [921]	2192 [994]	1910 [866]

NOTE: All dimensions in inches [millimeters], ± 1/4 [6], unless otherwise noted.
All weights in pounds [kilograms] unless otherwise noted.

Triple Stack

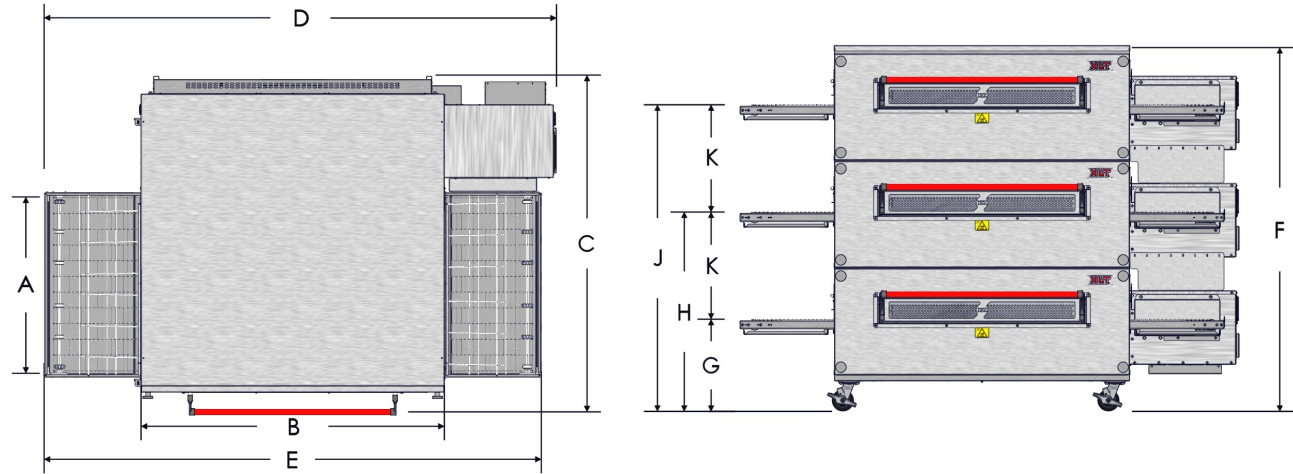

TRIPLE STACK	A	B	C	D	E	F	G	H	J	K	OVEN WEIGHT
1832	18 [457]	32 [813]	47 5/6 [1215]	70 1/4 [1784]	67 1/4 [1708]	68 [1727]	17 [432]	37 [940]	57 [1448]	20 [508]	1457 [661]
2336	23 [584]	36 [914]	51 [1295]	70 1/4 [1784]	65 3/4 [1670]	68 [1727]	17 [432]	37 [940]	57 [1448]	20 [508]	1664 [755]
2440	24 [610]	40 [1016]	53 5/6 [1367]	78 1/4 [1988]	75 1/4 [1911]	68 [1727]	17 [432]	37 [940]	57 [1448]	20 [508]	1855 [841]
3240	32 [813]	40 [1016]	61 5/6 [1570]	78 1/4 [1988]	75 1/4 [1911]	68 [1727]	17 [432]	37 [940]	57 [1448]	20 [508]	2185 [991]
3255	32 [813]	55 [1397]	61 5/6 [1570]	93 1/4 [2369]	90 1/4 [2292]	68 [1727]	17 [432]	37 [940]	57 [1448]	20 [508]	2629 [1192]
3855	38 [965]	55 [1397]	67 5/6 [1723]	93 1/4 [2369]	90 1/4 [2292]	68 [1727]	17 [432]	37 [940]	57 [1448]	20 [508]	2830 [1284]
4455	44 [1118]	55 [1397]	73 5/6 [1875]	93 1/4 [2369]	90 1/4 [2292]	68 [1727]	17 [432]	37 [940]	57 [1448]	20 [508]	3393 [1539]

TRIPLE OVEN	CRATED WEIGHTS		
	DOM. WOOD	INTL. WOOD	METAL SKID
1832	2022 [917]	2134 [968]	1791 [812]
2336	2250 [1021]	2402 [1090]	2029 [920]
2440	2460 [1116]	2612 [1185]	2246 [1019]
3240	2823 [1280]	2995 [1359]	2609 [1183]
3255	3391 [1538]	3579 [1623]	3140 [1424]
3855	3612 [1638]	3816 [1731]	3361 [1525]
4455	4231 [1919]	4452 [2019]	3980 [1805]

NOTE: All dimensions in inches [millimeters], ± 1/4 [6], unless otherwise noted.
All weights in pounds [kilograms] unless otherwise noted.

Electric Oven Electrical Requirements											
Per EACH Oven											
Oven Model	STANDARD					WORLD					
	Volts AC	Amps	Hertz	Phase	KW	Volts AC	Amps	Hertz	Phase	KW	
1832	208	45	60	3	16	380	31	50	3	16	
	240	39				415	24			15	
2336	208	45				380	31			16	
	240	39				415	24			15	
2440	208	82				380	51			27	
	240	65				415	44			31	
3240	208	82			380	51	27				
	240	65			415	44	31				
3250-DS	208	90			32	380	55			32	
	240	80				415	48			34	
3255	208	90				380	55			32	
	240	80				415	48			34	
3855	208	90	380	55		32					
	240	80	415	48		34					
4455	208	90	380	55		32					
	240	80	415	48		34					
4 Wire Service - L1, L2, L3 +1 Ground (per oven)						5 Wire Service - L1, L2, L3 N +2 Grounds (per oven)					

FOR EACH OVEN:

- A separate circuit breaker must be provided for each oven deck.
- Electrical connections must be accessible when the ovens are in the installed position.
- Electrical connections must meet all local code requirements.
- Ensure ovens are grounded per local codes.

Control Box Rear - Standard

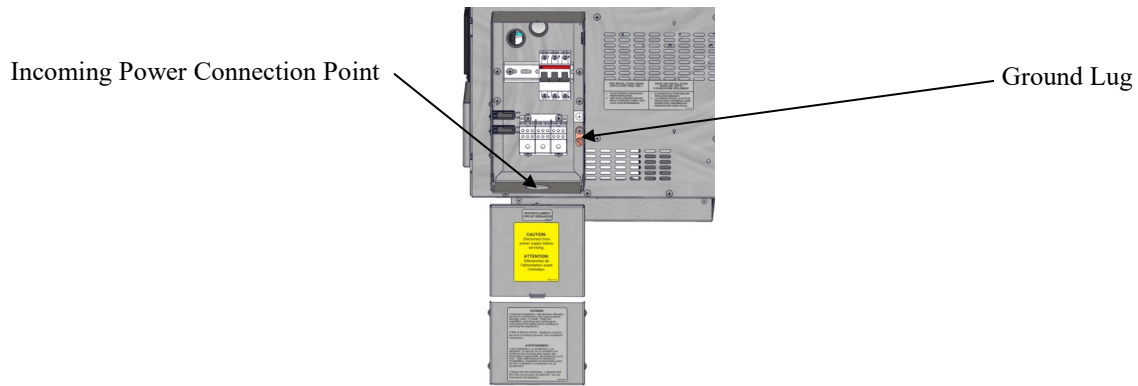

Control Box Rear - World

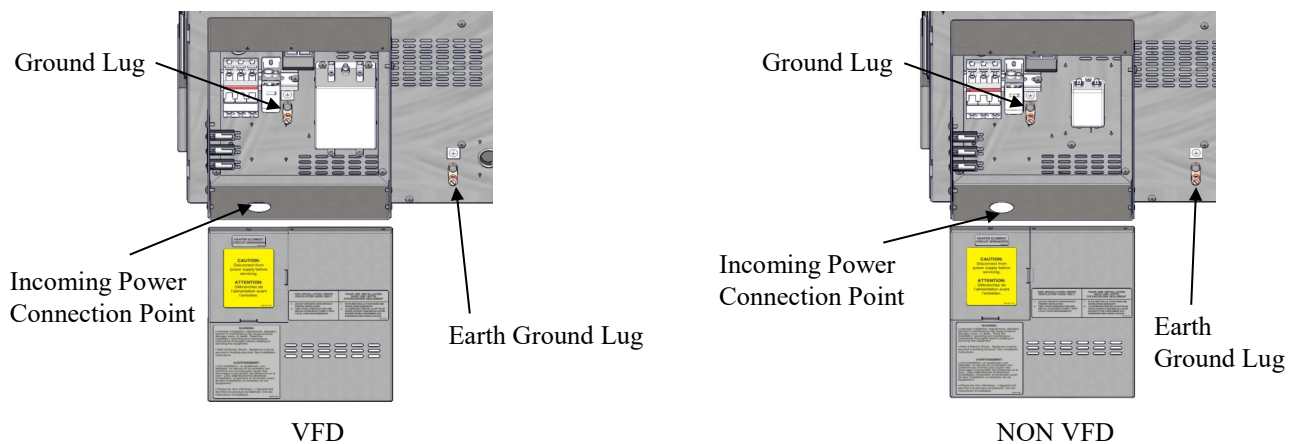

1832, 2336 and 2440 Models

These ovens are suitable for installation on either combustible or non-combustible floors, and adjacent to either combustible or non-combustible walls. The motor cover is designed to provide the proper clearance to the back of the oven. The minimum side clearances are 6in./150mm, measured from the ends of the conveyor.

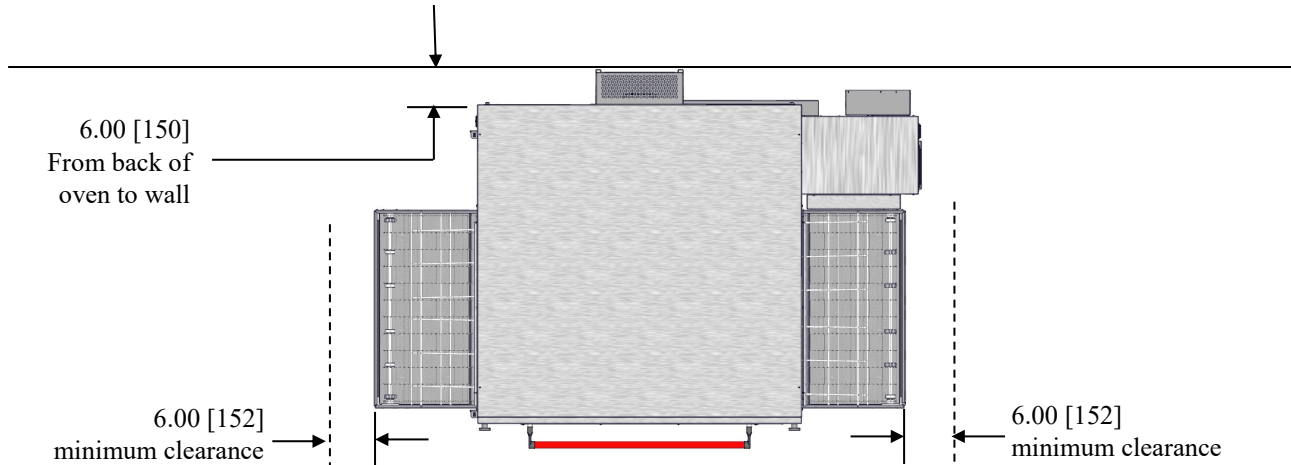

All Other Models

These ovens are suitable for installation on either combustible or non-combustible floors, and adjacent to either combustible or non-combustible walls. The motor cover is designed to provide the proper clearance to the back of the oven. The minimum side clearances are 6in./152mm measured from the ends of the conveyor.

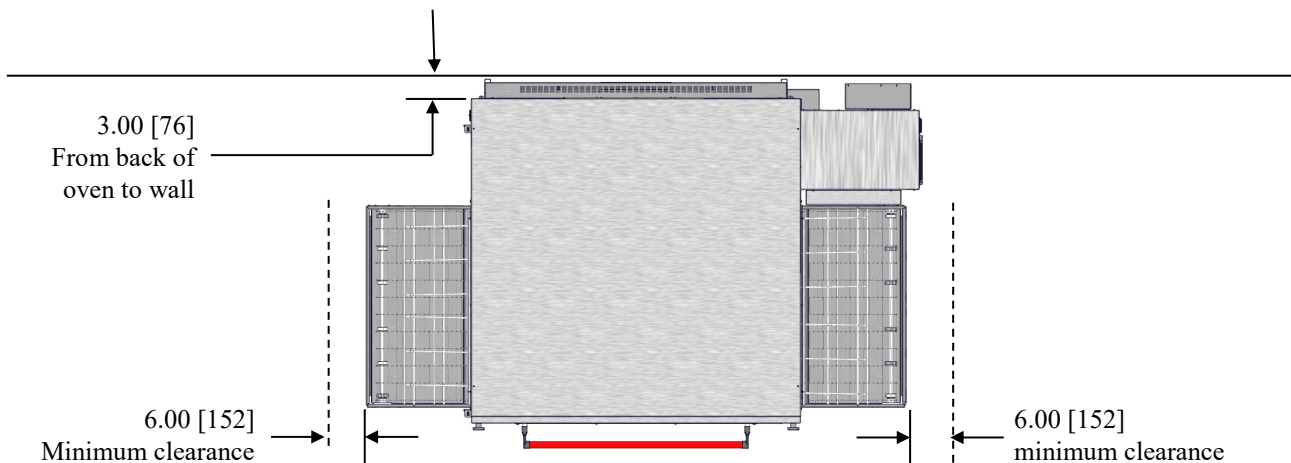

NOTE

All installations must conform to local building and mechanical codes. It is required that the ovens be placed under a ventilation hood to provide exhaust ventilation and adequate air supply.



NOTE

Equipment must be installed with cord anchorage to relieve strain on conductors, twisting of terminals, and abrasions to insulation.

NOTE: All dimensions in inches [millimeters], $\pm 1/4$ [6], unless otherwise noted.

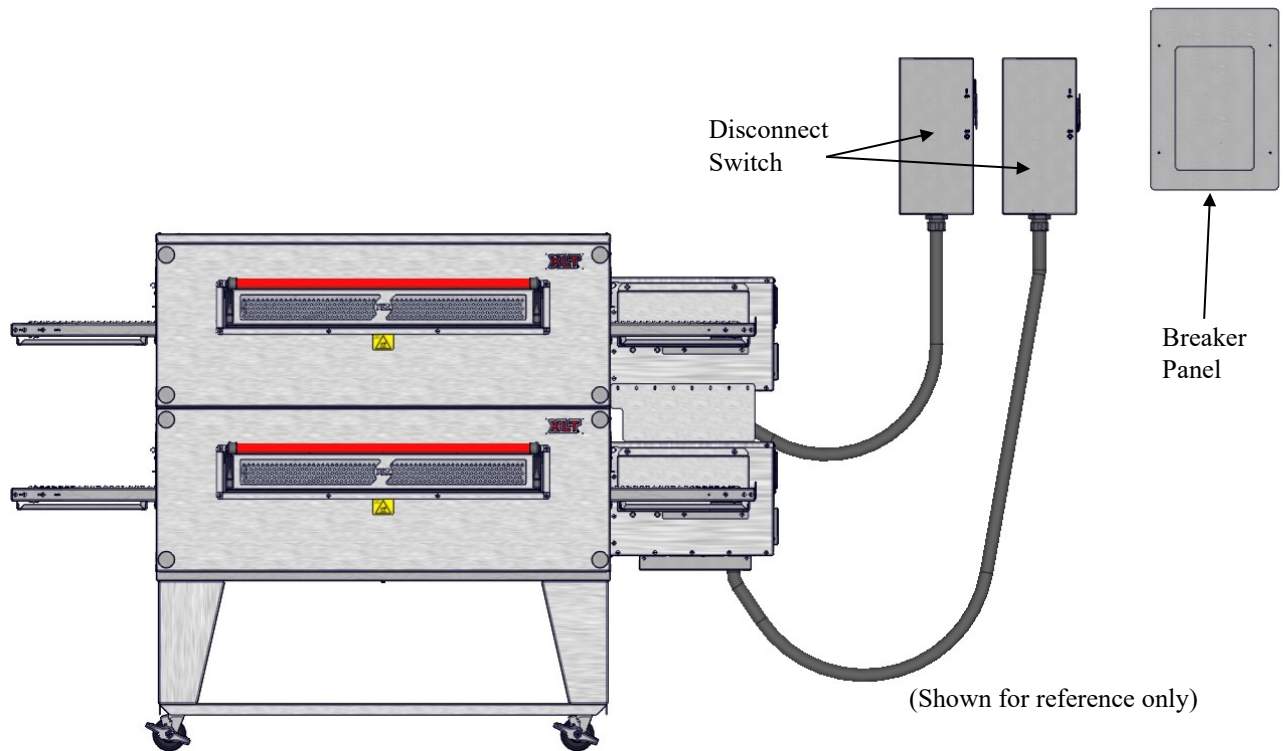

CAUTION

Utilities must be easily accessible when the ovens are in the installed position. Do not install utilities behind the ovens.



NOTE

All installations must conform to local building and mechanical codes. It is required that the ovens be placed under a ventilation hood to provide exhaust ventilation and adequate air supply.



NOTE

Equipment must be installed with cord anchorage to relieve strain on conductors, twisting of terminals, and abrasions to insulation.

Warning & Safety Information

XLT ovens can easily be moved and stacked with the proper lifting equipment. The use of XLT approved lifting equipment is highly recommended. Contact XLT for more information.



DANGER

- These ovens are heavy and can tip or fall causing bodily injury.
- NEVER place any part of your body beneath any oven that is suspended by the lifting jacks. A crush hazard exists if the oven falls or slips.
- DO NOT place your hands on the lifting jack vertical pole beneath the jack's winch. As the jack's winch descends when you turn the jack handle, a pinch point is created between the winch and the pole.



CAUTION

BE CAREFUL when rolling the oven on the cart, especially when going up or down ramps and over bumps. Leave the straps/banding on until the oven is near the assembly area.



DANGER

- Make sure that the notch on tube of the winch assembly is aligned with the pin in the tripod base as shown on next view pages. These alignments are important and keep the jack aligned properly.
- Check for smooth operation. The cable should not be pinched and should pass smoothly over the pulley on top of the pole assembly.
- Inspect cable prior to each use.
- If cable is frayed or shows signs of excessive wear and tear, DO NOT USE until cable is replaced.
- At a minimum replace the cable annually with wire rope that meets or exceeds the jack manufacturer's specifications.
- Do not exceed the stated capacity of the jack.

Base Assembly - Single and Double Stack

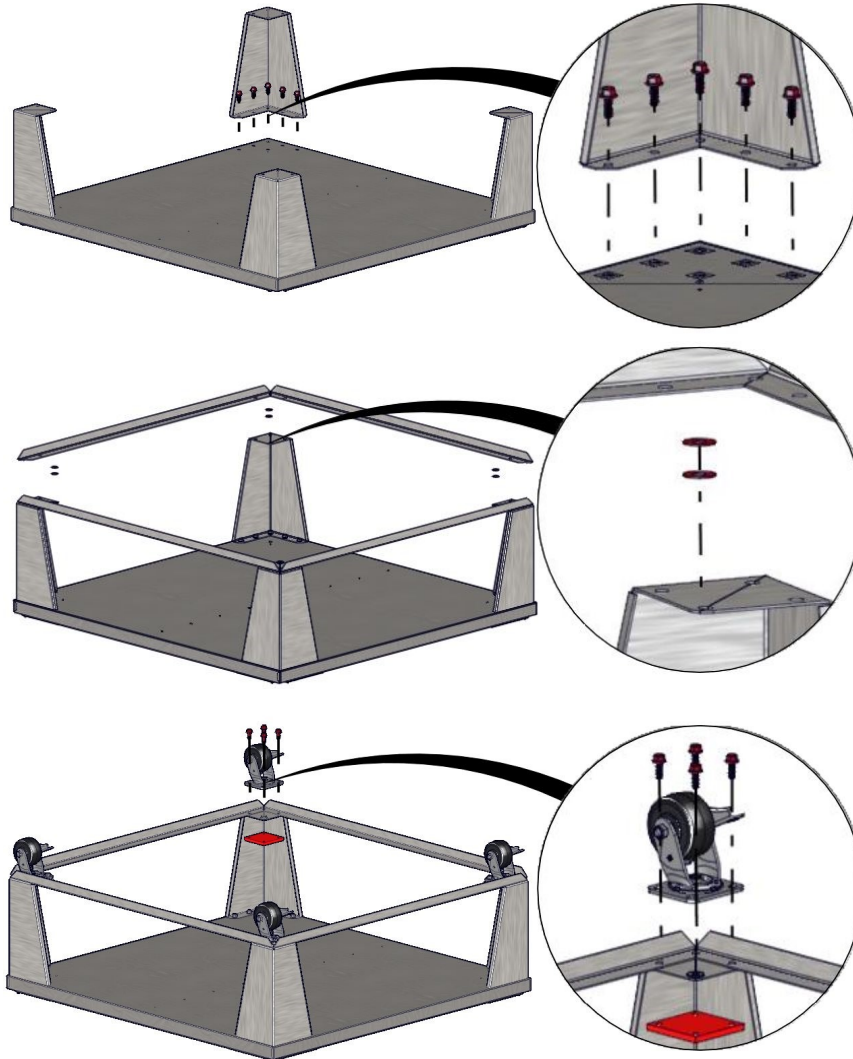

Base Assembly - Triple Stack

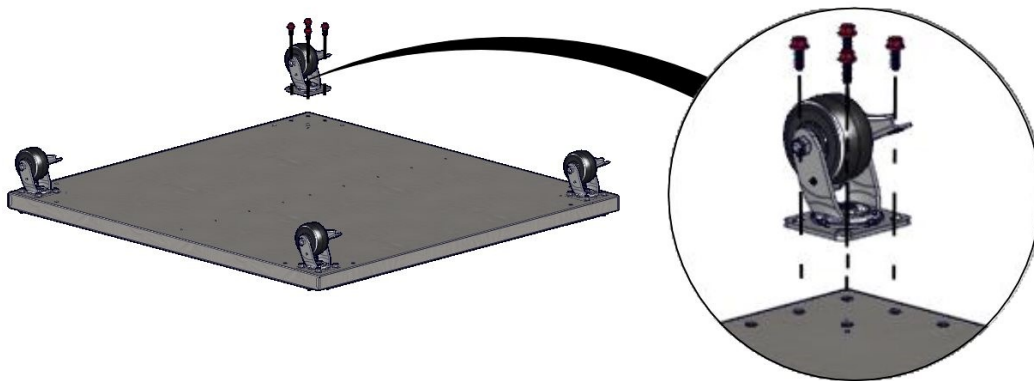



TIP

Review and understand the next eight (8) steps first. They illustrate how to stack the ovens safely.

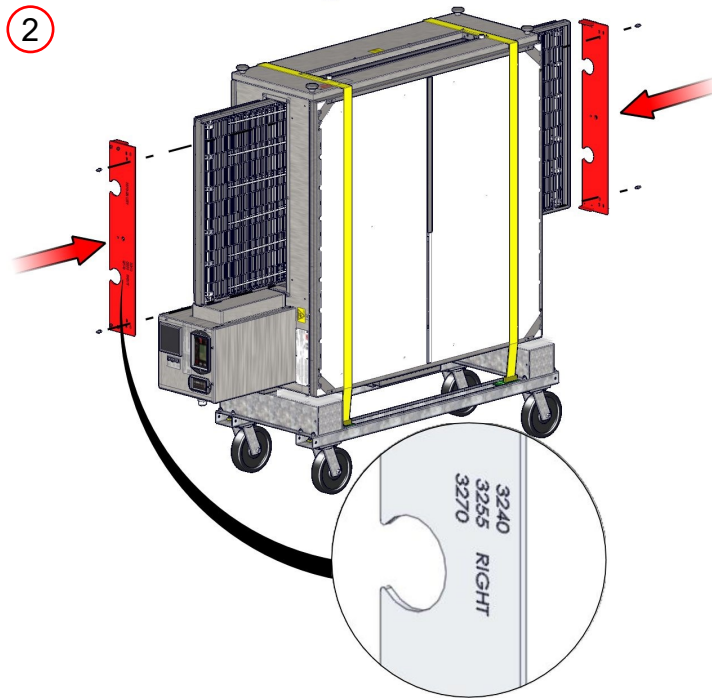
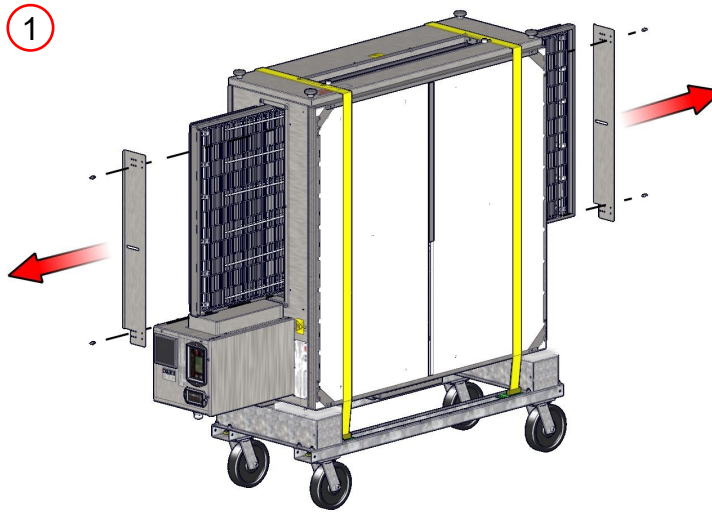

NOTE

The Lifting Pipe hole, marked for the appropriate oven size, must be installed closest to the control box. If your lifting plates do not have all of our available sizes listed follow the table below.

Oven Size	Lifting Plate Position
3250	3270-2B
3265	3270-2B
3280	3270-2B
3880	3870-2B

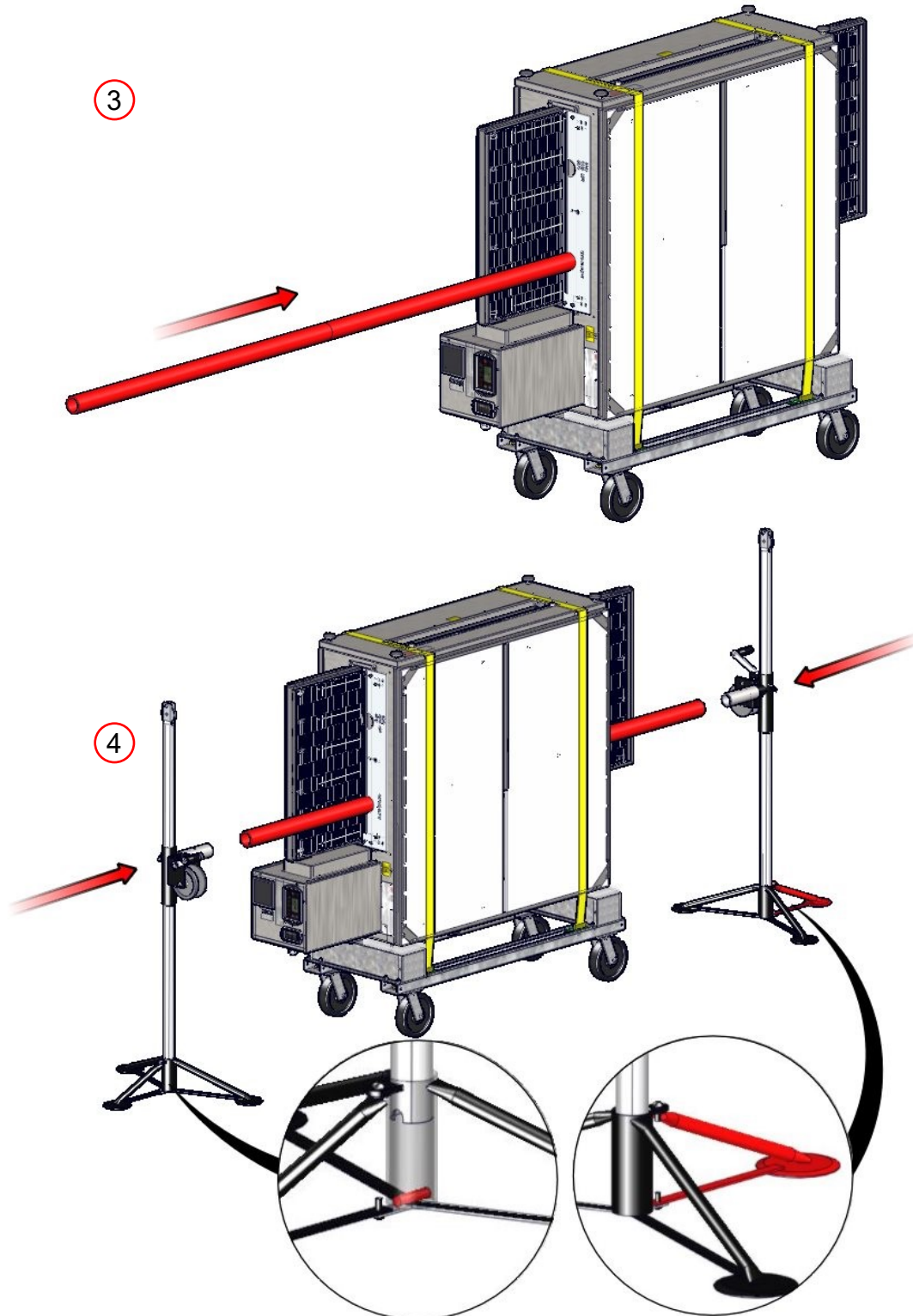

The folding leg of the tripod must be positioned outward from the oven.

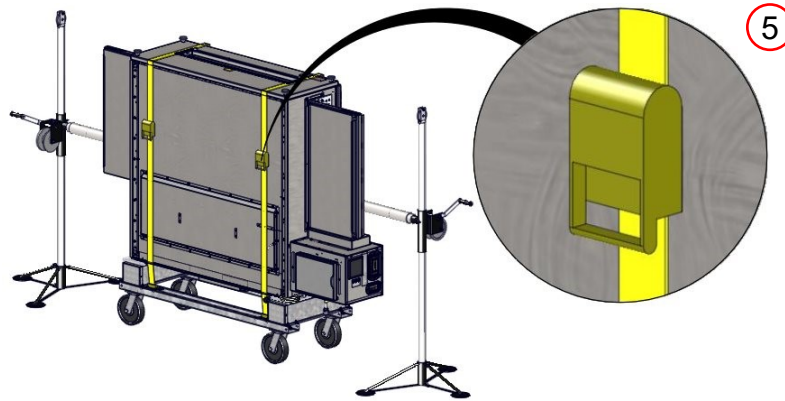

NOTE

Use the release tab on the strap to loosen and remove both straps.

Stacking the Ovens



DANGER

Failure to engage the Lifting Jacks into the Lifting Pipe properly and completely will result in damage, injury, or death from a falling oven.



DANGER

- Both jacks should be raised in unison, otherwise they may bind and a dangerous situation will develop.
- Do not put any part of yourself under the oven at any time.
- The oven is top heavy. Be careful.

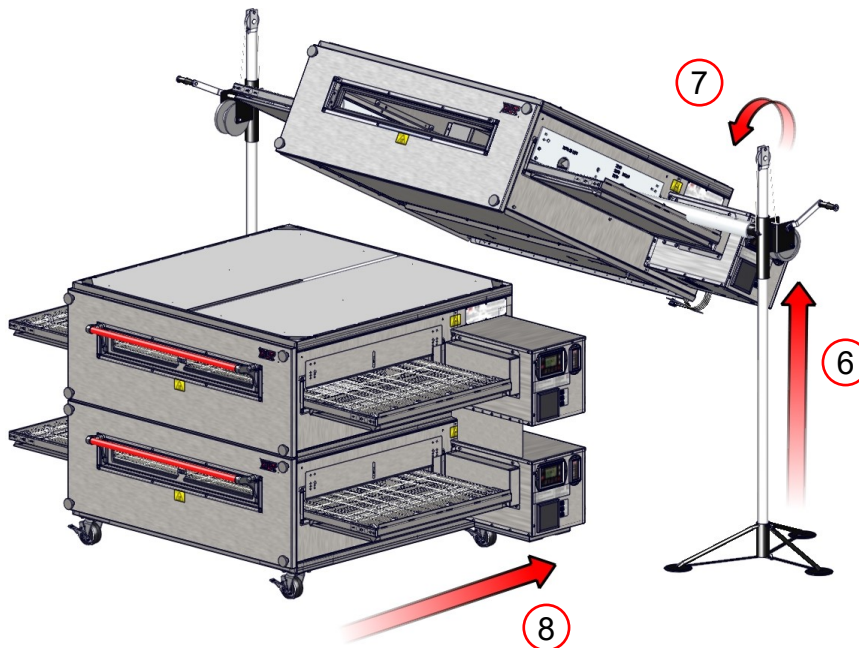

NOTE

DS model ovens can only be used in single or double oven stack configurations only.



Individuals with pacemakers or internal medical devices should not handle strong rare-earth magnets. These magnets are found in the sandwich door assembly.

Removing Finger Clips

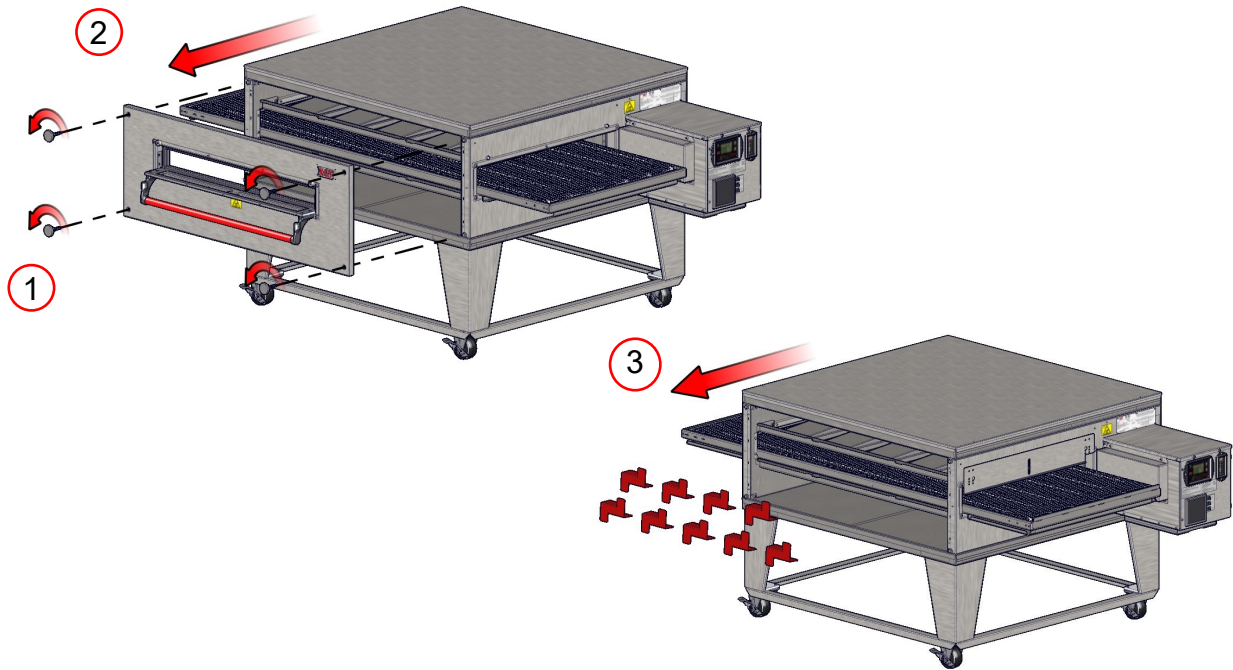

All DS model front panels will have lifting handles.

Finger clips for transportation purposes only. Discard once removed.

Installing Sandwich Door

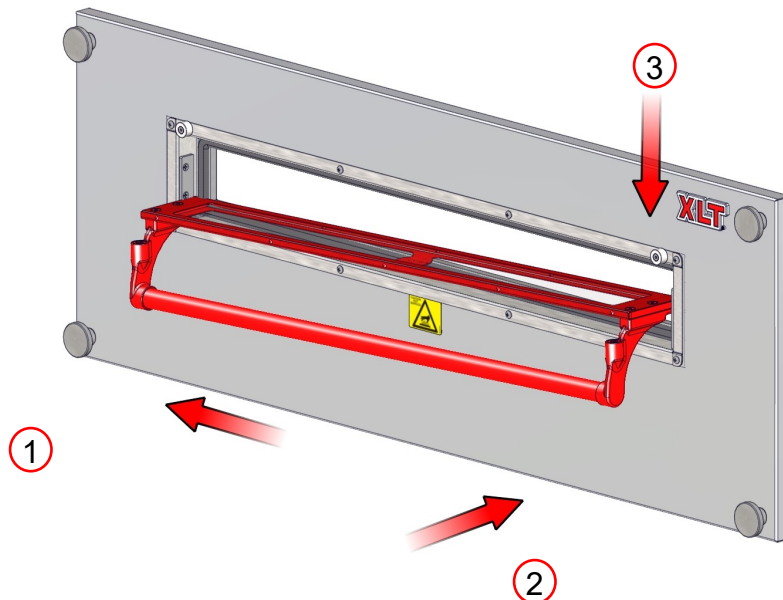

Installing Accessories

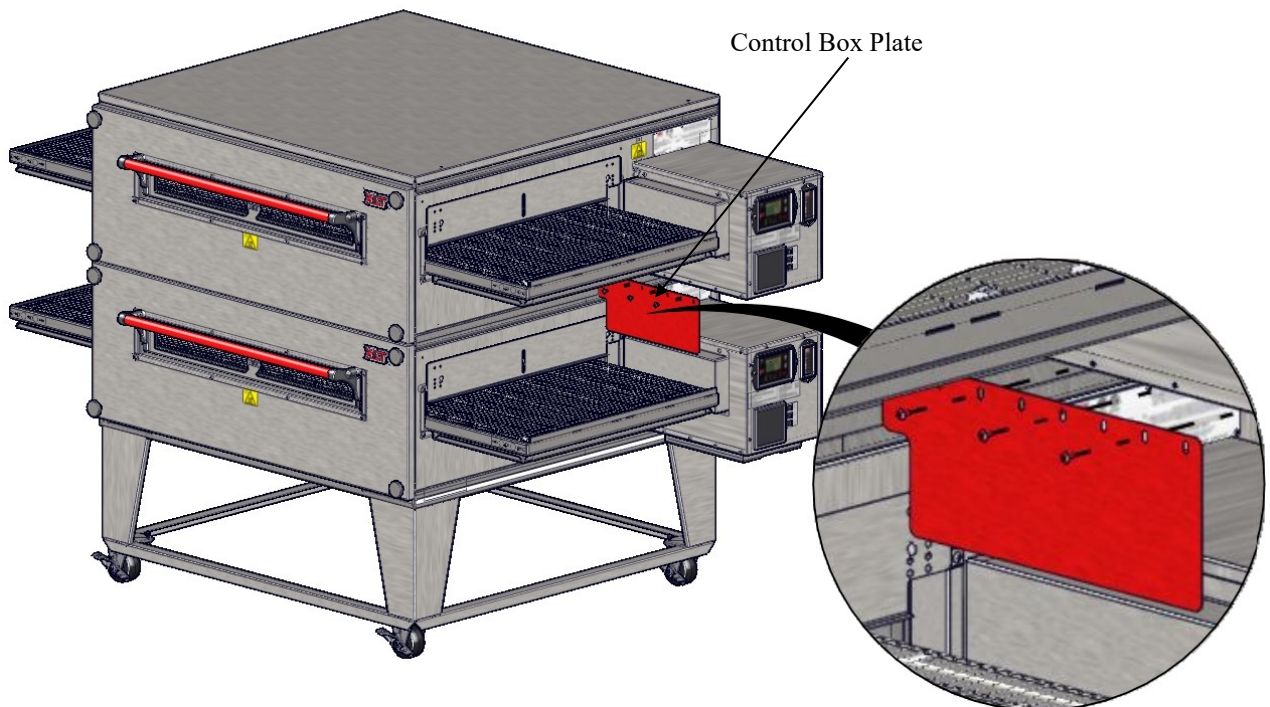
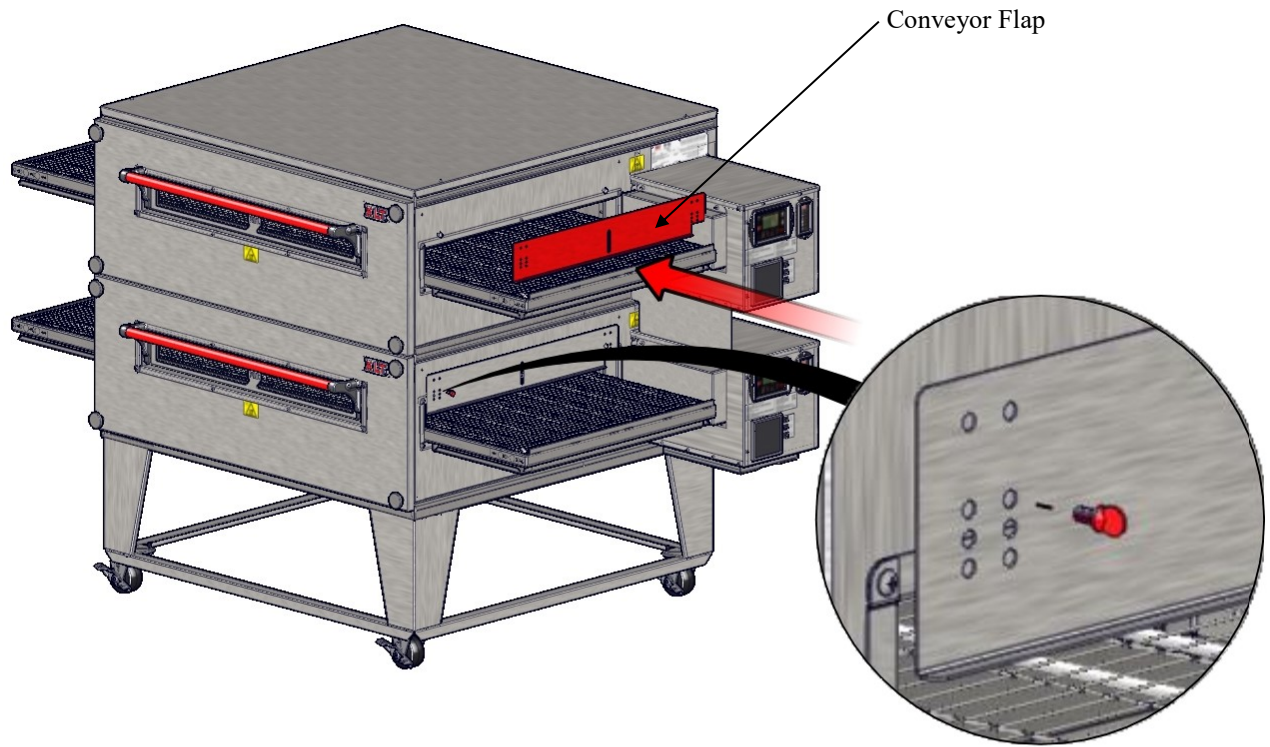

Physical Location and Spacing Requirements

These ovens are suitable for installation on either combustible or non-combustible floors, and adjacent to either combustible or non-combustible walls. The motor cover is designed to provide the proper clearance to the back of the oven. The minimum side clearances are 6in. / 150mm, measured from the end of the conveyor.



All installations must conform to local building and mechanical codes.

NOTE

Restraint

Because all ovens are equipped with casters, all installations must be configured with a restraint to limit the movement of the oven without depending on the electric power supply cord to limit the oven movement. One (1) restraint kit, which includes one (1) eye bolt, one (1) stainless steel clip and a cable, is required for each oven stack, regardless if used on a single, double, triple or quad configuration. The clip should be installed in the lowest hole of the back wall on the control end of the lowest oven in the stack. The lag eye bolt must be installed into a structural member of a wall or the floor. It is the owner's responsibility to ensure the restraint is installed correctly.

Upon completion of performing any service or cleaning functions that require removal of the restraint, insure that it is correctly re-attached to the oven.

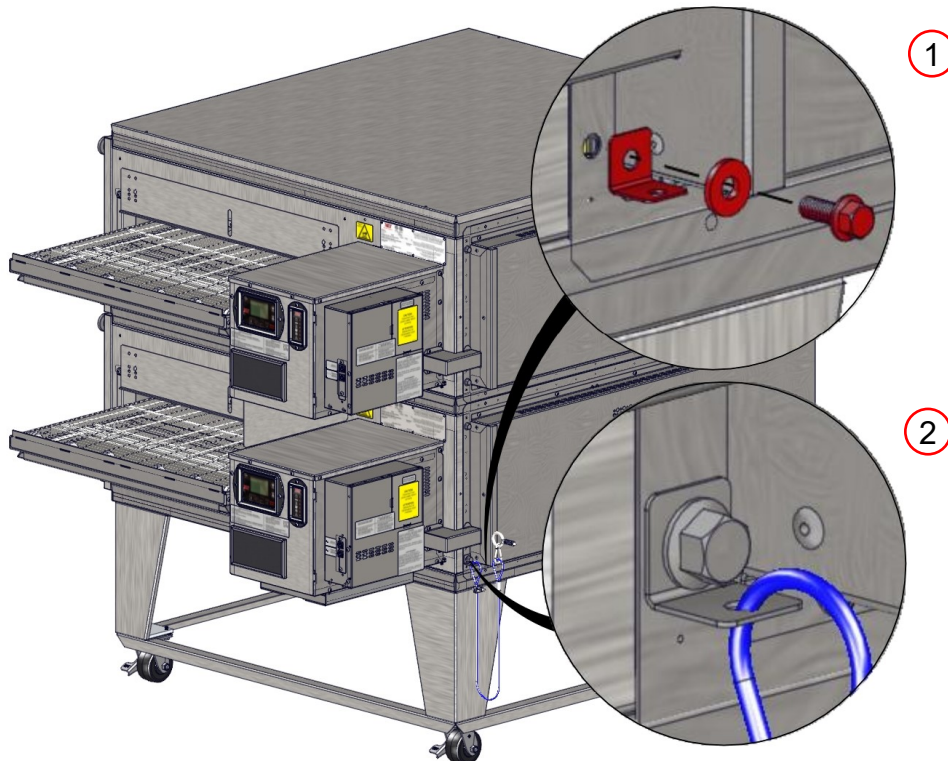

The requirement for fire suppression systems vary by location and the authority having jurisdiction. If you are required to install fire suppression on your oven, a pre-assembled piping kit is available that utilizes pre-existing holes to simplify installation and future service.

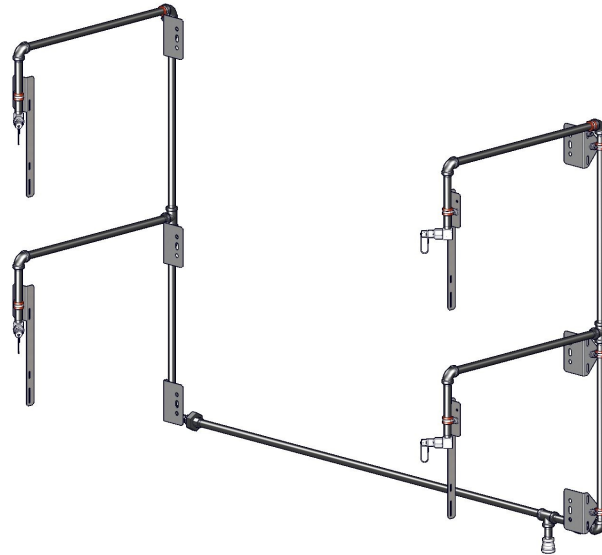

This design has been tested and approved to successfully comply with fire suppression codes. It uses only two (2) nozzles per bake chamber, and allows crumb trays, chain guards, and all other accessories to be easily removed. The kit does not interfere with any operations or maintenance.

For detailed information regarding fire suppression, see manual XD-9011 Fire Suppression Installation for XLT Hoods and XLT Ovens.

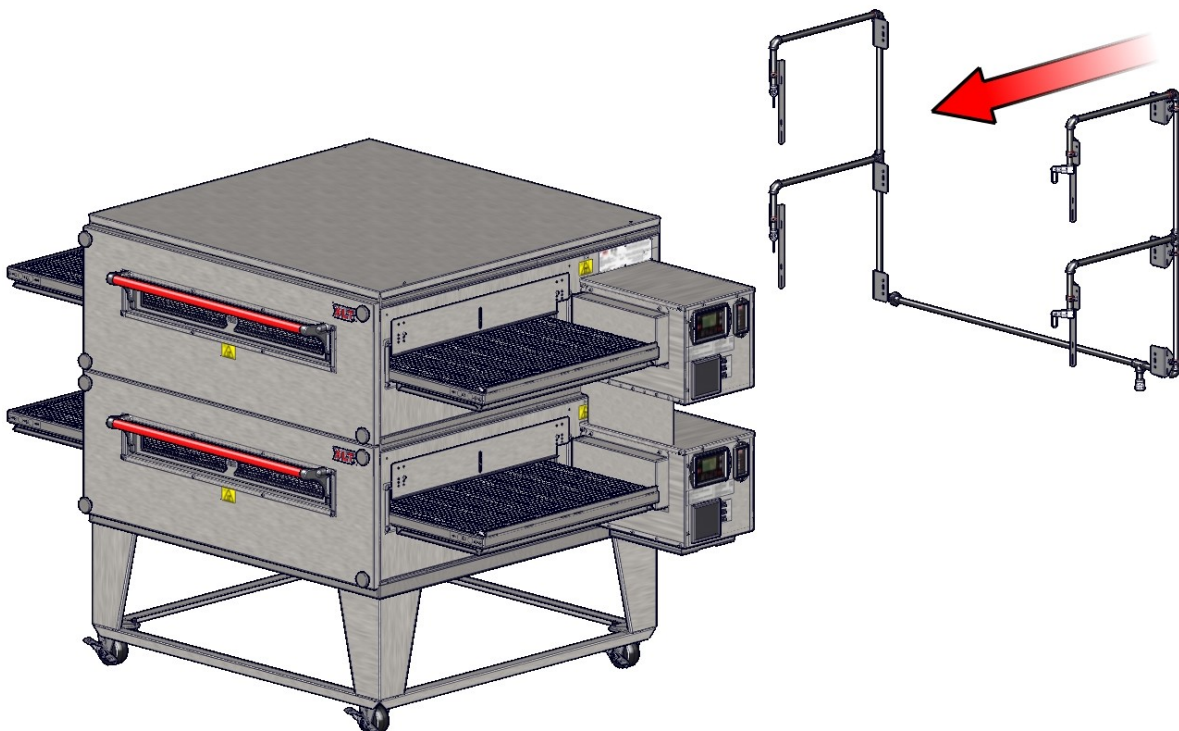

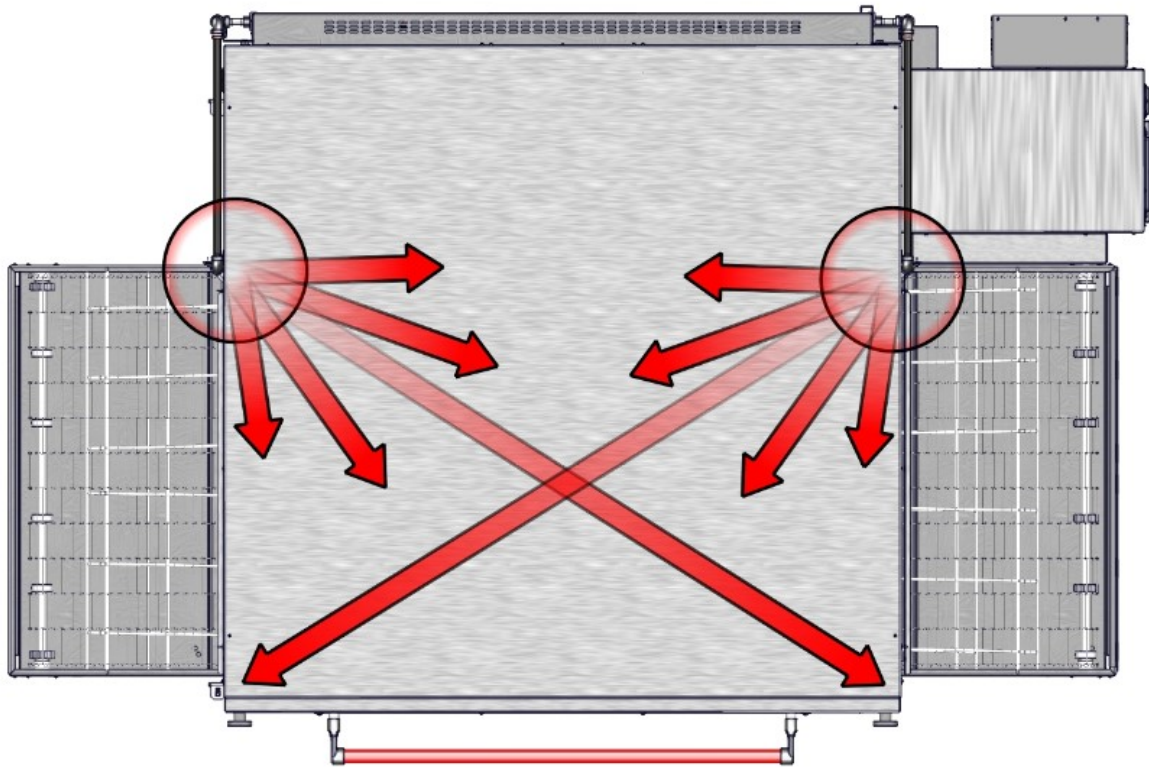
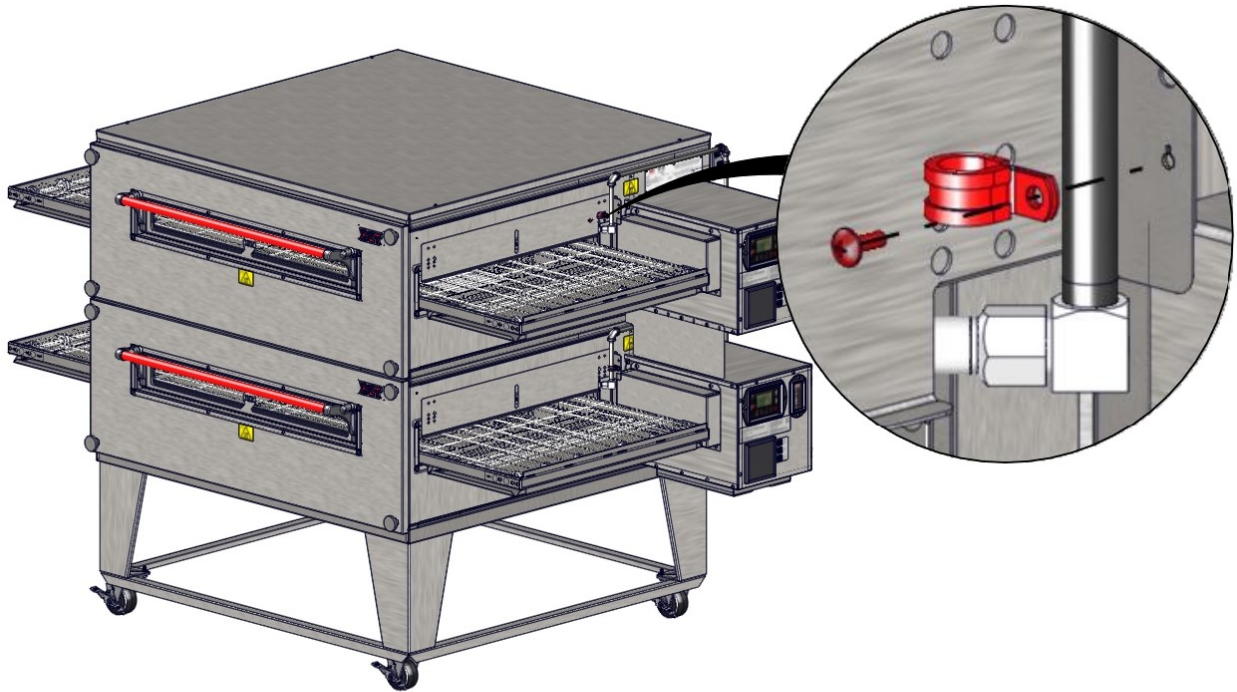

Ventilation Requirements

A powered ventilation hood is required to remove heat and vapors. Some provision must be made to replenish the amount of air that is extracted from the building. The hood and HVAC installation must meet local building and mechanical codes. Requirements vary throughout the country depending upon location. Proper ventilation is the oven owner's responsibility. The XLT hood system is designed to meet all requirements for XLT ovens and it is our recommendation that this system be used.

Ventilation Guidelines

Obtain information from the authority having jurisdiction to determine the requirements for your installation. Your ventilation hood supplier and HVAC contractor should be contacted to provide guidance. An air balance test is highly recommended and should be performed by a licensed contractor. A properly engineered and installed ventilation hood and HVAC system will expedite approval, reduce all maintenance costs, and provide a more comfortable working environment. XLT also recommends that the operator controls for the ovens and the operator control for the exhaust fan be interlocked so that the exhaust fan gets energized whenever the ovens are turned on.

Ventilation Performance Test

After the oven and ventilation hood have been installed and are operating, a smoke candle can be used to "see" if the heat and vapors are being completely extracted. The test procedure is outlined below:

1. The oven must be operating at user defined temperature, or the oven must be operating at 450-500F/232-260C.
2. The conveyor must be turned off.
3. The ventilation hood exhaust fan must be turned on.
4. Put a smoke candle in a pan on the conveyor belt at the center of the oven.
5. Observe the smoke pattern coming out of the oven.
6. Repeat the smoke candle test for each oven, as well as when all ovens are operating.

The ventilation hood must capture all of the smoke from the oven.

After the exhaust fan has been adjusted to completely capture and contain the heat, there needs to be a corresponding amount of make up air (MUA) introduced into the building to offset the amount of air volume being removed. An air balance test can determine the proper amount of make-up air flow rates.

All ovens are tested at the factory for functional operation. Operation is verified and adjustments are made to ensure proper function. However, field conditions are sometimes different than factory conditions. **It is necessary to have an authorized service technician verify operation and make field adjustments if needed.**

The Oven Initial Start-Up Checklist, found at the end of this manual, must be completed at time of installation, signed by the Customer and returned to XLT and the Authorized Distributor to initiate Warranty Policy. **If the Start-Up Checklist is not filled out completely and returned to XLT the warranty will not be honored.**

Start-up Procedure

1. Ensure that all ovens have been installed in accordance with the Installation and Operation Manual, and all utilities are connected to the ovens in compliance with local building codes.
2. Complete Start-up checklist with owner signature and return to XLT.



CAUTION

Do Not Exceed 65 Hz On VFD Settings.



NOTE

All XLT ovens will come programmed for a bake time of 5:00 minutes and a temperature of 500°F/260°C. End users are responsible for determining oven settings. The tables below indicate minimum and maximum values for bake time and temperature.

Conveyor Belt Times (Min:Sec)		
Oven Models	MINIMUM	MAXIMUM
1832	1:30	17:00
xx36-xx55	1:30	20:00

Oven Operating Temperature Range		
Oven Models	MINIMUM	MAXIMUM
All	300° F	590° F
	149° C	310° C



This oven is not capable of being safely placed in operation in the event of a power failure. No attempt should be made to operate this oven during power failure.

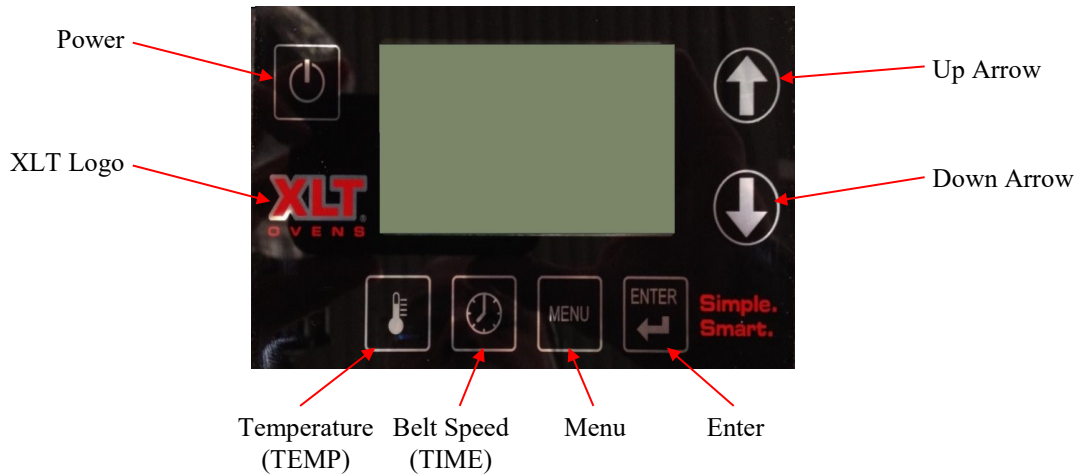

- 1 **Turn On:** Hold the Power Button for one (1) second. Press the Enter button to confirm oven start up.

Temperature Adjustment



- 2 **Temperature Adjust:** Press TEMP button for three (3) seconds. To adjust temperature use either the Up or Down arrow. If double burner press the TEMP button to toggle between burner temps. Press Enter to save.

Belt Time Adjustment



- 3 **Belt Time Adjust:** Press TIME button for three (3) seconds. To adjust belt time use either the Up or Down arrow. If split belt, press the TIME button to toggle between belt times. Press Enter to save.

- 4 **Turn Off:** Hold the Power Button for one (1) second.

Menu Mode (Optional)



The Menu programming can store up to twelve (12) preset menus that can be recalled by number as needed. Each program contains a specified baking temperature and belt time.

To Select A Menu Program

1. Enter Menu mode by pressing MENU for one (1) second. The number in the lower right hand corner will begin flashing.
2. Use the Up and Down arrows to scroll through the numbered menu programs.
3. To select a desired menu program press Enter for one (1) second. A black box will appear around the number (refer to above image) and will be present on the operating screen.
4. Displays will auto-exit programming screens after five (5) seconds of no activity.

To Cancel A Menu Program

1. Enter Menu mode by pressing MENU for one (1) second. The number in the lower right hand corner will begin flashing.
2. Press MENU for one (1) second again. The operating screen will return without a programmed menu in use and without a number in the lower right hand corner of the screen.

To Change Menu Setting

1. To change a setting, when the number is flashing go to desired preset and press ENTER and MENU for three (3) seconds.
2. TEMP will start flashing. Use Up/Down arrows to select temp then press ENTER.
3. TIME will start flashing. Use Up/Down arrows to select time then press and hold ENTER and MENU for three (3) seconds to save preset.

Additional User Options

Lock Settings

1. To lock and unlock oven time and temperature press TIME and ENTER for three (3) seconds till the LUI beeps once.
2. Then press TEMP, TIME, then TEMP individually within three (3) seconds to lock settings.
3. A lock or unlock symbol will show up in the lower left corner of the LUI.

Fahrenheit To Celsius

1. To change temperature from Fahrenheit to Celsius press and hold TEMP and ENTER for three (3) seconds and the settings will change.

Oven Machine Control LED's Status:

Oven Machine Control

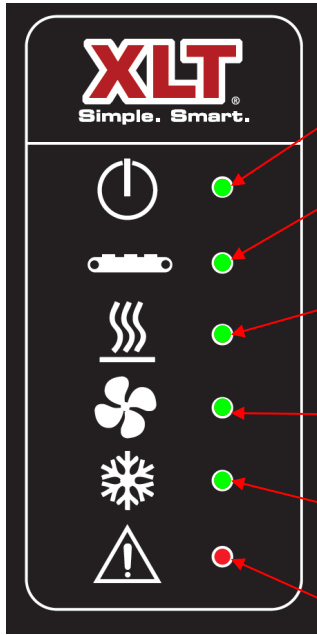

(All LEDs on for reference)

Power Green



Steady: Oven has power.

Conveyor Green



Steady: Conveyors are active.

Flash: Problem is detected.



Heat Green

Steady: Oven is calling for heat. Will remain lit while climbing to temperature.

Flash: Problem is detected.

Main Fan Green



Steady: Fan is spinning.

Flash: Problem is detected.

Cool Down Green



Steady: Oven is in cool down mode.

Alarm Red



Steady: Alarm is tripped.

Flash: Some failure conditions will cause a flashing LED.

Split Belt Conveyor Time Controls

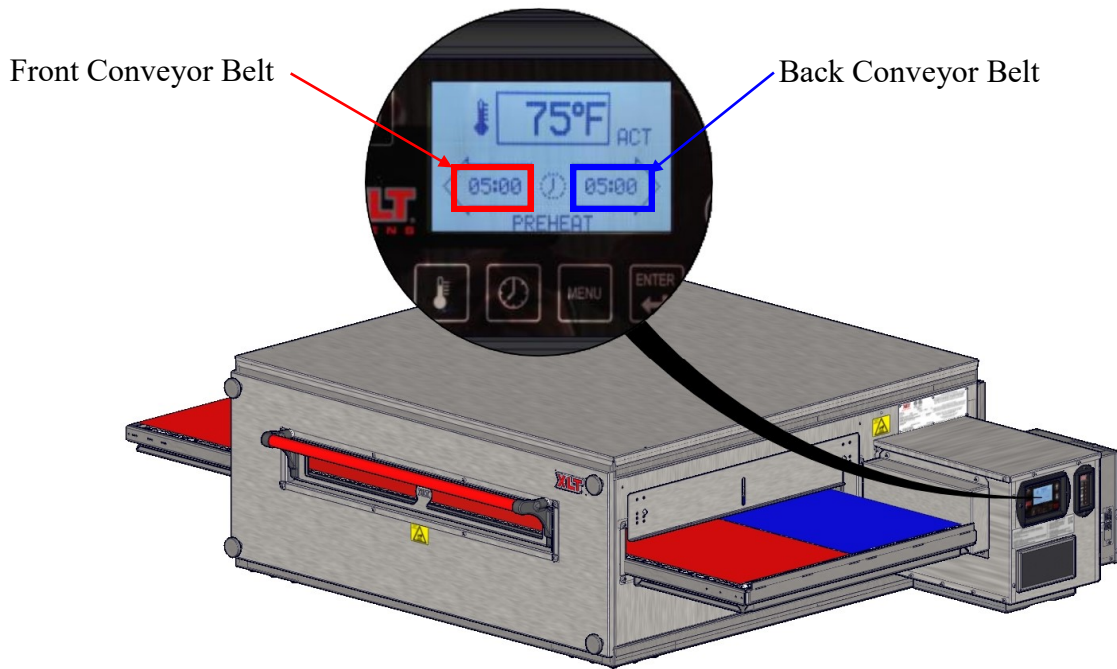

To maintain optimal bake, new fingers may be needed if belt direction is changed.



If Standard belt, only one (1) conveyor time will be displayed (refer to image below).

Standard Belt Conveyor Time Control

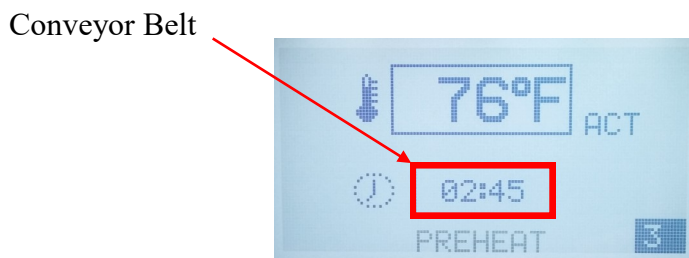

Your XLT oven is constructed of stainless steel. Most commercial cleaning agents may be used safely on all stainless steel surfaces. Check application restrictions on product label prior to usage. Observe recommended precautionary and safety measures as dictated by the product manufacturer. Bleach can cause stainless steel to discolor and corrode and is not recommended for cleaning.

Do not use caustic cleaners on the conveyor bearings as they will cause irreversible damage to the part.

Do not use abrasive cleaners or abrasive pads as they can scratch stainless steel surfaces. Areas with heavy buildup should be sprayed and allowed to soak for up to five (5) minutes prior to wiping clean. Always wipe with the “grain” of the surface to maintain appearance.

Do not use caustic cleaners on the control panel and/or electronic components. Only use cleaners compatible with Lexan® on the face of the conveyor control.

The most critical item to be cleaned is the filter on the fan. The filter is held in place by the stainless steel fan guard/filter mount and can be washed several times. Regular cleaning of the filter is important to maintain air circulation within the control box. This filter should be cleaned daily to maintain optimal air flow to the control box. Please contact XLT for replacement parts.

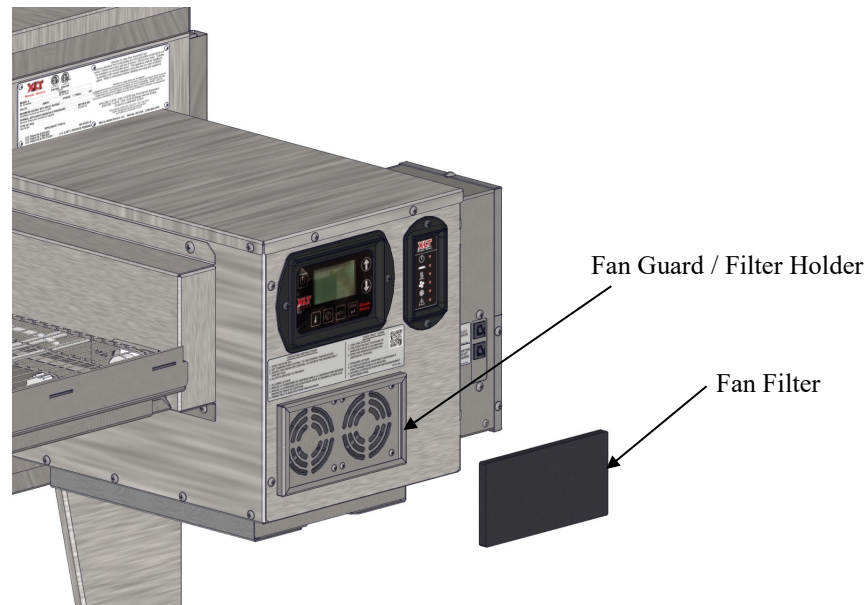

Fan Filter Maintenance

1. When fan filters need to be cleaned, an alarm will appear on the LUI saying “FILTER”.
2. Clean the fan filter.
3. Press the MENU button to enter the “FILTER RESET” screen.
4. Press ENTER to reset the filter timer. This will take you to another screen which will show you the timer back at 00:00 and will exit after five (5) seconds.



DANGER

Oven must be cool and the electric cord unplugged before any cleaning or maintenance is done.



CAUTION

If the oven is to be removed from its installed location for cleaning or servicing, the following procedure is to be followed:

1. Shut off main electrical disconnect.
2. Unplug electric cord, if equipped.
3. Unlock casters.
4. Disconnect restraint.
5. Disconnect hood relocations cord (if applicable).
6. When servicing or cleaning is complete, move oven to original location.
7. Connect hood relocations cord (if applicable).
8. Connect restraint.
9. Lock casters.
10. Plug in electric cord, if equipped.
11. Turn on main electrical disconnect.
12. Follow normal starting instructions.



TIP

Read and understand the next thirteen (13) steps first.. They illustrate how to remove components from the oven for cleaning.

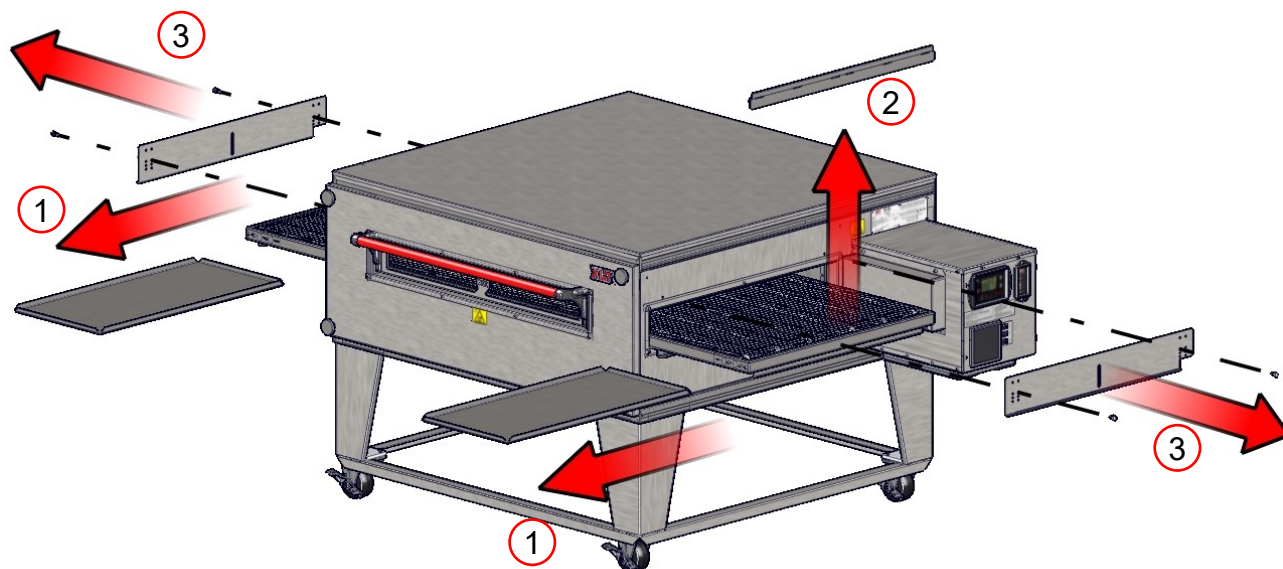



Opening the Sandwich Door will provide a grip location for removing the Front Panel.



CAUTION

Front Panels can weigh up to 66 lbs. [30 kg]. Use caution when lifting.



WARNING

Individuals with pacemakers or internal medical devices should not handle strong rare-earth magnets. These magnets are found in the sandwich door assembly.

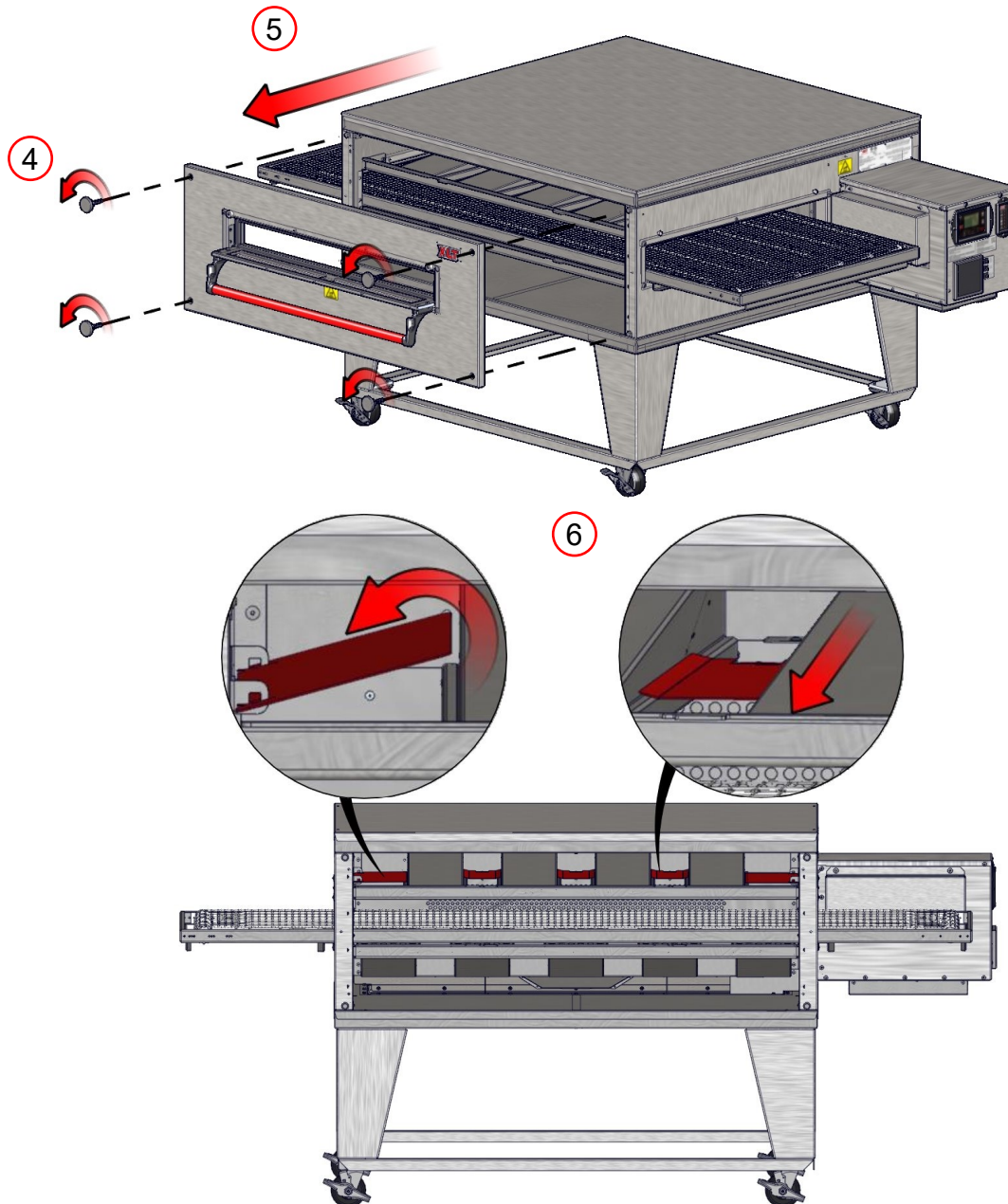

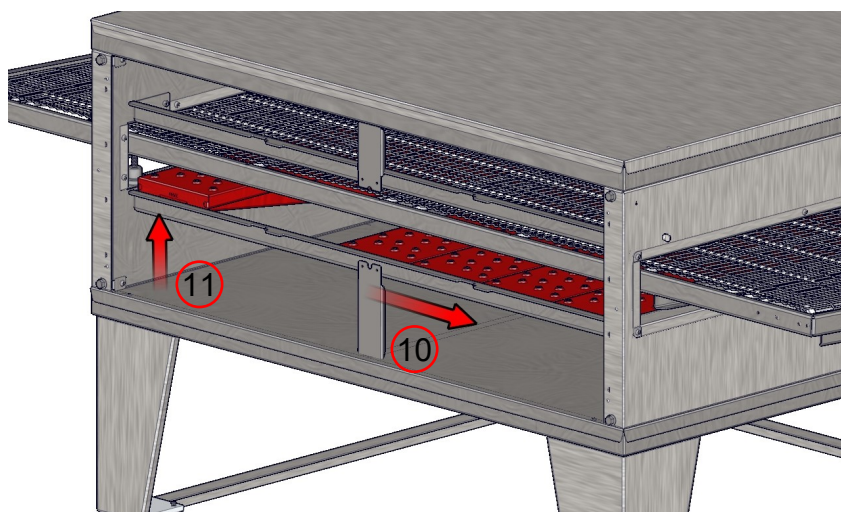
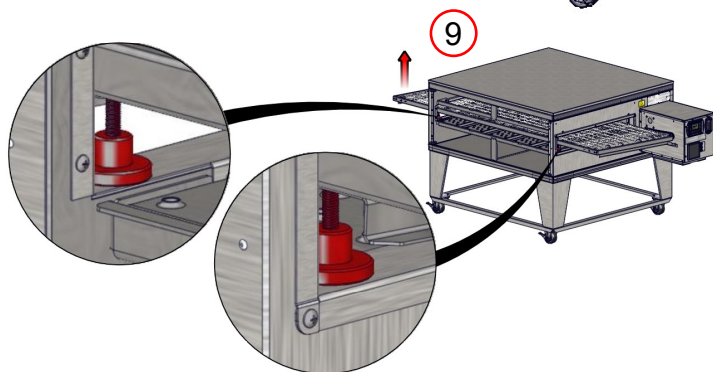
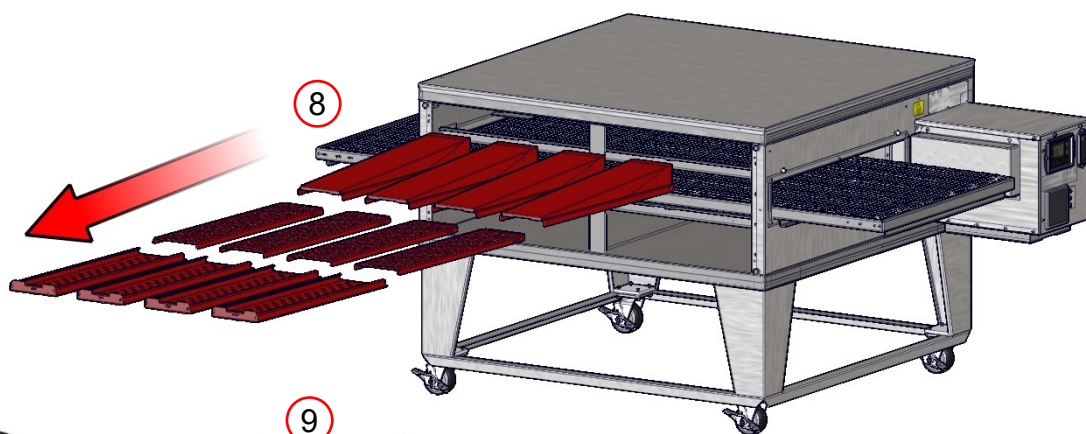
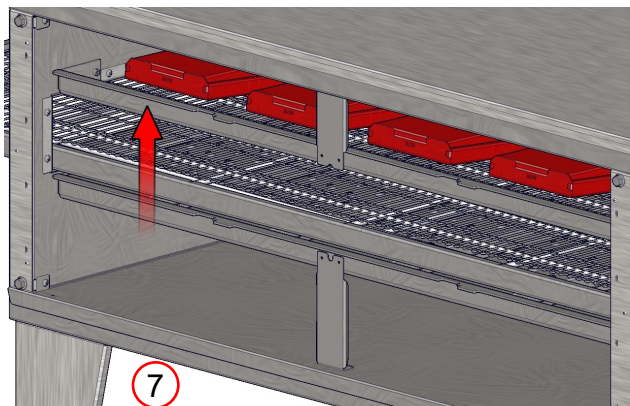

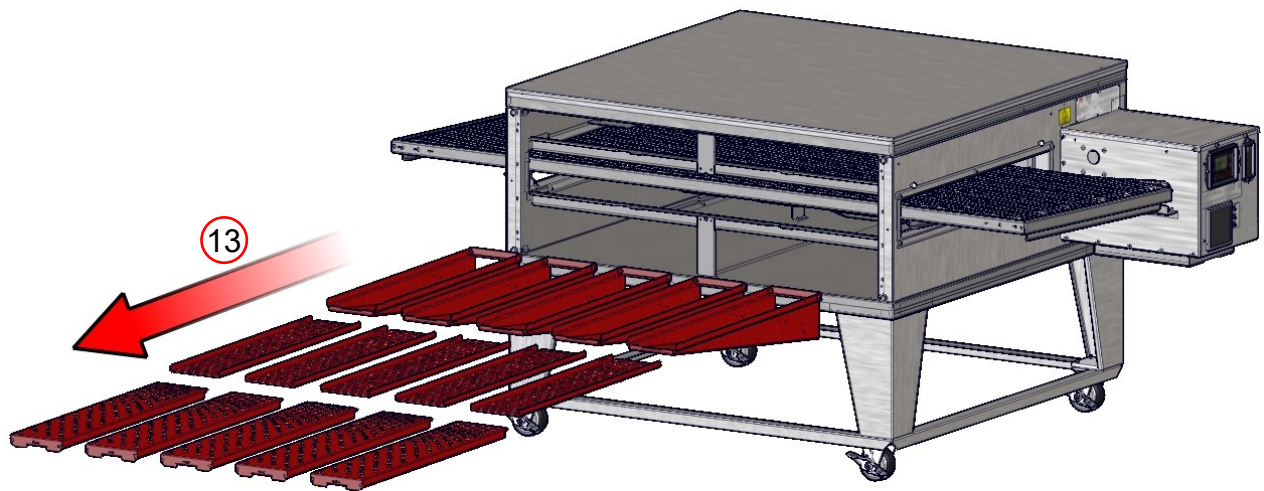
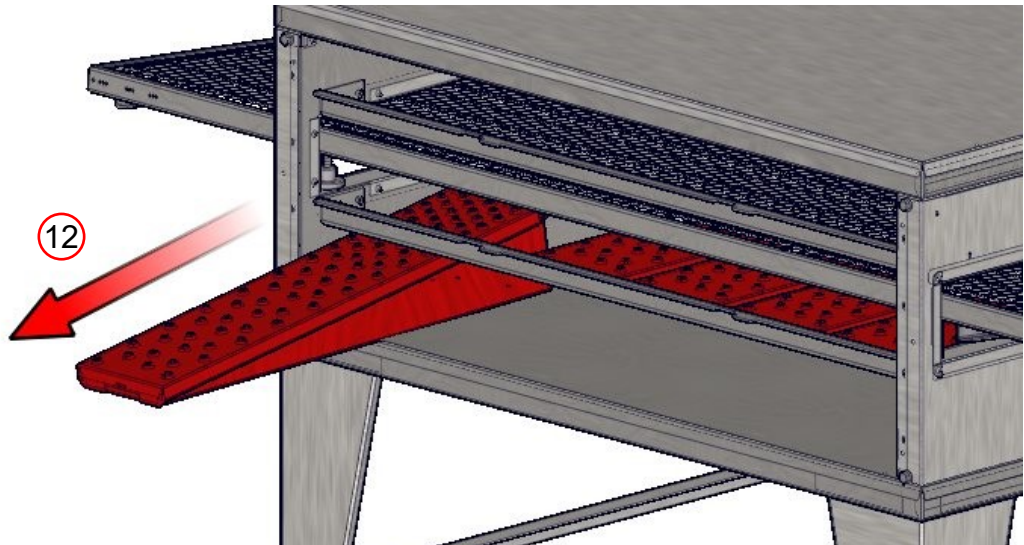

CAUTION

DO NOT spray liquid cleaning agents in the slots and holes in the rear of control box, underneath the control box, or the main fan motor cover.

As with any appliance, periodic maintenance is required. Many factors affect this schedule such as product mix and hours of usage. An example schedule is included.



Oven must be cool and the electric cord unplugged before any cleaning or maintenance is performed.

DANGER

Oven Maintenance Schedule					
		Daily	Weekly	Monthly	Semi-Annual
Cleaning					
	Empty Crumb Trays	<input type="checkbox"/>			
	Wipe down Front, Sides, & Top	<input type="checkbox"/>			
	Wipe down Control Box & Control Panel	<input type="checkbox"/>			
	Clean Fan Filters	<input type="checkbox"/>			
	Remove large debris from Conveyor		<input type="checkbox"/>		
	Wipe down Motor Cover		<input type="checkbox"/>		
	Clean Sandwich Window		<input type="checkbox"/>		
	Remove debris from Finger Outers			<input type="checkbox"/>	
	Remove debris from inside Bake Chamber			<input type="checkbox"/>	
	Remove debris from Main Fan Motor			<input type="checkbox"/>	
	Clean Finger Outers				<input type="checkbox"/>
	Clean inside Bake Chamber				<input type="checkbox"/>
	Clean Conveyor Assembly				<input type="checkbox"/>
Inspection					
	Check Fan Filters for dirt	<input type="checkbox"/>			
	Check Conveyor Wire Belt for Stretch		<input type="checkbox"/>		
	Check Conveyor Drive Roller Chain for Stretch			<input type="checkbox"/>	
Adjust					
	Conveyor Wire Belt			<input type="checkbox"/>	
Lubricate					
	Lubrication of Window Pins W/ Food Grade Grease			<input type="checkbox"/>	
	Conveyor Drive Roller Chain				<input type="checkbox"/>
Replace					
	Fan Filters				<input type="checkbox"/>

- Do not use caustic cleaners on the control panel. Only use cleaners compatible with Lexan® on the face of the conveyor control.
- To determine if the wire belt is stretched, pull up on the center of the belt at the conveyor opening. If the belt touches the top of the conveyor opening, links will need to be removed to adjust the tension. Refer to Wire Belt Adjustment section of Parts and Service Manual to remove links.
- Do not use caustic cleaners on the conveyor bearings.
- Do not use abrasive cleaners or abrasive pads.
- Do not use water jet (high pressure water stream) to clean the oven.

Contact a factory representative or a local service company to perform all other maintenance and repairs. (For warranty work, contact XLT first. Failure to contact XLT prior to contacting a repair company for warranty work voids any and all warranties.)

Proper Cooking

Experimentation is about the only way to determine proper time and temperature settings. While a food product may look perfectly cooked on the outside, the inside may be undercooked. A thermometer is necessary to determine if food items are being properly cooked. Most health departments have rules and regulations that establish minimum temperatures for internal food temperatures. Most operators want to cook foods as fast as possible in order to serve more customers per hour. However, cooking foods slower is the only way to achieve a proper internal temperature. If your food products look acceptable on the outside, but have an internal temperature that is too low, then lowering the temperature and decreasing the belt speed (thereby increasing the cook time), will be necessary.

Several factors may affect the cooking performance and characteristics:

- Oven temperature (generally affects color)
- Conveyor speed (generally affects doneness)
- Finger arrangement
- Altitude
- Pans versus screens
- Dough thickness
- Cheese type
- Raw ingredient temperature (frozen?)
- Quantity of toppings

XLT ovens can be configured to cook a wide variety of food items. This is accomplished by designing a finger group to control the baking characteristics. Generally speaking, most cooking is a “bottom up” process. The hot air from the bottom row of fingers has to go through the conveyor (a distance of about 2” / 50.8mm), heat the pan or screen, and then actually cook the food. The hot air from the top, on the other hand, basically only has to melt and re-heat precooked toppings. Consequently, most operators will use the oven with the fingers arranged so that a lot more air is directed to the bottom of the food than to the top. Finger cover plates are available that have six rows of holes, four rows of holes, two rows of holes, and no holes (or blank cover plates). A typical finger arrangement might have most or even all fingers on the bottom “full open”, that is fingers with all six rows of holes, and only two or three fingers on top with four or six rows of holes. The top fingers can be arranged in a symmetrical pattern or can be shifted asymmetrically to either the entrance or exit end of the conveyor. We encourage you to experiment by trying different finger arrangements, temperatures and belt speeds. XLT can assist you with your oven/product configurations.

Mechanical Function

If your oven does not function properly, please verify the following conditions:

1. Verify that the power cord to the oven is connected and/or plugged in if equipped with a plug and receptacle.
2. Check all circuit breakers on the oven control panel and on the back of the control box to ensure they have not been tripped.
3. Check to see that the circuit breakers in the building electrical service panel have not been tripped or turned off.
4. Ensure proper voltage, amperage, and wire size.
5. In the case of the oven not lighting properly. Turn off the oven and wait approximately thirty (30) seconds or until the fan stops spinning and turn the oven back on.
6. (World Installations) If using the Sail Switches check the HUI for error messages relating the Sail Switch sequencing.



Proceed with caution and read the following instructions carefully when unplugging the units.

Hard Reset

If your oven does not function properly, perform a hard reset. First, power down the unit then unplug the unit from all electrical power. Leave the unit unplugged for one (1) minute. Once this is done, plug the unit back in and turn on the power.

LUI Service Error Codes

Display Alarm	MC LED	Error Determination	Troubleshooting
Oven Probe	Alarm LED on. Flash HEAT LED. All other LED's operate as normal.	Temp Sensor Error, Open or Short. Temp <40F (4C) or >700F (371C)	Perform A Hard Reset. If Error Still Exists, Contact XLT.
PCB Temp Probe	Alarm LED on. Flash HEAT LED. All other LED's operate as normal.	Temp Sensor Error, Open or Short.	Perform A Hard Reset. If Error Still Exists, Contact XLT.
Ignition Error	Alarm LED on. Flash HEAT LED. All other LED's operate as normal.	From Ignition enable (run) signal, if oven doesn't see 25F (-4C) temp rise in three (3) minutes. If restart (actual temp within 50F (10C) of set point) error timing ten (10) minutes.	Perform A Hard Reset. If Error Still Exists, Contact XLT.
Over Temp	Alarm LED on. Flash HEAT LED. All other LED's operate as normal.	Temp is 50F (10C) over set point for period > one (1) minute. If user adjusts set point lower, inhibit alarm until new set point is reached.	Perform A Hard Reset. If Error Still Exists, Contact XLT.
Under Temp	Alarm LED on. Flash HEAT LED. All other LED's operate as normal.	Once set point is reached, the Actual is 15F (-9C) under set point for more than thirty (30) minutes. If user adjusts set point, reset timer.	Perform A Hard Reset. If Error Still Exists, Contact XLT.
Over Speed	Alarm LED on. Flash CONVEYOR LED. All other LED's operate as normal.	Speed > thirty (30) seconds fast Duration vs. Set Point	Perform A Hard Reset. If Error Still Exists, Check LUI Settings. If Settings Are Correct, Perform A Pan Test To Confirm Settings. If Error Still Exists, Contact XLT.
Under Speed	Alarm LED on. Flash CONVEYOR LED. All other LED's operate as normal.	Speed > thirty (30) seconds slow Duration vs. Set Point	Check Drive Chain and Sprocket To Verify Proper Working Condition. Perform A Hard Reset. If Error Still Exists, Check LUI Settings. If Settings Are Correct, Perform A Pan Test To Confirm Settings. If Error Still Exists, Contact XLT.
Software Error	Alarm LED flash. All other LEDs off.	Internal Software Error	Check for pinched wires. Perform A Hard Reset. If Error Still Exists, Contact XLT.
EEPROM Error	Alarm LED flash. All other LEDs off.	Bad Checksum	Perform A Hard Reset. If Error Still Exists, Contact XLT.
Key Short	Alarm LED flash. All other LEDs off.	Any Key Shorted > one (1) minute.	Clean LUI Screen. Perform A Hard Reset. If Error Still Exists, Contact XLT.
Comm Error	Alarm LED flash. All other LEDs off.	Internal Software Error	Perform A Hard Reset. If Error Still Exists, Contact XLT.
Hi Alarm	Alarm LED on. Flash HEAT LED. All other LED's operate as normal.	Hi Alarm set point exceeded.	Perform A Hard Reset. If Error Still Exists, Contact XLT.
Main Fan Low Amps	Alarm LED on. Flash FAN LED. All other LED's operate as normal.	Amps below min level per Main Fan Amp level table for ten (10) seconds.	Perform A Hard Reset. If Error Still Exists, Contact XLT.
Main Fan High Amps	Alarm LED on. Flash FAN LED. All other LED's operate as normal.	Amps above max level per Main Fan Amp level table for ten (10) seconds.	Check CB1 To See If It Has Tripped. If Yes, Reset CB1. If No, Perform A Hard Reset. If Error Still Exists, Contact XLT.
Belt Jam	Conveyor LED flash. All other LED's operate as normal.	If the current motor speed is less than 25% of the most recent minimum motor speed.	Check For Obstructions. If No Obstructions Are Found, Check Drive Chain and Sprocket To Verify Proper Working Condition. Perform A Hard Reset. If Error Still Exists, Contact XLT.

If your oven still does not function properly, XLT has qualified customer service personnel that can provide assistance on any type of XLT equipment problem you may experience. Customer Service is available 24/7/365 at 888-443-2751, or visit www.xltovens.com.



Check all local codes prior to installation. Special requirements may be necessary depending upon building material construction. It is the installing contractor's responsibility to ensure that the structure the hood is to be hung from the ceiling, meets all codes, and can support the hood weight.

Purchaser's Responsibility

It is the responsibility of the purchaser:

1. To thoroughly review the floor plans and specifications. The exact location of the oven must be determined before installing the hood.
2. To unload, uncrate, assemble, and install the hood to its intended location.
3. To ensure that electric utilities are installed on site in accordance with local building codes and meet the specifications in this manual.
4. To see that electric utilities are connected properly by a qualified installer using the proper hardware.
5. To ensure a qualified installer has performed an initial start-up procedure.
6. To minimize long and twisted duct runs, and make efforts to have a straight clear path to the roof/wall fan curb.
7. To ensure all hood supporting structures must be strong enough to support the weight of the hood and shrouds. Refer to the Hood Dimensions and Weights page for weight.
8. To maintain the proper clearances from combustible materials according to International Mechanical code (IMC), and National Fire Protection Agency (NFPA) 96, and local mechanical codes.
9. To ensure that the XLT Hood is suspended properly from the ceiling structure.

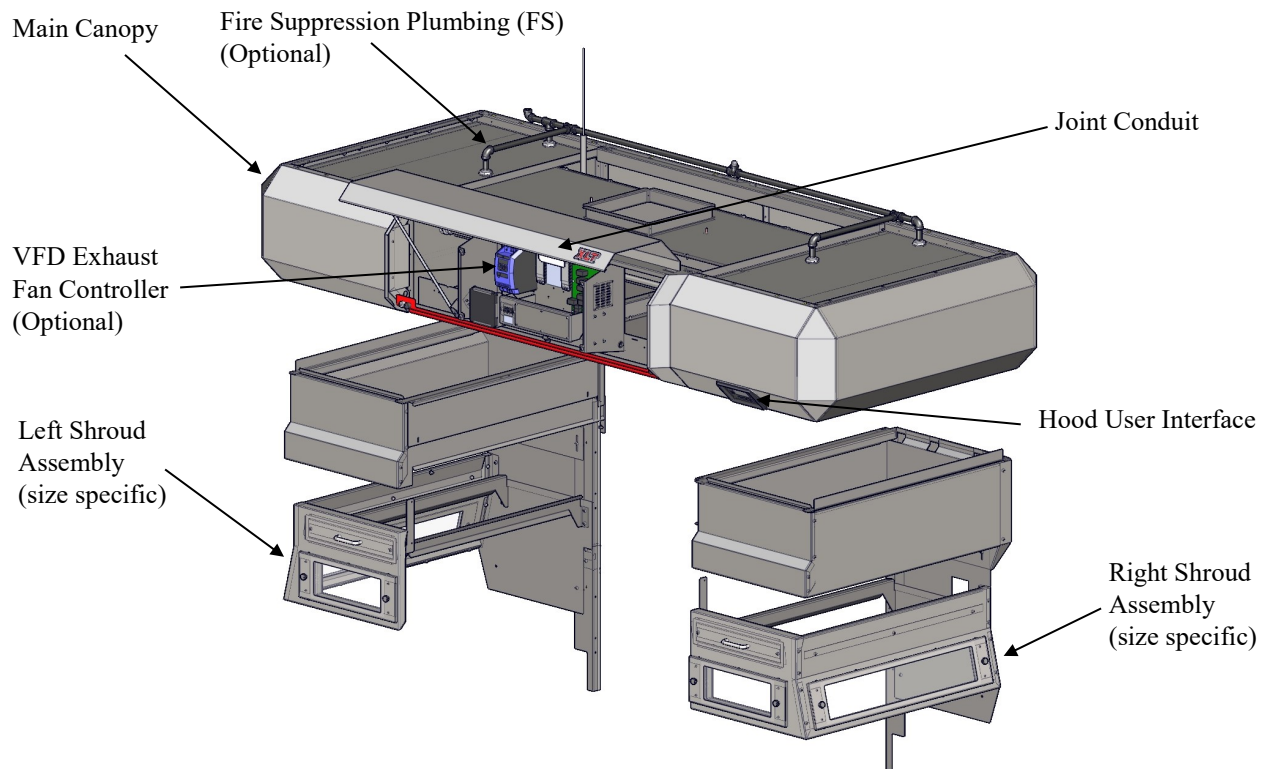

The XLT Hood System consists of three (3) major parts; the Main Canopy, the Shrouds, and the Variable Frequency Drive (VFD) exhaust fan controller.

The Main Canopy serves to collect and transmit heat to the exhaust fan. It houses filters, drives, relays, and the controller. The controller operates both the hood and ovens. The main canopy size is dependent upon oven size.

The Shrouds assist the efficiency of the main canopy by entrapping heat. They are configured for either front and end loading and unloading, and are easily removable for cleaning and maintenance. However, XLT recommends that the shrouds be cleaned in place for convenience and time preservation.

The optional VFD converts input power to variable frequency three-phase output power to control the speed of the exhaust fan. All electric utilities for the hood and exhaust fan connect through the electrical box located on the front of main canopy. The capacitive touch buttons are located on the Hood User Interface on the front of main canopy, and interlock the power function of the hood and oven(s). There are relays that provide interlocks for equipment such as, HVAC dampers, and/or dedicated MUA units and there is an optional relay for fire suppression.

All XLT hoods are available with optional pre-piped for fire suppression, allowing for simple, in-field installations. For fire suppression detailed information see manual XD-9011 Fire Suppression Installation for XLT Hoods and XLT Ovens.

The XLT hood was designed to conform to the requirements of IMC 2015 or current version, which is a Type I hood. It was also designed to have optional fire suppression added to meet requirements of NFPA 96 standard. This was done to allow XLT to better service the requirements of the customer and the associated jurisdictions.

Hood/Shroud Package

Ovens	Hood/Shroud Package	Hood Size	Shroud Size
X3H-1832-xxxxx	02-9F-1832-xxxxx	1832	1832
X3H-2336-xxxxx	02-9F-2336-xxxxx	2440	2336
X3H-2440-xxxxx	02-9F-2440-xxxxx	2440	2440
X3H-3240-xxxxx	02-9F-3240-xxxxx	3240	3240
X3H-3250-xxxxx-DS	02-9F-3250-xxxxx	3255	3250DS
X3H-3255-xxxxx	02-9F-3255-xxxxx	3255	3255
X3H-3855-xxxxx	02-9F-3855-xxxxx	3855	3855
X3H-4455-xxxxx	02-9F-4455-xxxxx	4455	4455

Domestic Hood Crates

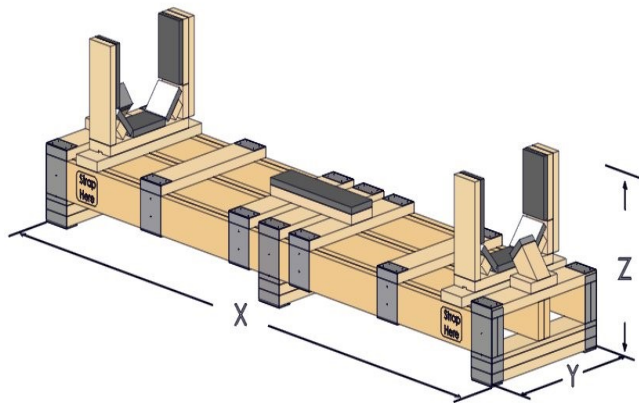

Hood Crate Dimensions			
Oven Model	X	Y	Z (With Hood)
1832	103 3/8 [2626]	27 7/8 [708]	46 3/4 [1187]
2336	103 3/8 [2626]	27 7/8 [708]	52 3/4 [1340]
2440	103 3/8 [2626]	27 7/8 [708]	52 3/4 [1340]
3240	103 3/8 [2626]	27 7/8 [708]	60 3/4 [1543]
3250DS	118 3/8 [3007]	27 7/8 [708]	60 3/4 [1543]
3255	118 3/8 [3007]	27 7/8 [708]	60 3/4 [1543]
3855	118 3/8 [3007]	27 7/8 [708]	66 3/4 [1695]
4455	118 3/8 [3007]	27 7/8 [708]	72 3/4 [1848]

NOTE: All dimensions in inches [millimeters], ± 1/4 [6], unless otherwise noted.
All weights in pounds [kilograms] unless otherwise noted.

International Hood Crates

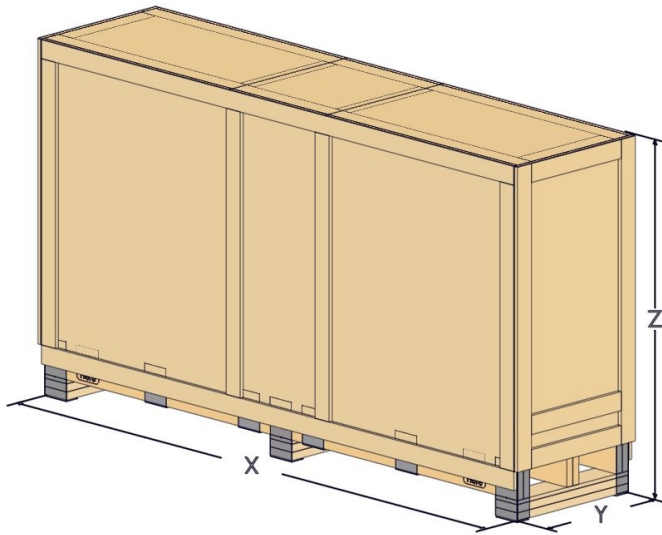

Hood Crate Dimensions			
Oven Model	X	Y	Z (With Hood)
1832	105 [2667]	29 1/2 [749]	65 3/4 [1668]
2336	105 [2667]	29 1/2 [749]	65 3/4 [1668]
2440	105 [2667]	29 1/2 [749]	65 3/4 [1668]
3240	105 [2667]	29 1/2 [749]	65 3/4 [1668]
3250DS	120 [3048]	29 1/2 [749]	65 3/4 [1668]
3255	120 [3048]	29 1/2 [749]	65 3/4 [1668]
3855	120 [3048]	29 1/2 [749]	71 3/4 [1821]
4455	120 [3048]	29 1/2 [749]	77 3/4 [1973]

Shroud Crates

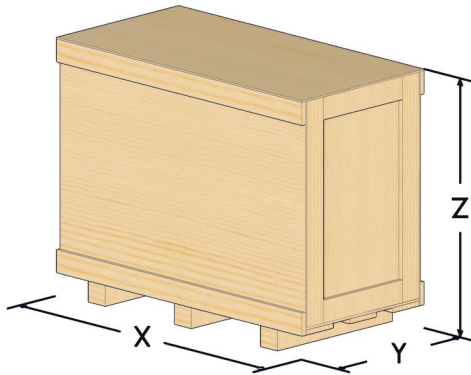

Shroud Crate Dimensions			
Oven Model	X	Y	Z
18xx-1	51 1/4 [1302]	25 1/2 [648]	27 1/2 [699]
18xx-2			
18xx-3	66 1/4 [1683]	25 1/2 [648]	27 1/2 [699]
24xx-1	51 1/4 [1302]	25 1/2 [648]	31 1/2 [800]
24xx-2			
24xx-3	66 1/4 [1683]	25 1/2 [648]	31 1/2 [800]

Shroud Crate Dimensions			
Oven Model	X	Y	Z
32xx-1	51 1/4 [1302]	25 1/2 [648]	39 1/2 [1003]
32xx-2			
32xx-3	66 1/4 [1683]	25 1/2 [648]	39 1/2 [1003]
38xx-1	51 1/4 [1302]	25 1/2 [648]	45 1/2 [1156]
38xx-2			
38xx-3	66 1/4 [1683]	25 1/2 [648]	45 1/2 [1156]

NOTE: All dimensions in inches [millimeters], ± 1/4 [6], unless otherwise noted.
All weights in pounds [kilograms] unless otherwise noted.

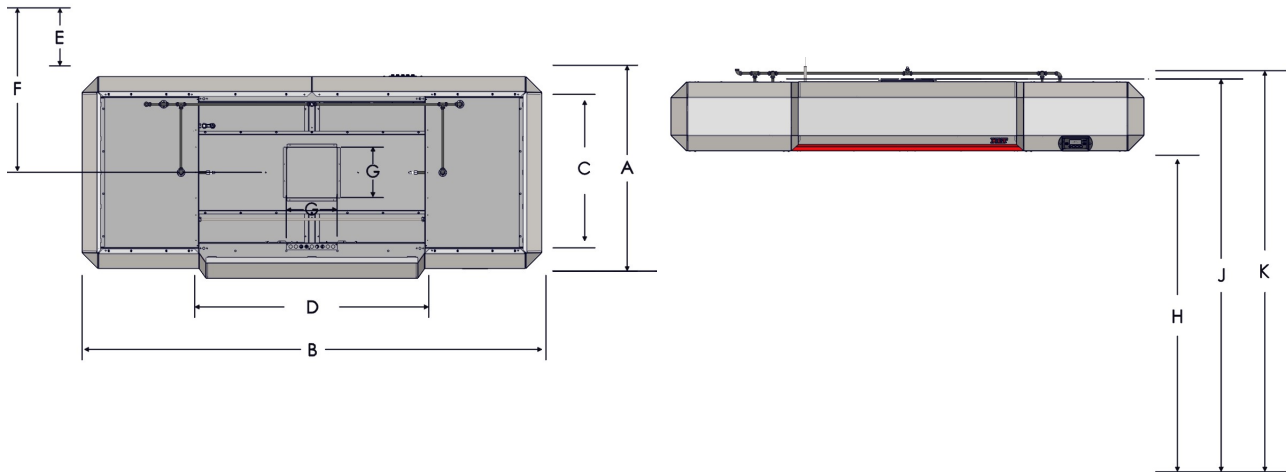

All dimensions are from finished floor

Oven Model	Hood Dimensions										Hood Only Weights	Hood & Shroud Weights		Crated Weight Domestic			Crated Weight			
	A	B	C	D	E*	F*	G	H	J	K		Double	Triple	Hood	Double	Triple	Hood	Double	Triple	
1832	33 1/2 [851]	85 1/4 [2165]	21 1/2 [546]	30 1/4 [768]	15 1/4 [387]	31 [787]	12 [305]	69 5/8 ±1/8 [1768]	85 3/8 [2169]	88 1/8 [2238]	271 [123]	454 [206]	511 [232]	477 [216]	629 [285]	741 [336]	561 [254]	762 [346]	825 [374]	
2440	39 1/2 [1003]	93 1/4 [2369]	27 1/2 [699]	38 1/4 [972]		34 [864]					38 [965]	349 [142]	513 [233]	574 [260]	525 [238]	688 [312]	811 [368]	609 [276]	828 [376]	895 [406]
3240	47 1/2 [1207]	93 1/4 [2369]	35 1/2 [902]	38 1/4 [972]		38 [965]					38 [965]	389 [176]	579 [281]	646 [293]	564 [256]	753 [342]	891 [404]	648 [294]	901 [409]	975 [442]
3250 DS	47 1/2 [1207]	108 1/4 [2750]	35 1/2 [902]	53 1/4 [1353]		38 [965]					38 [965]	389 [176]	619 [281]	646 [293]	634 [288]	819 [371]	725 [329]	978 [444]		
3255	47 1/2 [1207]	108 1/4 [2750]	35 1/2 [902]	53 1/4 [1353]		38 [965]					38 [965]	389 [176]	619 [281]	687 [312]	634 [288]	819 [371]	962 [436]	725 [329]	978 [444]	1053 [478]
3855	53 1/2 [1359]	108 1/4 [2750]	41 1/2 [1054]	53 1/4 [1353]		41 [1041]					41 [1041]	419 [190]	666 [302]	737 [334]	668 [303]	866 [393]	1017 [461]	765 [347]	1036 [470]	1114 [505]
4455	59 1/2 [1511]	108 1/4 [2750]	47 1/2 [1207]	53 1/4 [1353]		44 [1118]					44 [1118]	442 [200]	712 [323]	786 [357]	694 [315]	911 [413]	1073 [487]	796 [361]	1092 [495]	1175 [533]

Ovens	Hood/Shroud Package	Hood Size	Shroud Size
X3H-1832-xxxxx	02-9F-1832-xxxxx	1832	1832
X3H-2336-xxxxx	02-9F-2336-xxxxx	2440	2336
X3H-2440-xxxxx	02-9F-2440-xxxxx	2440	2440
X3H-3240-xxxxx	02-9F-3240-xxxxx	3240	3240
X3H-3250-xxxxx-DS	02-9F-3250-xxxxx	3255	3250DS
X3H-3255-xxxxx	02-9F-3255-xxxxx	3255	3255
X3H-3855-xxxxx	02-9F-3855-xxxxx	3855	3855
X3H-4455-xxxxx	02-9F-4455-xxxxx	4455	4455

Exhaust Fan And Curb Dimensions			Crated Weight (Stacked)
31 [787]	31 [787]	67 [1702]	185 [84]



* E and F are the minimum distances from either finished combustible or non combustible wall structure.

NOTE: All dimensions in inches [millimeters], ± 1/4 [6], unless otherwise noted.
All weights in pounds [kilograms] unless otherwise noted.

Exhaust Flow Rates VOLUME (min. recommended)										
			Ovens On			18xx	24xx	32xx	38xx	44xx
			Top	Middle	Bottom					
Single	X					500	500	500	500	500
						[14.16]	[14.16]	[14.16]	[14.16]	[14.16]
Double	X					500	500	500	500	500
						[14.16]	[14.16]	[14.16]	[14.16]	[14.16]
	X			X		500	500	670	800	950
						[14.16]	[14.16]	[18.97]	[22.65]	[26.9]
Triple	X					500	500	500	500	500
						[14.16]	[14.16]	[14.16]	[14.16]	[14.16]
	X			X		500	500	670	800	950
						[14.16]	[14.16]	[18.97]	[22.65]	[26.9]
	X			X	X	540	720	960	1140	1360
						[15.29]	[20.39]	[27.18]	[32.28]	[38.51]
	X	X				500	500	670	800	950
						[14.16]	[14.16]	[18.97]	[22.65]	[26.9]
X			X	X	540	720	960	1140	1360	
					[15.29]	[20.39]	[27.18]	[32.28]	[38.51]	
X	X		X	X	540	720	960	1140	1360	
					[15.29]	[20.39]	[27.18]	[32.28]	[38.51]	
X	X	X			540	720	960	1140	1360	
					[15.29]	[20.39]	[27.18]	[32.28]	[38.51]	



All values are CFM [M3/Min] unless otherwise noted. Figures represent TOTAL VOLUME measured at the duct.

In accordance with mechanical codes, make up air must be supplied. For commercial kitchen make up air, the amount is determined by the exhaust hood flow rate requirements and all other exhaust flow rate requirements in the kitchen.

At a minimum, smoke candles must be used for a Capture and Containment (C&C) test. Refer to the Ventilation Requirements disclosed in the Oven section in this manual.

A Test and Balance (TAB) report is recommended after installation has been completed. Below are the minimum items to be included in this report:

- Total airflow on all A/C, Make-Up Air (MUA), and exhaust systems.
- Airflow on each supply and exhaust grille.
- Airflows on exhaust hoods compared to design specifications.

A final air balance report, with any corrections of issues found in the report, will help to insure that your building systems are functioning properly and efficiently.

Refer to “Oven Ventilation Requirements and Guidelines”.

Exhaust Flow Rates VELOCITY (min. recommended)										
		Ovens On			18xx	24xx	32xx	38xx	44xx	
		Top	Middle	Bottom						
Single	X				187.5	187.5	93.75	93.75	93.75	
					[57.15]	[57.15]	[28.58]	[28.58]	[28.58]	
Double	X				187.5	187.5	93.75	93.75	93.75	
					[57.15]	[57.15]	[28.58]	[28.58]	[28.58]	
	X		X		187.5	187.5	125.625	150	178.125	
					[57.15]	[57.15]	[38.29]	[45.72]	[54.29]	
Triple	X				187.5	187.5	93.75	93.75	93.75	
					[57.15]	[57.15]	[28.58]	[28.58]	[28.58]	
		X				187.5	187.5	125.625	150	178.125
						[57.15]	[57.15]	[38.29]	[45.72]	[54.29]
			X			202.5	270	180	213.75	255
						[61.72]	[82.3]	[54.86]	[65.15]	[77.72]
	X	X				187.5	187.5	125.625	150	178.125
						[57.15]	[57.15]	[38.29]	[45.72]	[54.29]
	X		X			202.5	270	180	213.75	255
						[61.72]	[82.3]	[54.86]	[65.15]	[77.72]
		X	X			202.5	270	180	213.75	255
						[61.72]	[82.3]	[54.86]	[65.15]	[77.72]
X	X	X			202.5	270	180	213.75	255	
					[61.72]	[82.3]	[54.86]	[65.15]	[77.72]	



All values are FPM [M/Min] unless otherwise noted. Figures represent VELOCITY measured at the Grease Filter.



Verify through building codes what the minimum required CFM velocity is and that it is greater than the values listed in the above table for the size and quantity of ovens in below the hood.

The VELOCITY readings above are obtained by holding an anemometer 3” away from the Grease Filter. Take several readings in different locations across the filters and average the results.

Inputs into Electrical

XLT Hood Electric Utility Specifications			
	# of Circuits	Rating	Purpose
Standard	1	208/240 VAC, 1 Phase, 60 Hz, 6 Amp	VFD Controller
	up to 3	120 VAC, 1 Phase, 60 Hz, 20 Amp	Ovens
World	1	230 VAC, 1 Phase, 50 Hz, 6 Amp	VFD Controller
	up to 3	230 VAC, 1 Phase, 50 Hz, 10 Amp	Ovens



Do not connect to 3 Phase power. 1 Phase Only.

Outputs from Electrical

The XLT Hood system provides:

- Up to three (3) switching outputs for HVAC damper and/or dedicated unit
- One (1) 230 VAC, 10 Amp, variable frequency, three phase power output for the ventilation exhaust fan
- Up to three (3) receptacles for ovens
- One (1) 24 VDC fire alarm signal

Relocation cords that will physically connect into oven(s).

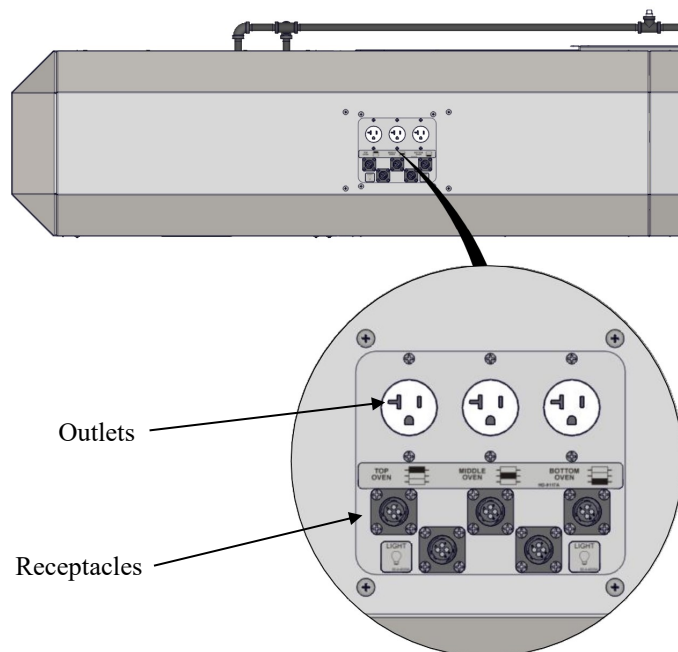

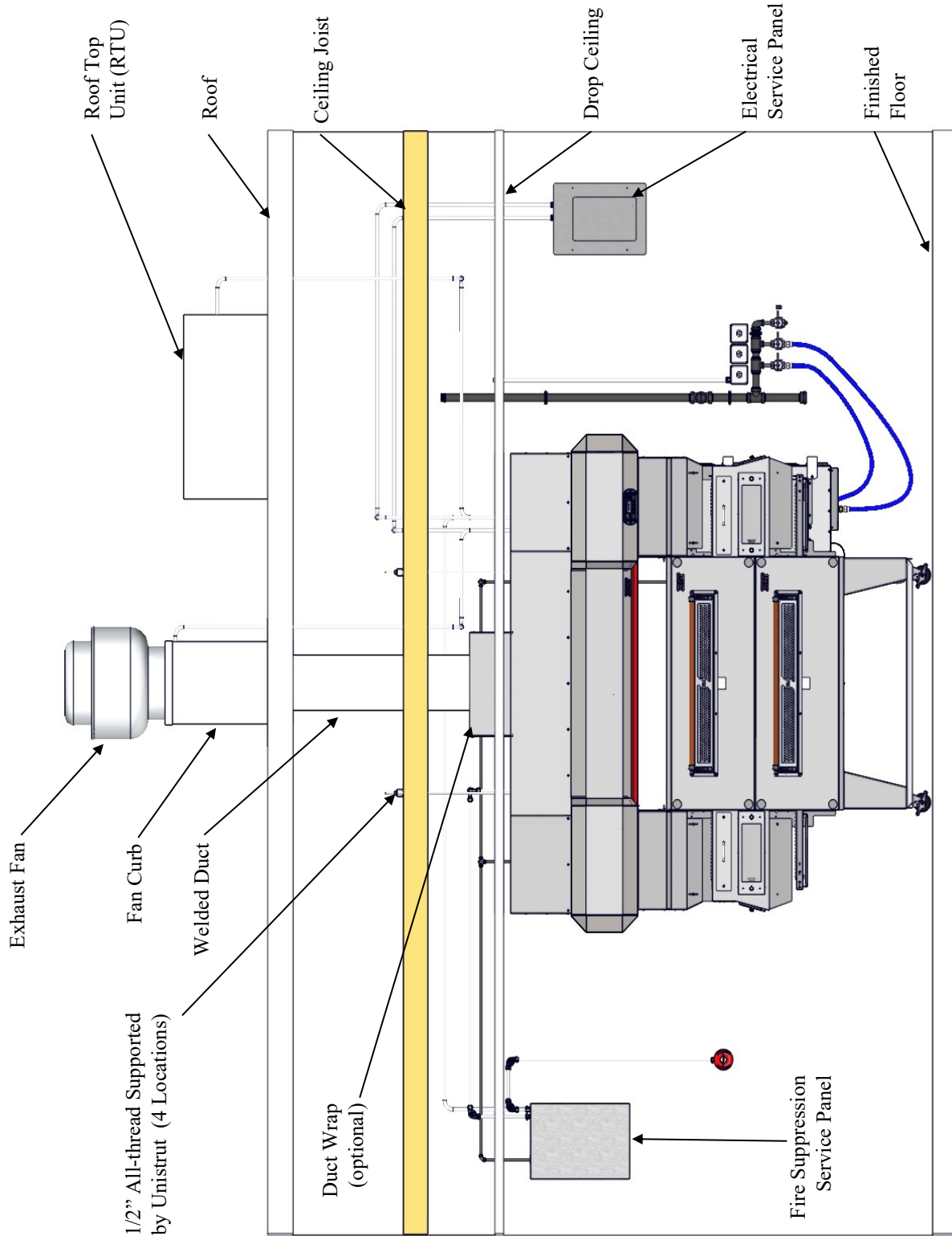

*The above image shown is a Gas Oven Configuration

All structural members, electrical and fire suppression equipment shown for reference only.

VFD Control Box

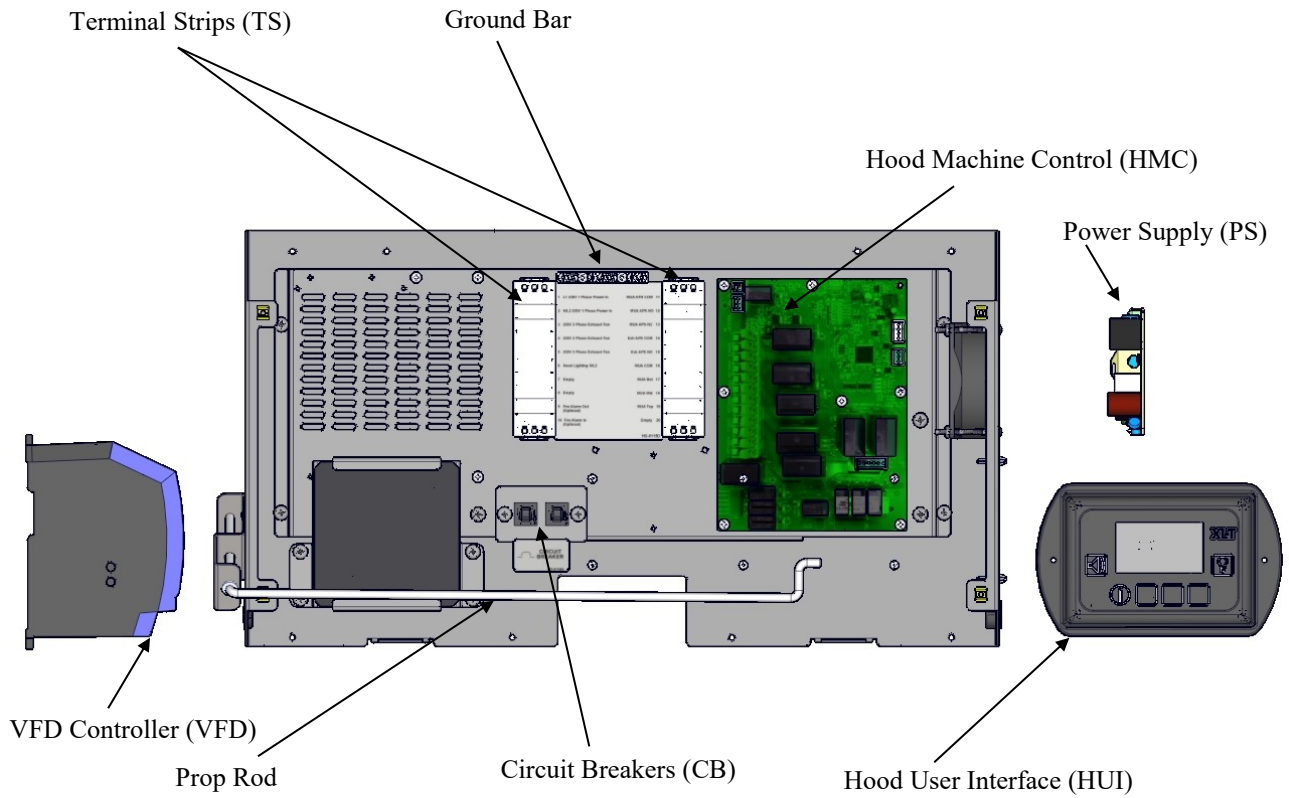

VFD Control Box (Cover removed)

Input Power to VFD Controller - Standard (208/240V Single Phase)

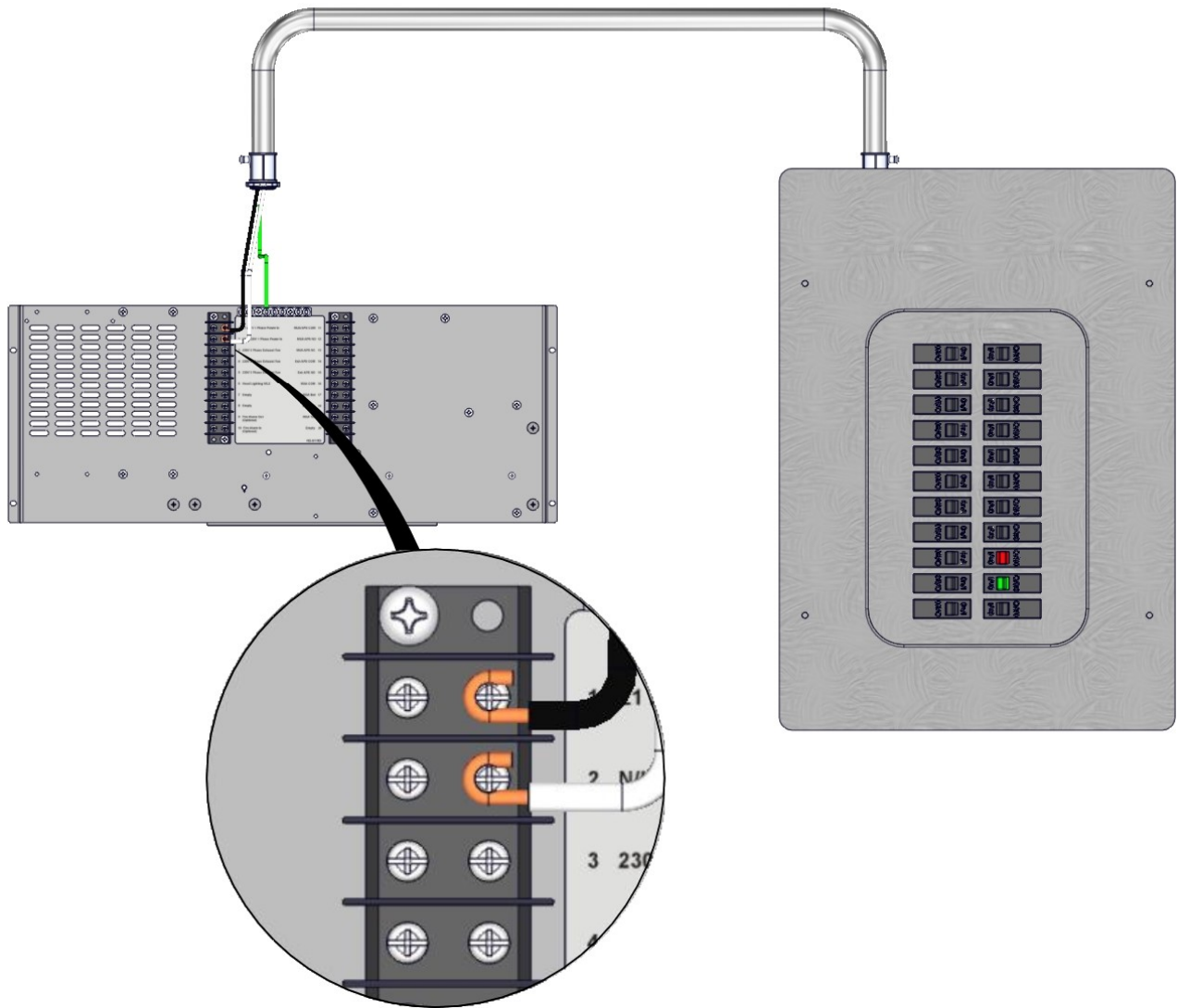

Input Power to VFD Controller - World (230V / 50Hz)

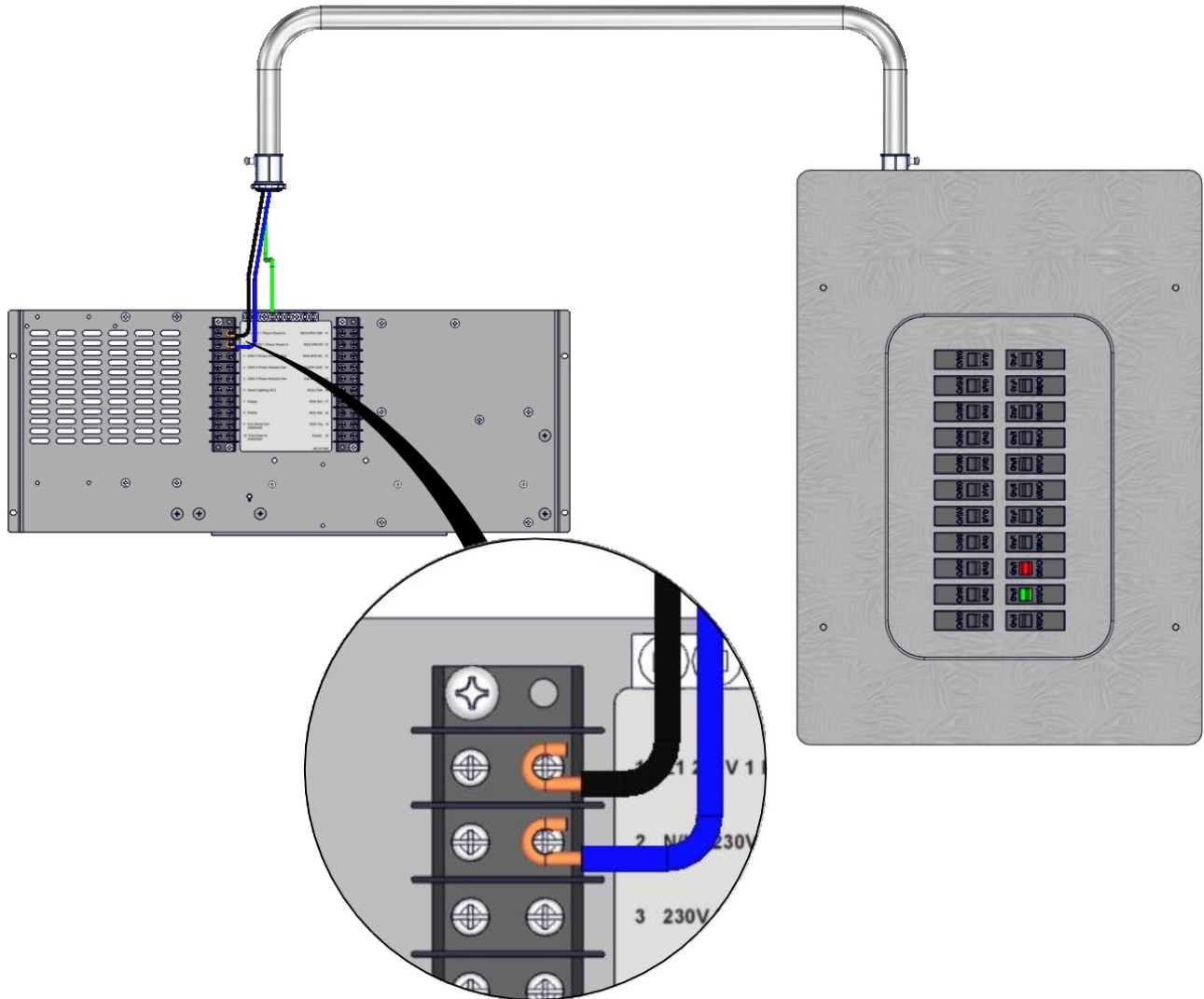

Output Power from VFD to Exhaust Fan - Standard

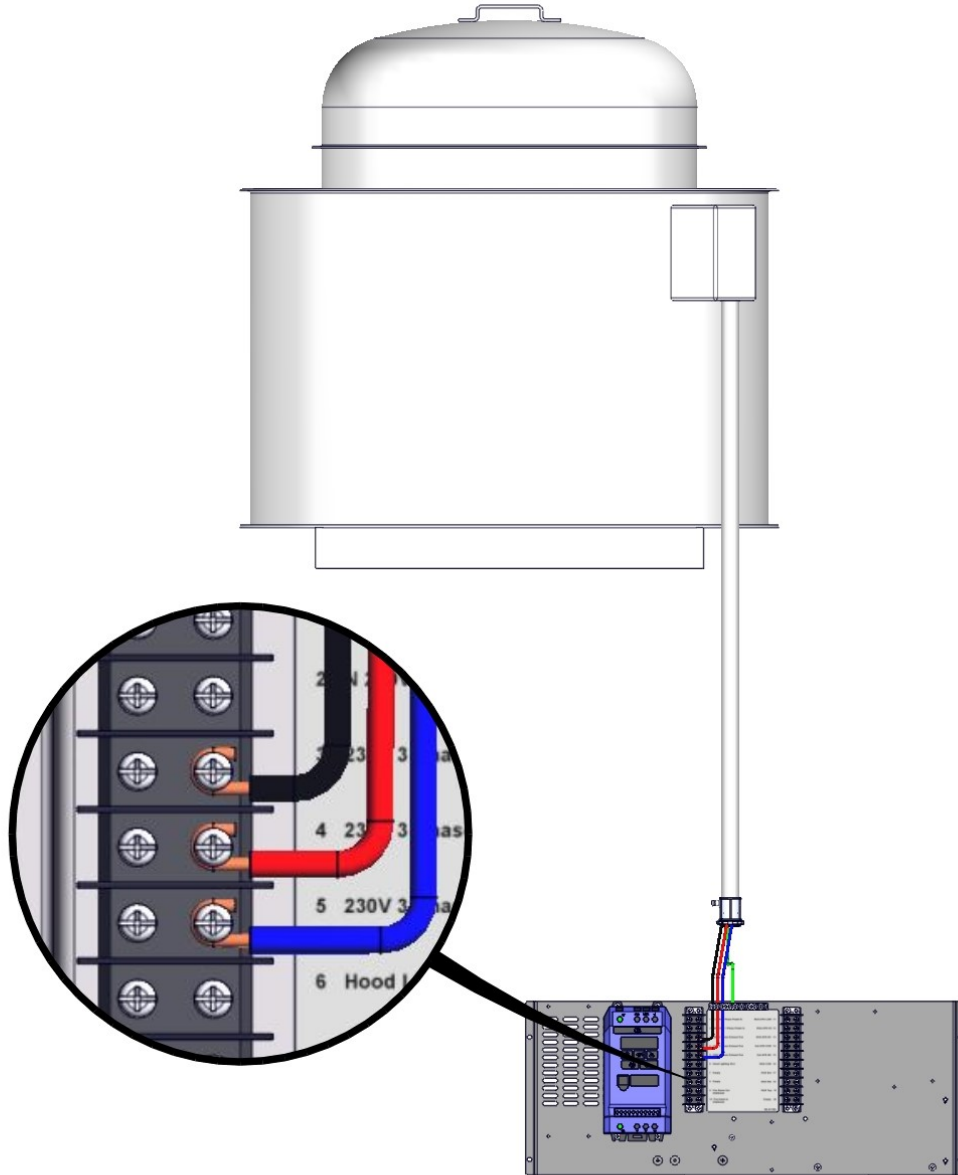

Output Power from VFD to Exhaust Fan - World

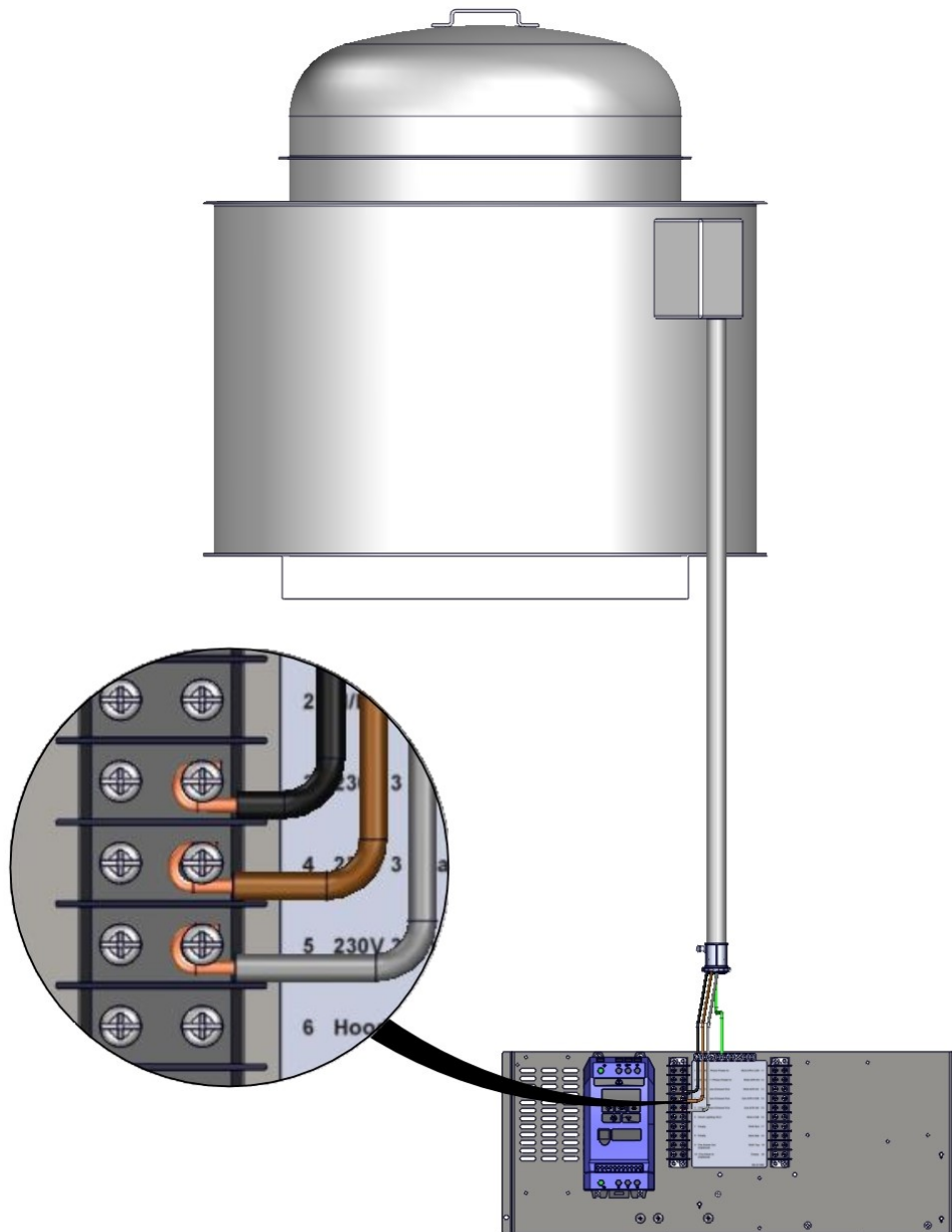

MUA Damper Relays - Single Output - Voltage and Frequency

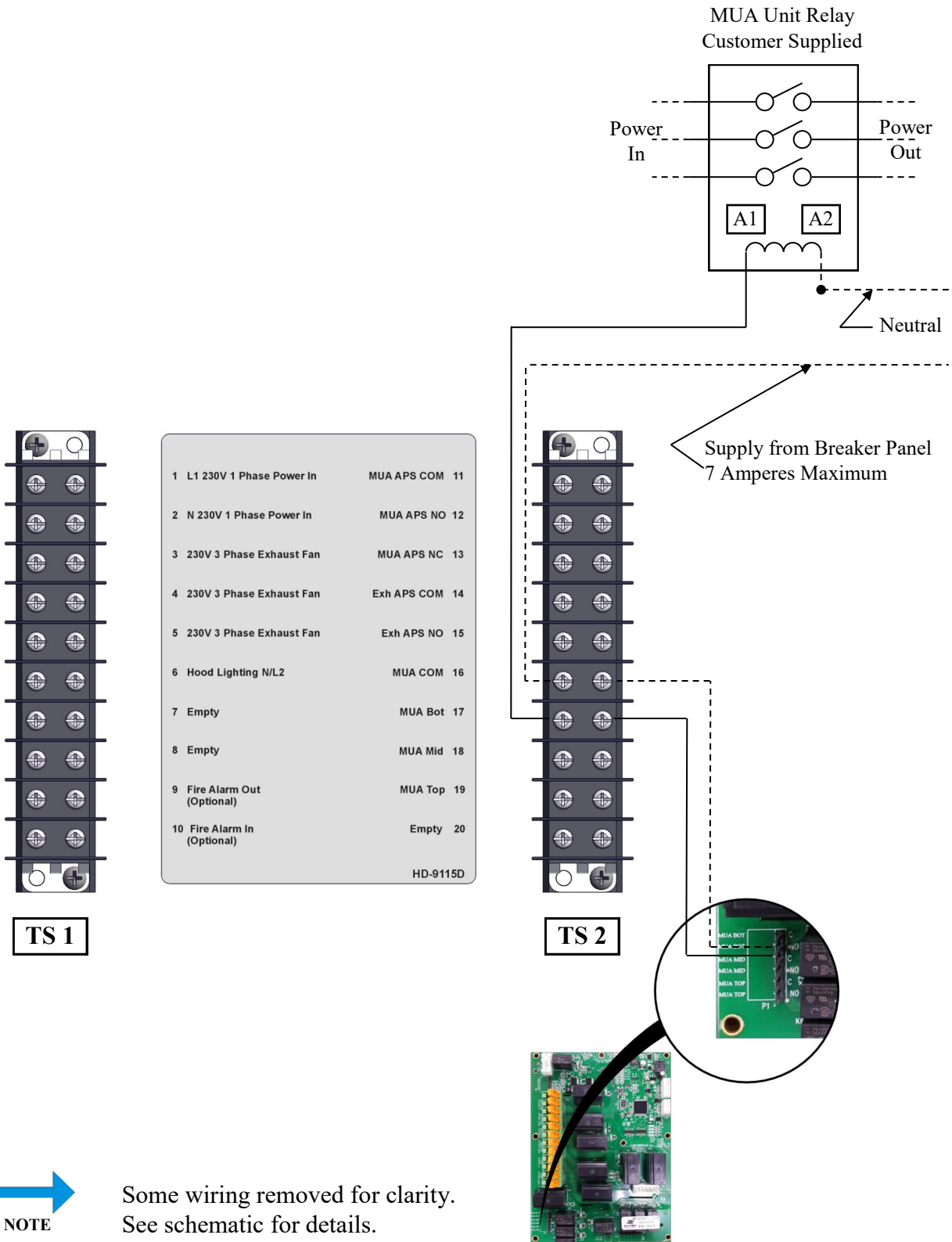

MUA Damper Relays - Multiple Output - Voltage and Frequency

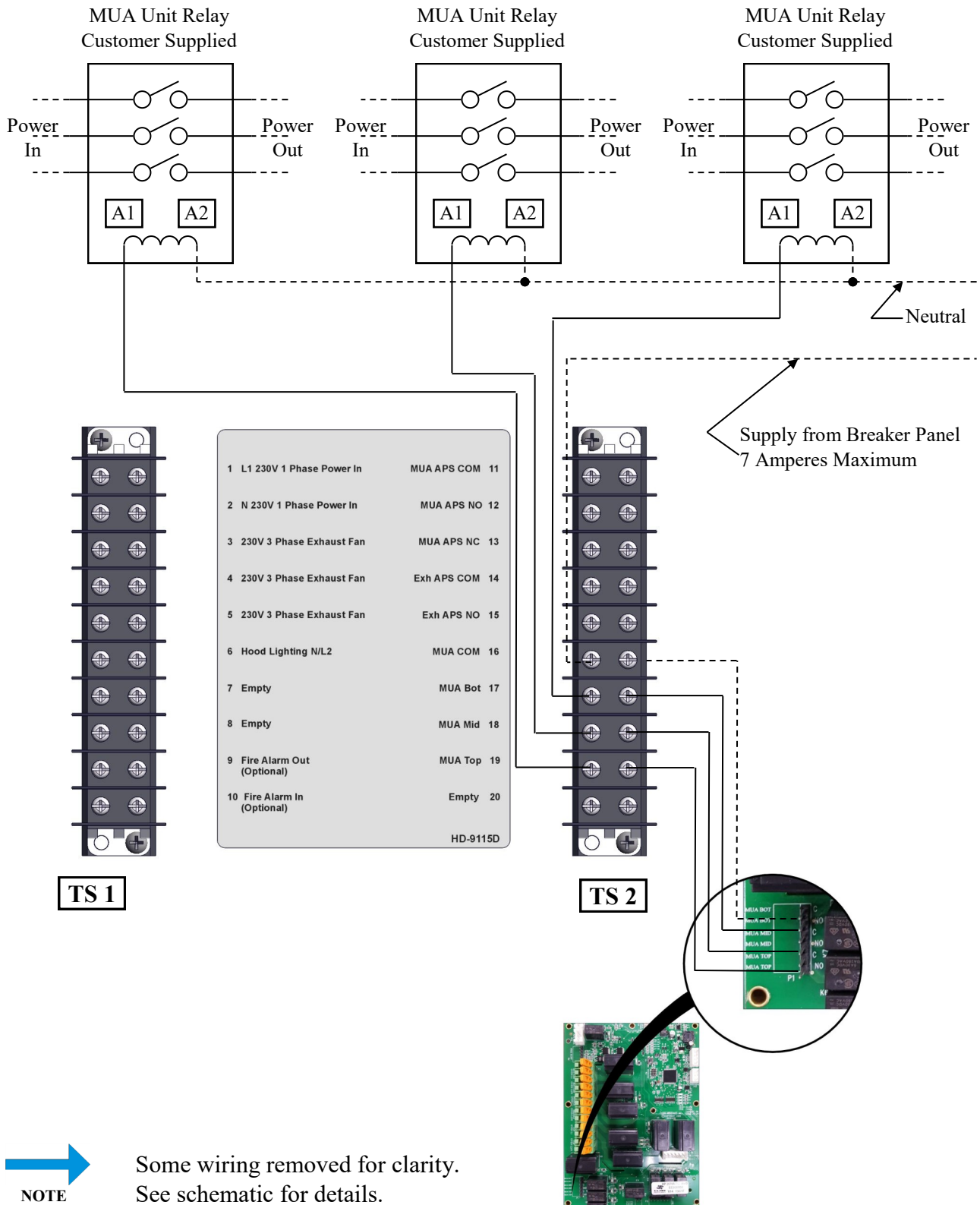

World (230V / 50Hz)-W/Air Proving Switches

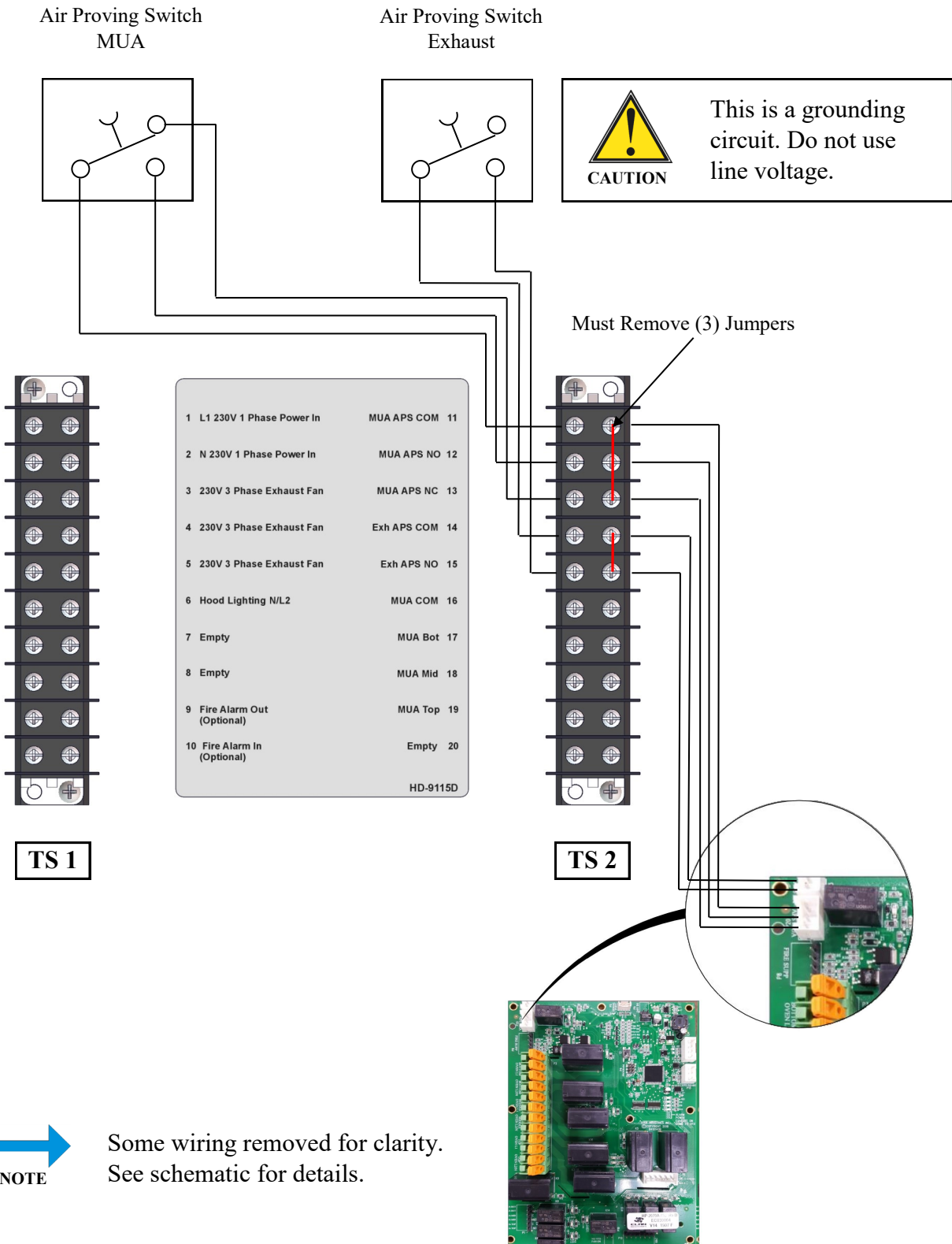

Fire Alarm Relay - Voltage and Frequency

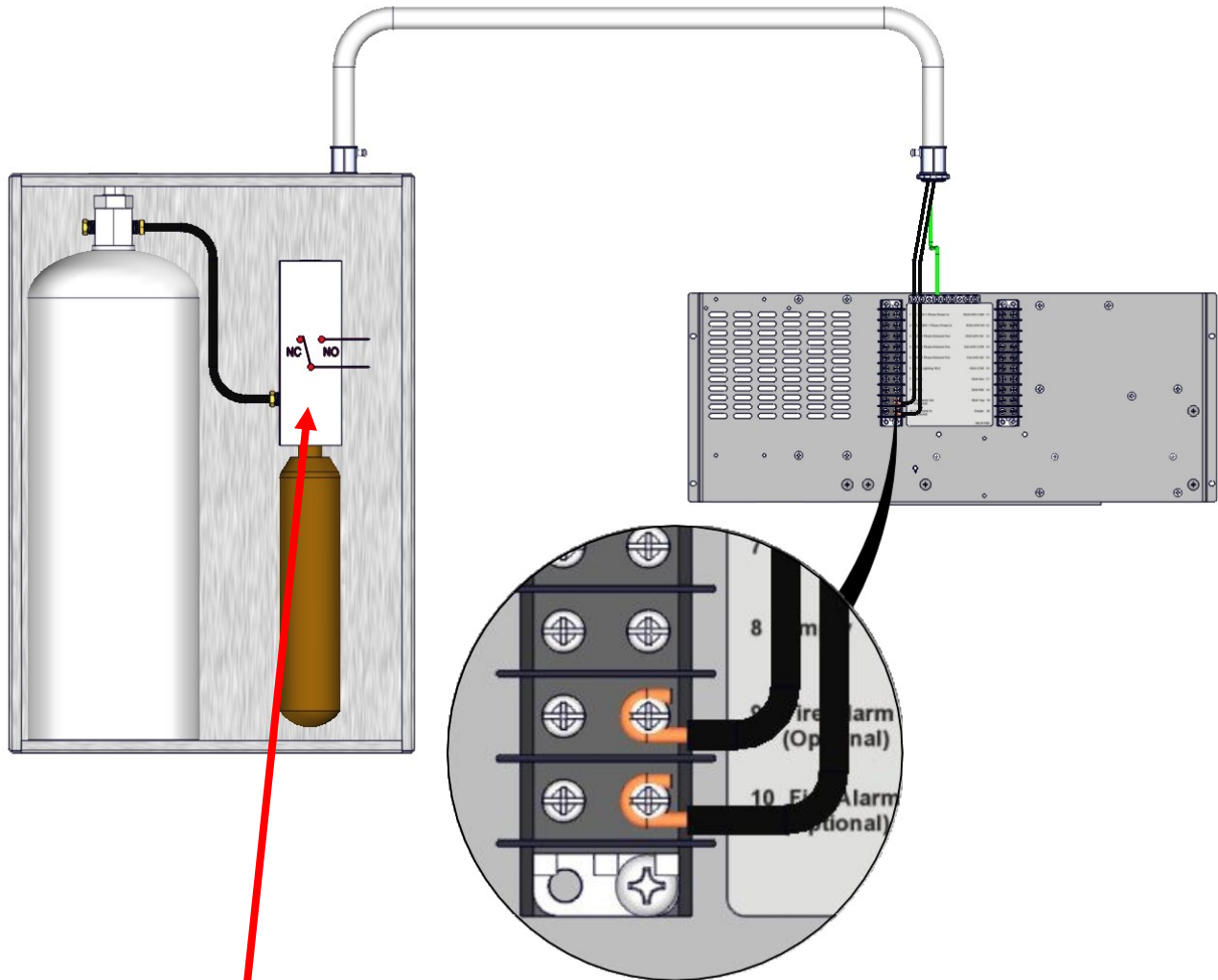

Connect wires from the Junction Box to the Normally Open (NO) contacts in the Fire Suppression cabinet.



TS1-10R will have voltage when the Fire Suppression system has been activated.



Oven must be cool and the electric cord unplugged before hood assembly begins.



If the oven is to be removed from its installed location for hood assembly and installation, the following procedure is to be followed:

1. Unplug electric cord.
2. Unlock casters.
3. Disconnect restraint.
4. When hood assembly is complete, move oven to original location.
5. Connect restraint.
6. Lock casters.
7. Plug in electric cord.
8. Follow normal lighting instructions.



TIP

Read and understand the next steps first. They illustrate how to install the components of the hood onto the ovens, and to install the hood.

Prepare Hood - Install Hood Transition Rails

①

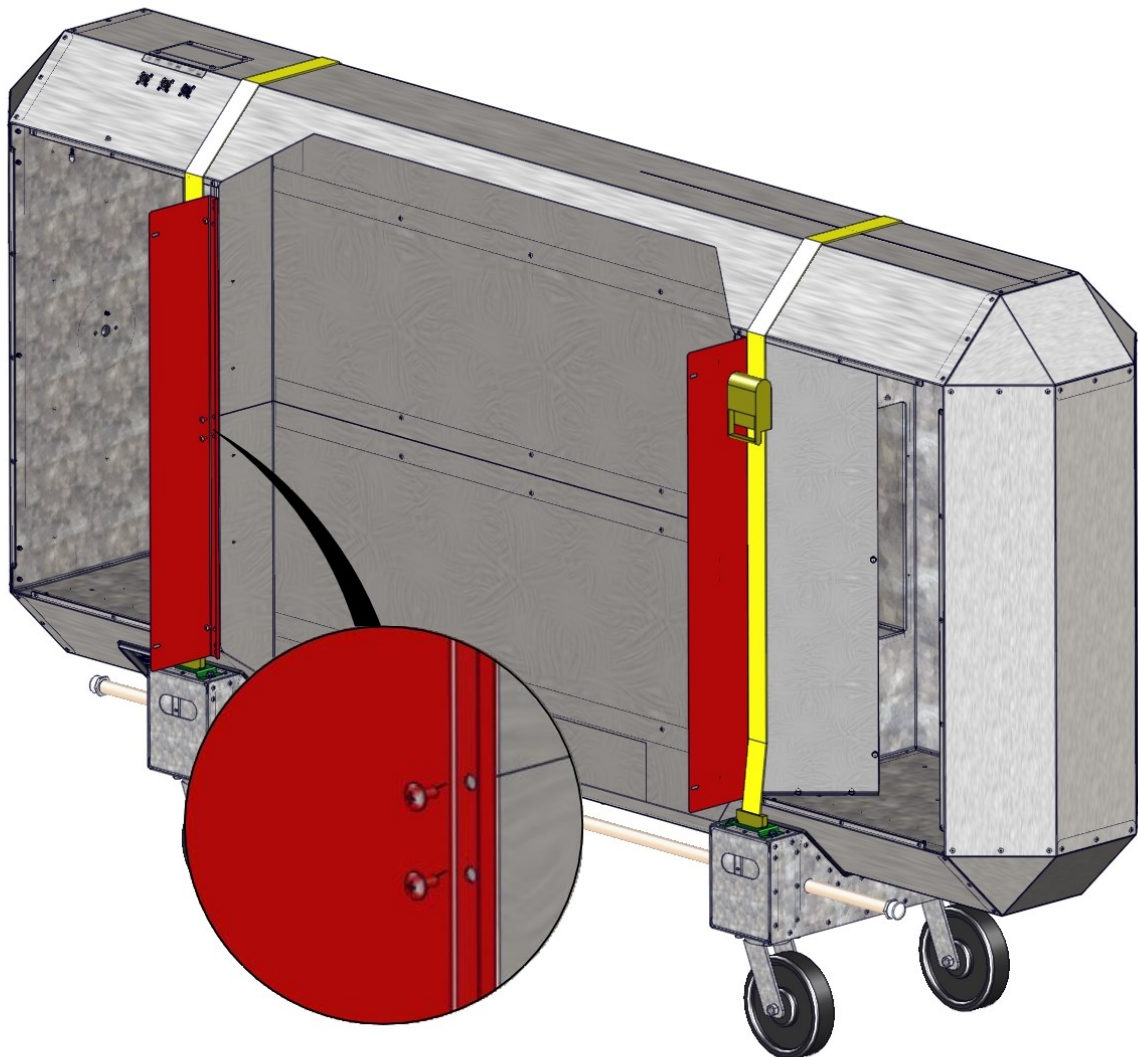

Lifting Gear Setup

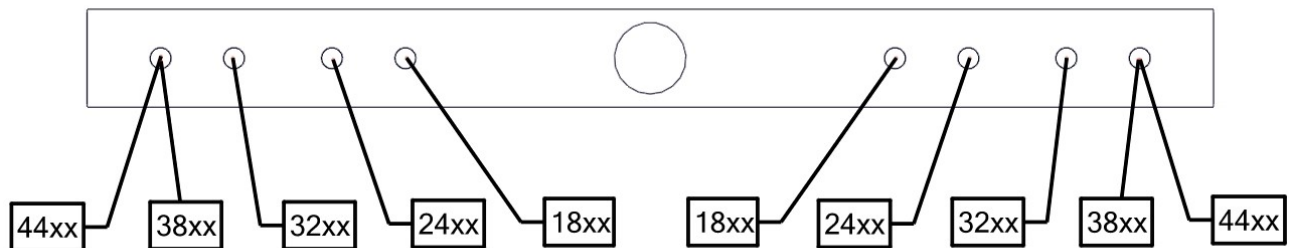
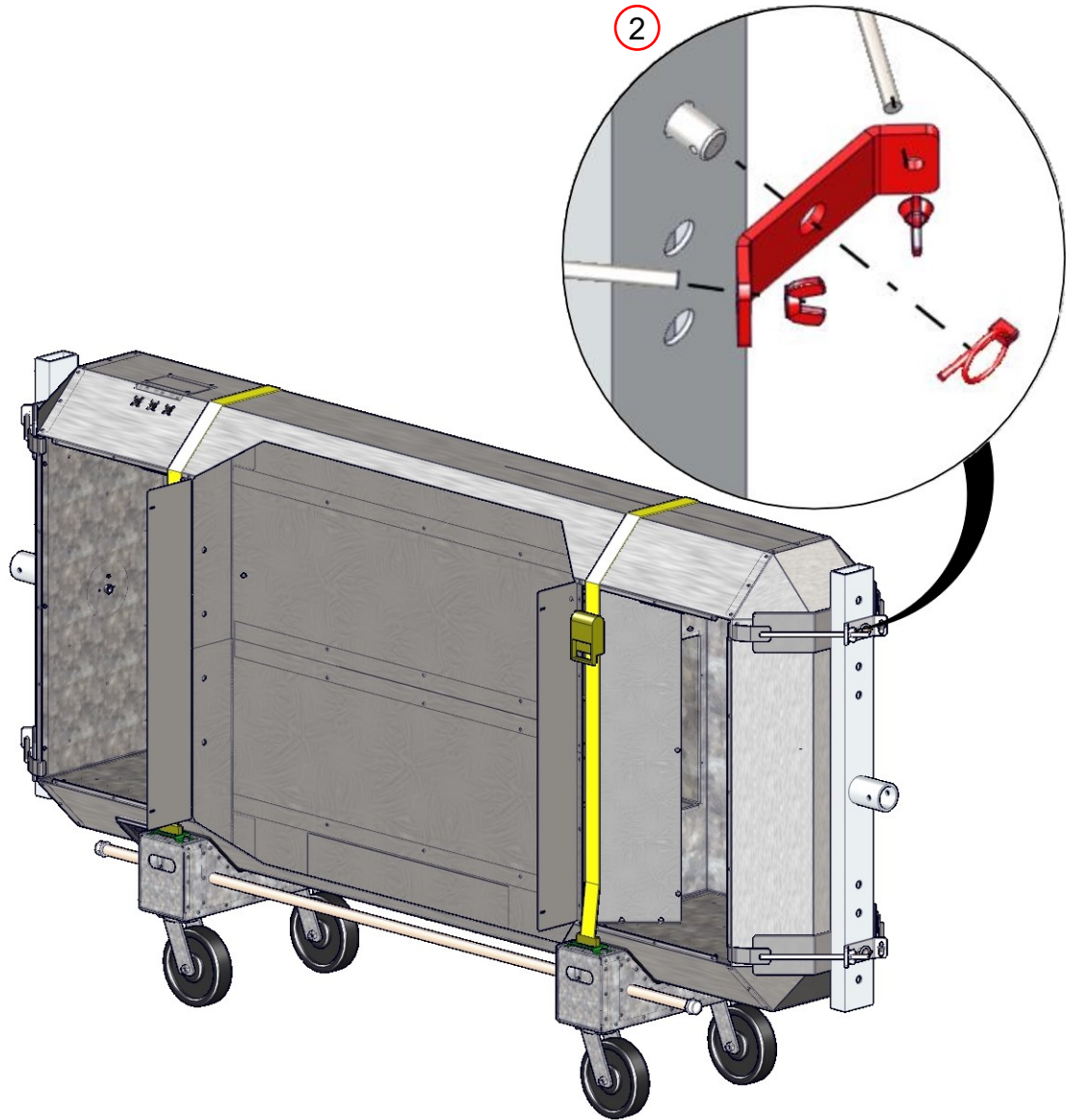

All 44xx hood models will work in the same slot as 38xx hood models when utilizing the current lifting equipment. Hooks will not be seated clear to either box end edge.

Warning and Safety Information

An XLT hood can easily be moved with the proper lifting equipment. The use of XLT approved lifting equipment is highly recommended. Contact XLT for more information.



- These hood is heavy and can tip or fall causing bodily injury.
- NEVER place any part of your body beneath any hood that is suspended by the lifting jacks. A crush hazard exists if the hood falls or slips.
- DO NOT place your hands on the lifting jack vertical pole beneath the jack's winch. As the jack's winch descends when you turn the jack handle, a pinch point is created between the winch and the pole.



BE CAREFUL when rolling the hood on the cart, especially when going up or down ramps and over bumps. Leave the straps/banding on until the oven is near the assembly area.



- Make sure that the notch on tube of the winch assembly is aligned with the pin in the tripod base. These alignments are important and keep the jack aligned properly.
- Check for smooth operation. The cable should not be pinched and should pass smoothly over the pulley on top of the pole assembly.
- Inspect cable prior to each use.
- If cable is frayed or shows signs of excessive wear and tear, DO NOT USE until cable is replaced.
- At a minimum replace the cable annually with wire rope that meets or exceeds the jack manufacturer's specifications.
- Do not exceed the stated capacity of the jack.



Failure to engage the Lifting Jacks into the Lifting Pipe properly and completely will result in damage, injury, or death from a falling hood.



- Both jacks should be raised in unison, otherwise they may bind and a dangerous situation will develop.
- Do not put any part of yourself under the hood at any time.
- The hood is heavy. Be careful.

Lifting Jack Setup

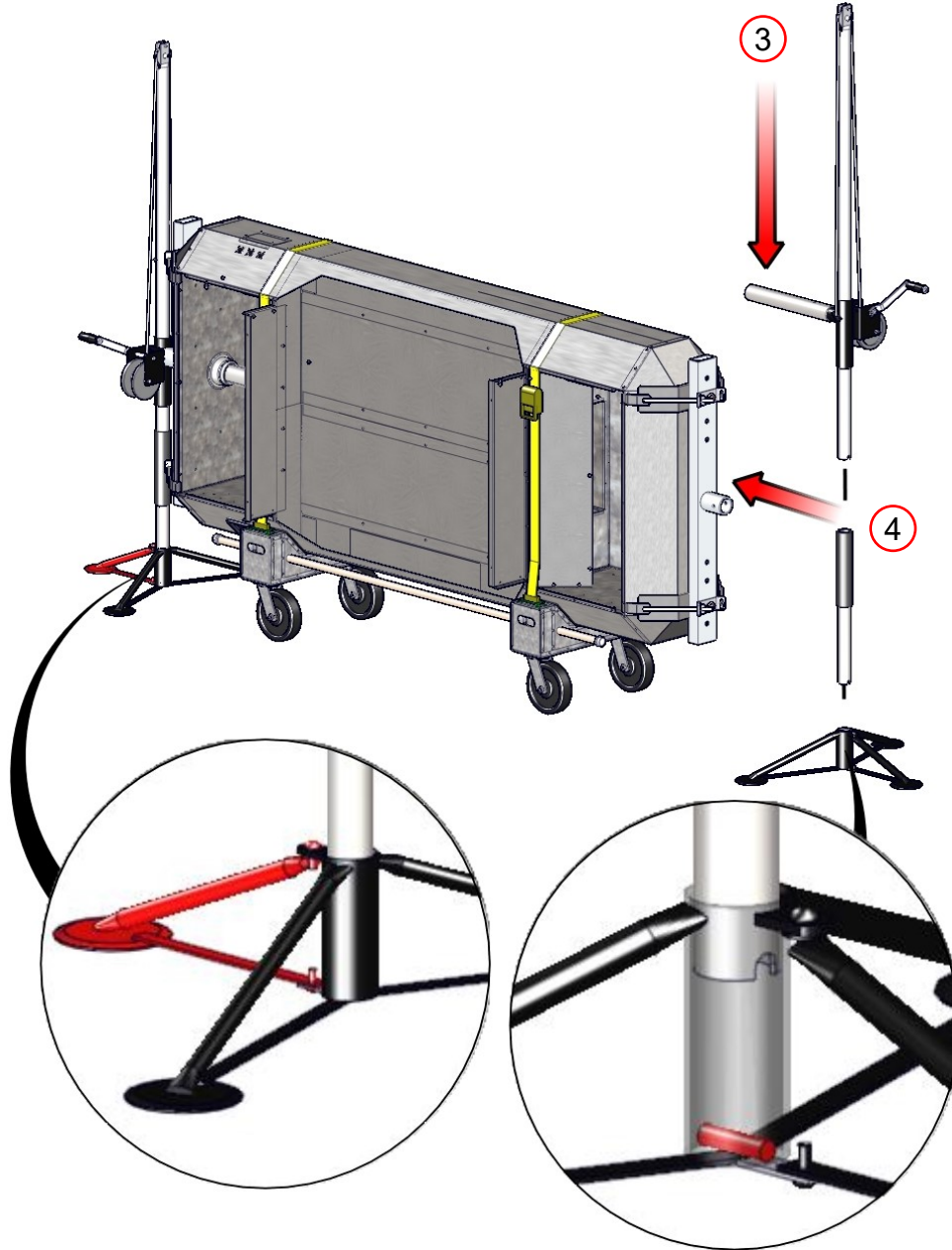

The folding leg of the tripod must be positioned outwards from the hood.

Stacking Hood on the Ovens



DANGER

- Both jacks should be raised in unison, otherwise they may bind and a dangerous situation will develop.
- Do not put any part of yourself under the hood at any time.
- The hood is top heavy. Be careful.

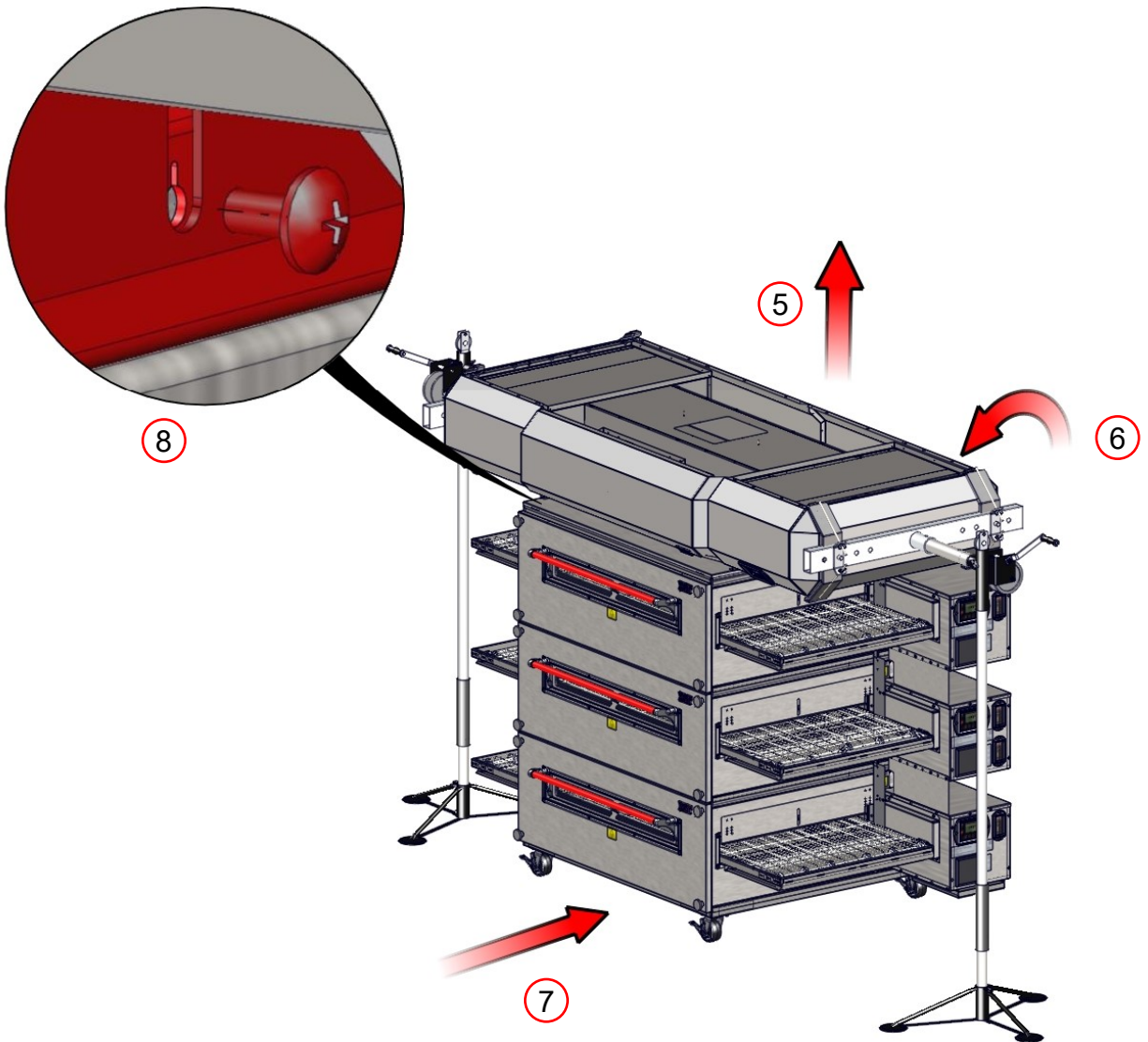

Hang Hood From Ceiling Joists



Hood Must Be Suspended From Ceiling Joists.

All thread provided by others

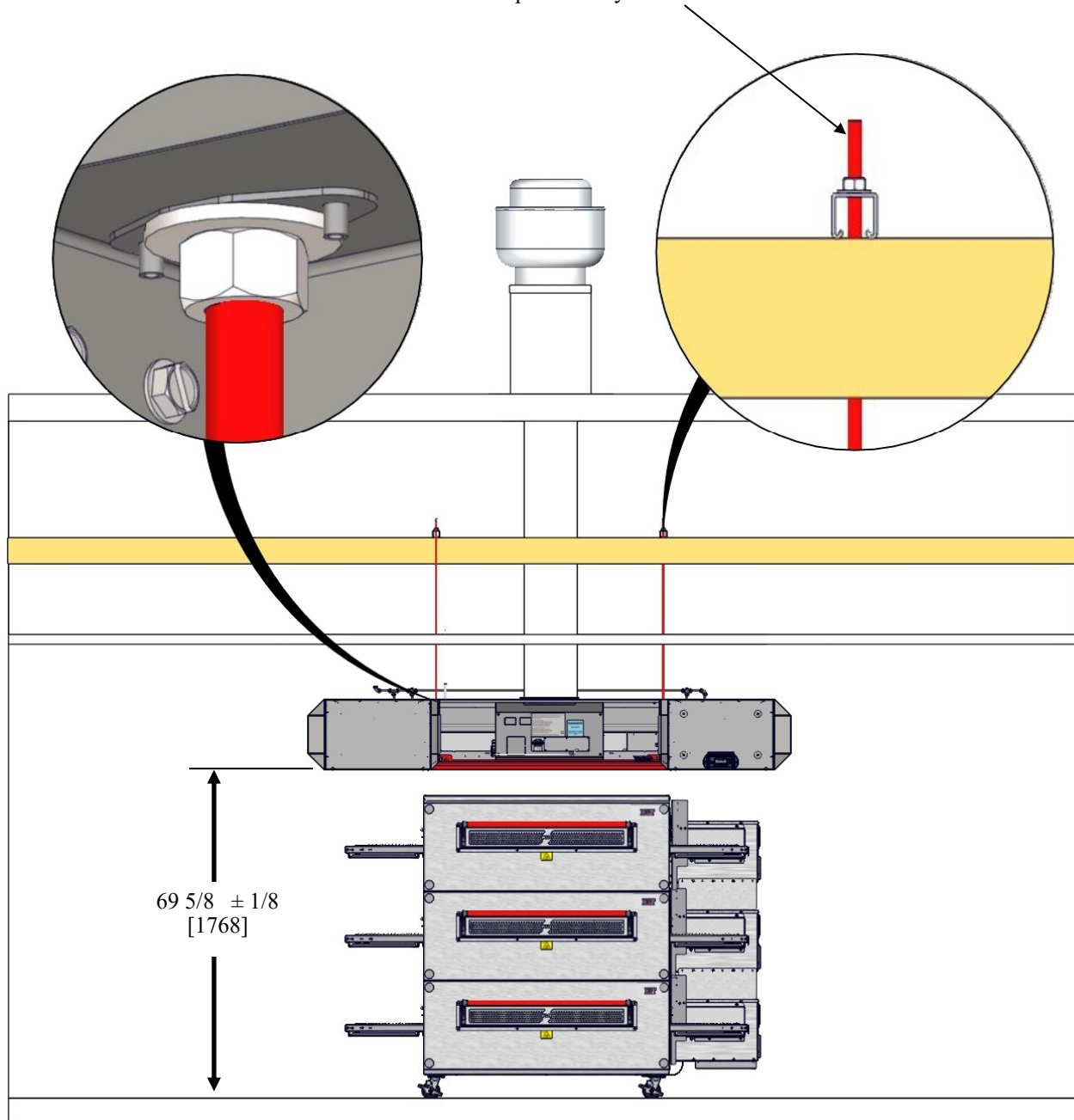

This measurement is from the **finished** floor to the bottom of the suspended hood.

NOTE: All dimensions in inches [millimeters], ± 1/4 [6], unless otherwise noted.

Install Grease Trays, Covers, and Grease Filters

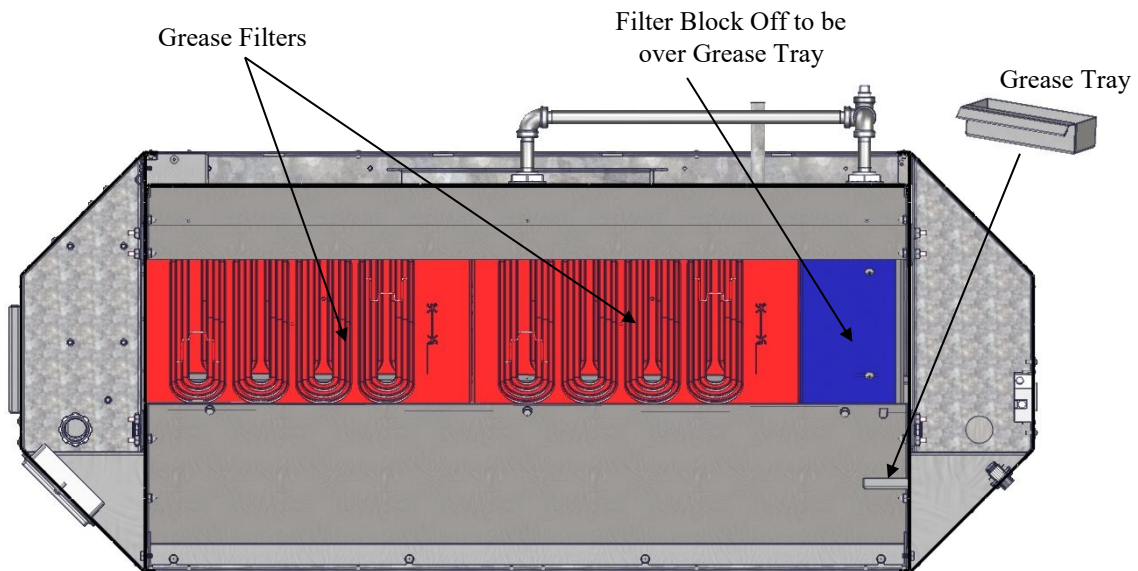
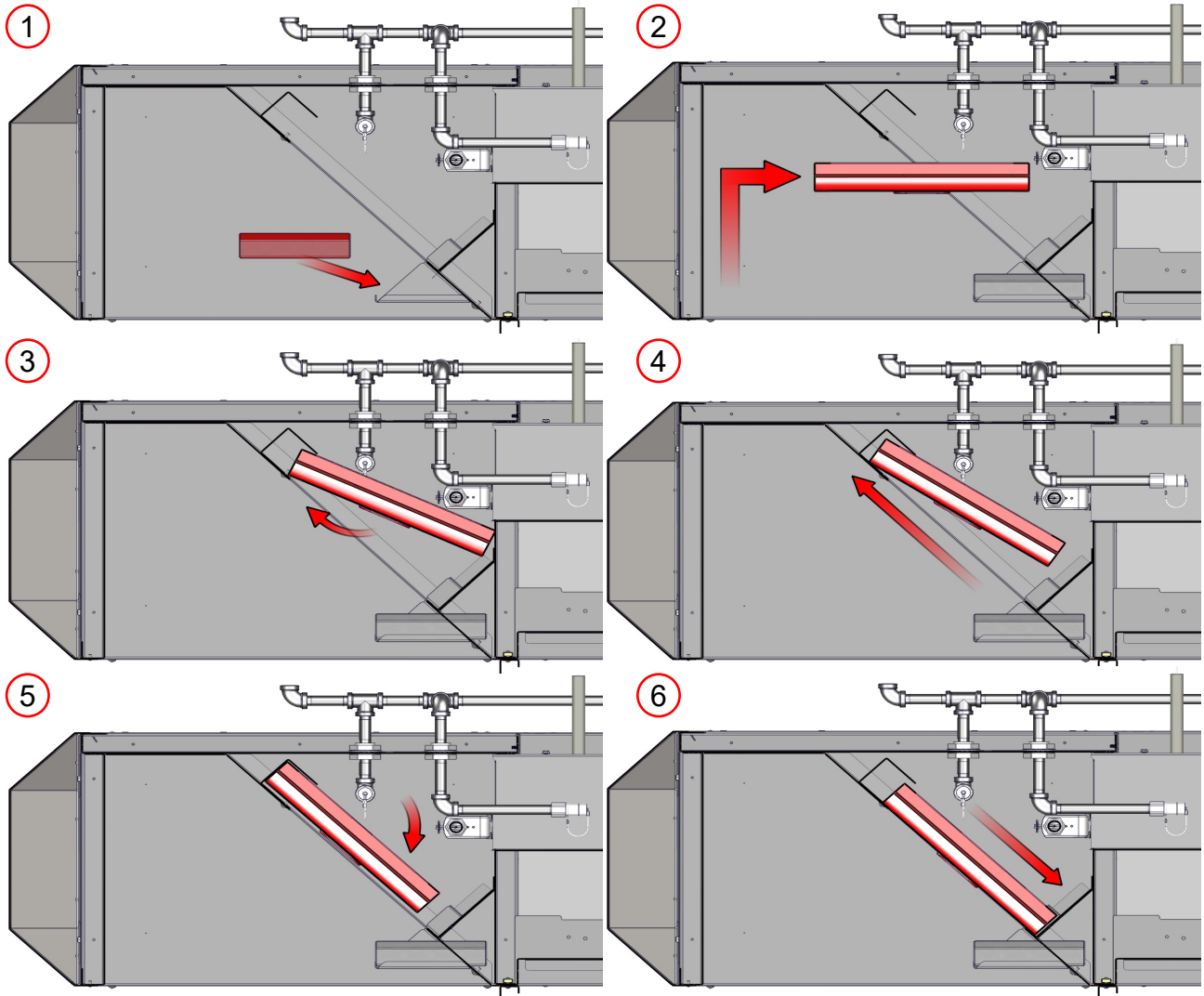

F Hood Shroud Work Instruction

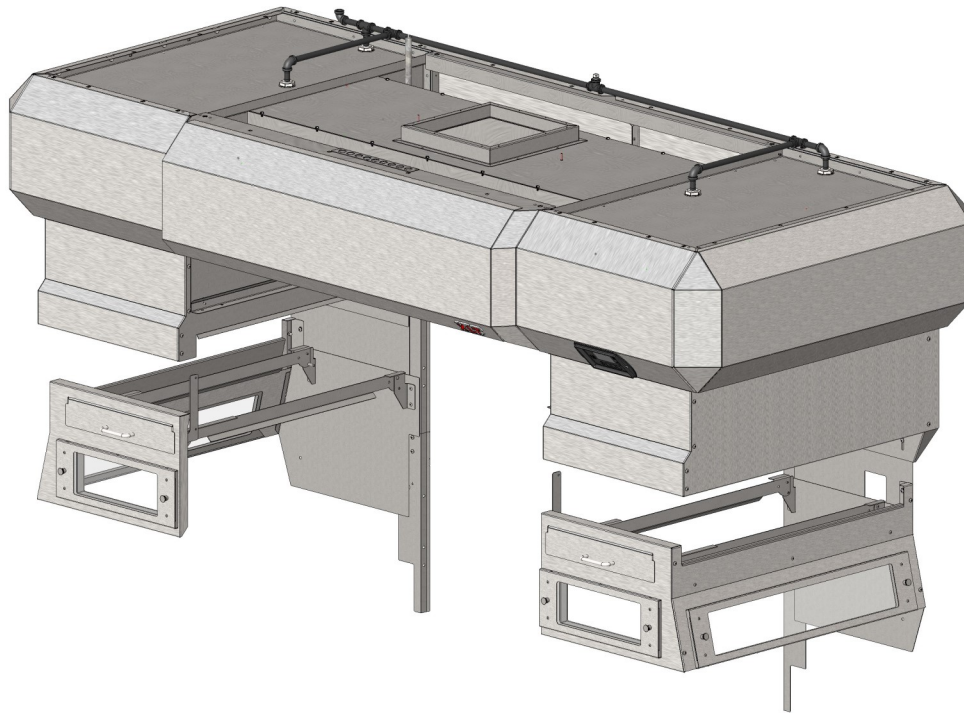



Scan To Watch The Video Instruction



Or Visit:

xltovens.com/f2-shrouds

Tool Requirements	
Screwdriver: Phillips #2	
3/8" (10mm) Wrench	

Shroud Boxes		
Box Labels	Double Stack	Triple Stack
	Qty	Qty
RH Upper Shroud Box	1	1
LH Upper Shroud Box	1	
RH Lower Shroud Box	1	2
LH Lower Shroud Box	1	2
Accessories Box	1	1

Install Hood Relocation Cord Assembly

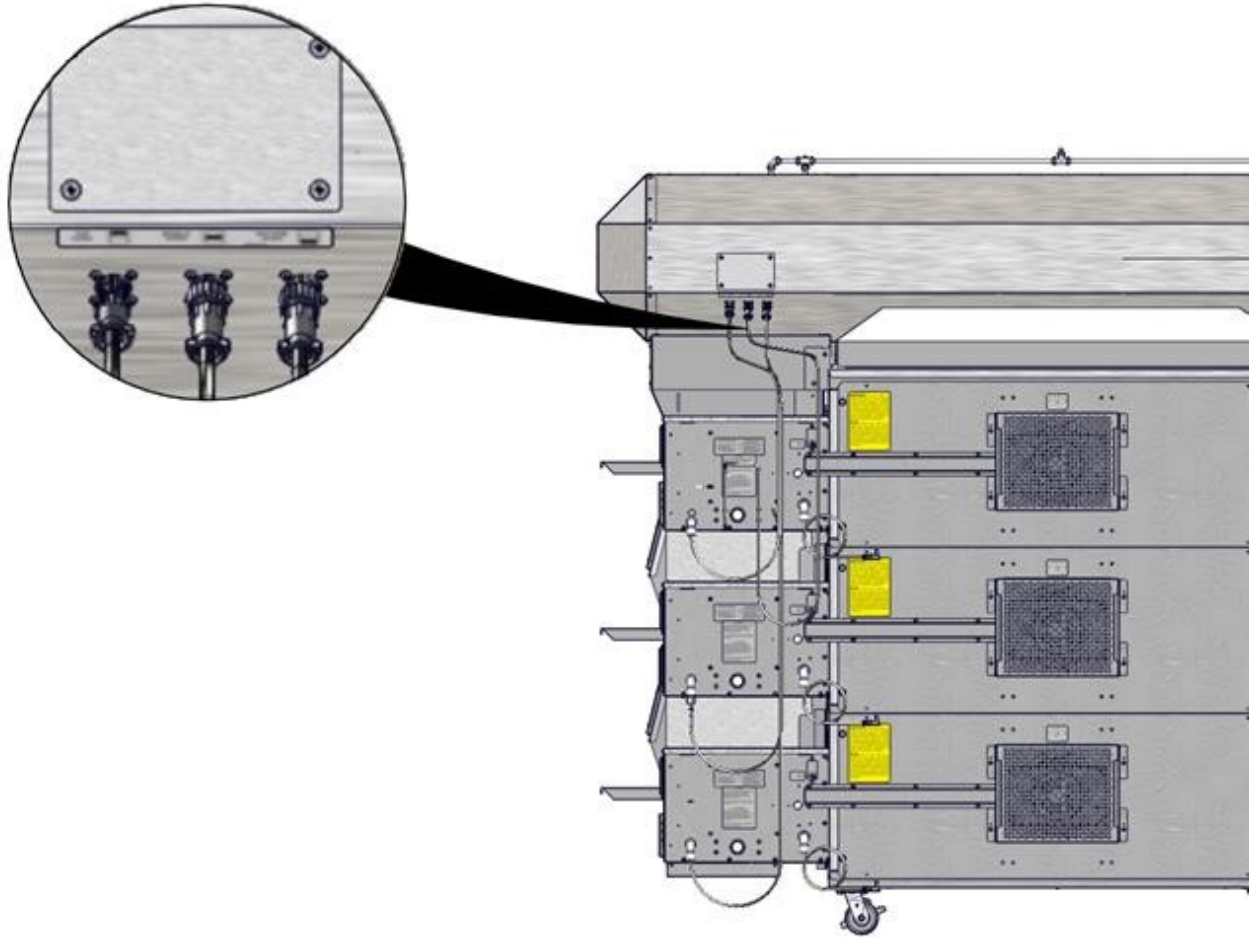

All hoods are outfitted with three (3) switch relocation receptacles, regardless of how many XLT ovens are installed.

For a single oven use “Top” location.

For a double stack use “Top” location for upper oven and “Bottom” location for lower oven, leaving “Middle” location open.

Insert and lock each oven control cord into the designated location on the bottom of the hood control box.

Connect Hood Relocation Cord Assembly

1

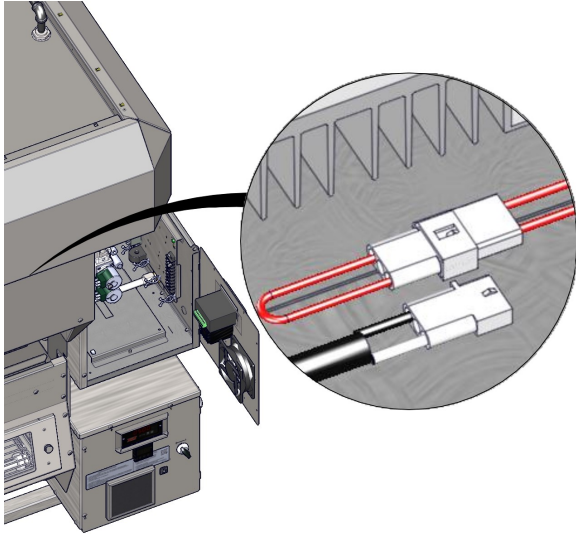

2

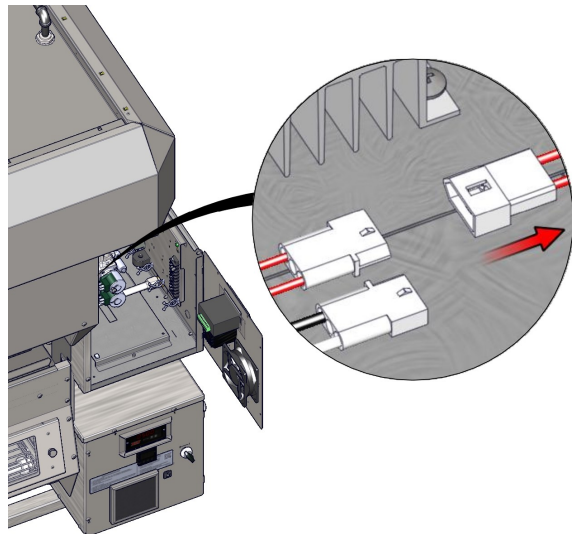

3

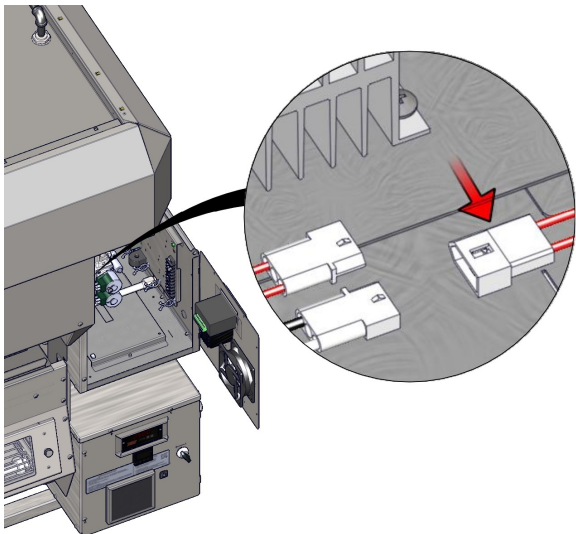

4

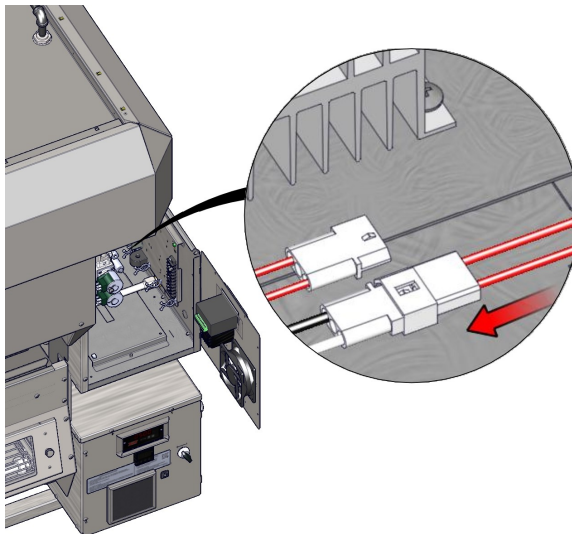

This page is intentionally left blank.

Variable Frequency Drive Adjustments

All XLT Hoods are functionally tested at the factory. Operation is verified, and adjustments are made to ensure proper operation. However, field conditions are sometimes different than factory conditions. **It is necessary to have an authorized service technician verify operation and make field adjustments if needed.**

The following items must be checked and verified to meet the specifications and requirements stated in this manual prior to the hood being commissioned:

- Correct fan rotation
- Balanced make-up air

The Hood Initial Start-Up Checklist, found at the end of this manual, must be completed at time of installation, signed by the Customer and returned to XLT and the Authorized Distributor to initiate Warranty Policy. **If the Start-Up Checklist is not filled out completely and returned to XLT, the Warranty will not be honored.**

The VFD controller is adjusted at the factory to the values displayed in the chart below.

VFD Controller Settings							
	Ovens On			1832, 2336 & 2440	3240, 3250DS & 3255	3855	4455
	Top	Middle	Bottom				
Single	X			20 Hz	25 Hz	30 Hz	30 Hz
	X			20 Hz	25 Hz	30 Hz	30 Hz
Double			X	20 Hz	30 Hz	35 Hz	45 Hz
	X		X	20 Hz	30 Hz	35 Hz	45 Hz
Triple	X			20 Hz	25 Hz	30 Hz	30 Hz
		X		20 Hz	30 Hz	35 Hz	45 Hz
			X	30 Hz	35 Hz	40 Hz	50 Hz
	X	X		20 Hz	30 Hz	35 Hz	45 Hz
	X		X	30 Hz	35 Hz	40 Hz	50 Hz
		X	X	30 Hz	35 Hz	40 Hz	50 Hz
	X	X	X	30 Hz	35 Hz	40 Hz	50 Hz
Fire Suppression				60 Hz DO NOT CHANGE			

If you require either more or less air flow, follow these steps: (Reference Hood User Interface image on next page)

1. Press and hold the LIGHTS and XLT LOGO buttons to enter into factory tech mode.
2. Use the Up/Down arrows to reach manual air balance.
3. Press and hold ENTER button for three (3) seconds. Entire row will flash.
4. Scroll to desired oven setting. Press ENTER.
5. +/- should flash and it allows +/- change up to 10 Hz.
6. Press ENTER to save changes.
7. Press ON to test air balance.

Initial Start Up

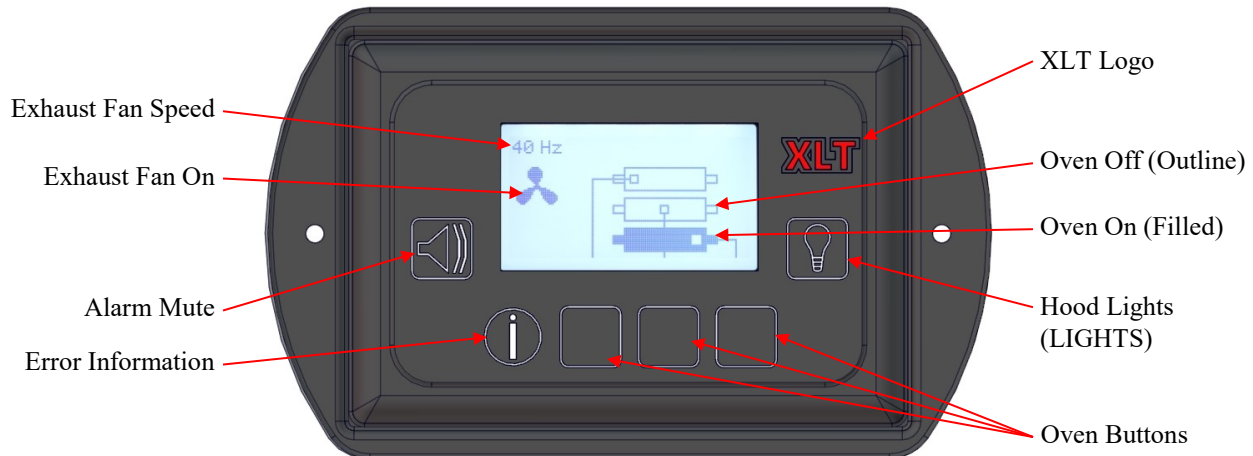

NOTE

When XLT ovens are outfitted with an XLT hood and the receptacles are plugged into the hood instead of the wall, the main power button of the oven is disabled and no longer operates. The Hood User Interface (HUI) on the XLT hood overrides the oven power button.

Hood Operation

1. Turn the desired oven(s) on by pressing the corresponding oven button. Refer to the Oven Operation section for instructions on how to adjust temperature and conveyor speed. The oven(s), exhaust fan, and make-up air unit will be activated by this switch if the XLT hood is installed according to this manual.
2. When additional ovens are turned on, via the HUI the VFD will automatically increase the exhaust fan speed.
3. When shutting down the ovens, turn the desired oven off by pressing the corresponding button on the HUI. The make-up air unit will shut off. The exhaust fan will shut off after about fifteen (15) minutes and the oven will shut off after about thirty (30) minutes.

Resetting Hood Cooling Fan and Grease Timer

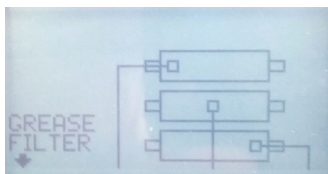

1. The Cooling Fan and Grease Filter reset alarm will show up in the lower left hand side of the Hood User Interface. Press the Error Information button to enter reset screen.



2. To reset the Cooling Fan or Grease Filter press the center capacitive touch button with reset above it to set the time back to zero (0).



3. The following screen will show for five (5) seconds and then return to the normal operating screen.

The optional valance kit size is determined by XLT hood size and distance from the finished floor to the installed drop ceiling height. The valance kit screws directly to the XLT hood and does not require any structural support. The plastic coating must be removed from all parts prior to installation.

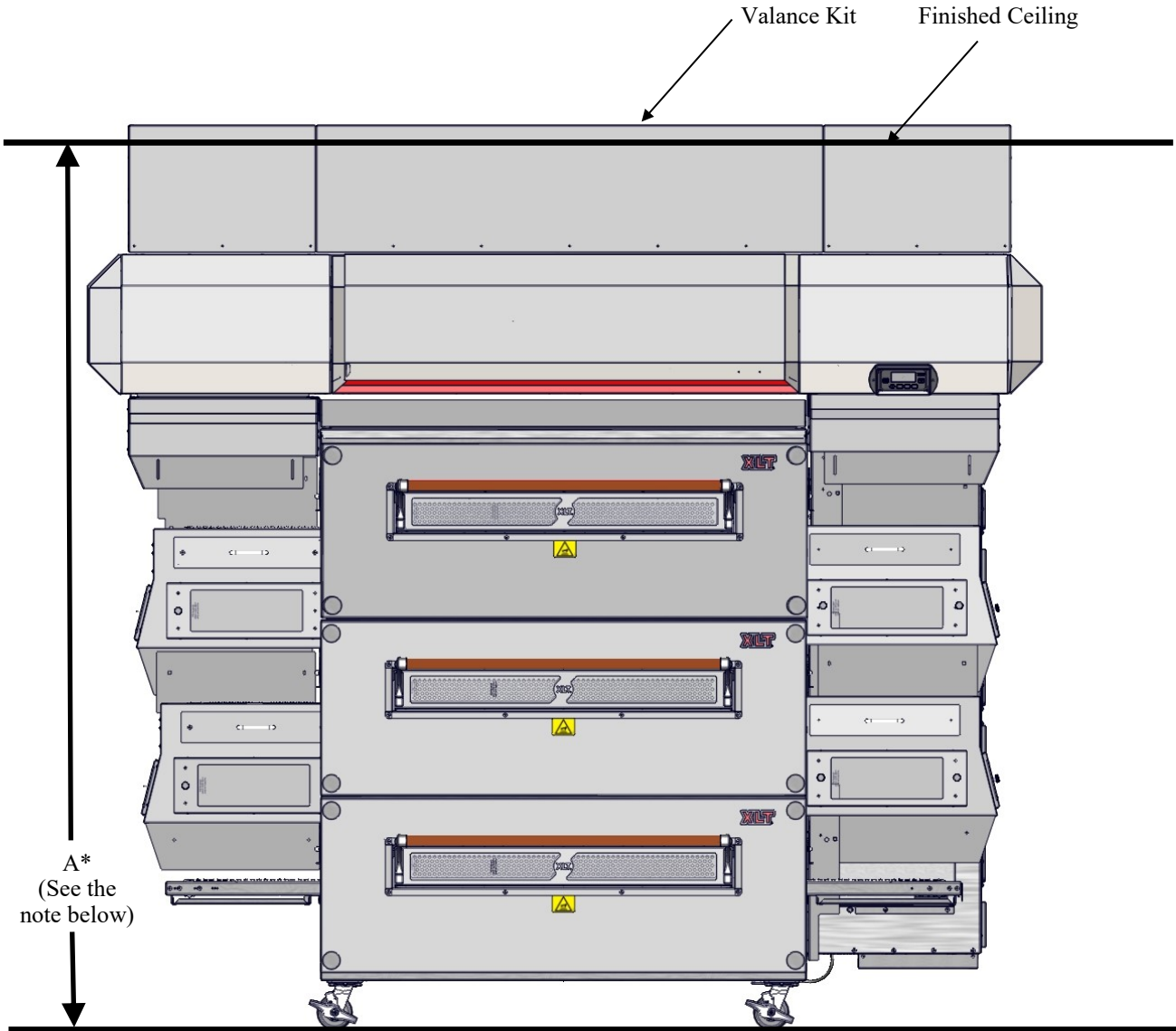

The measurement A* above is from the **finished** floor to the bottom of the suspended ceiling. XLT hood valance kits are available for different floor to ceiling heights. To get the correct size of valance, contact XLT or your designated representative for more information.

Install Valance Brackets

①

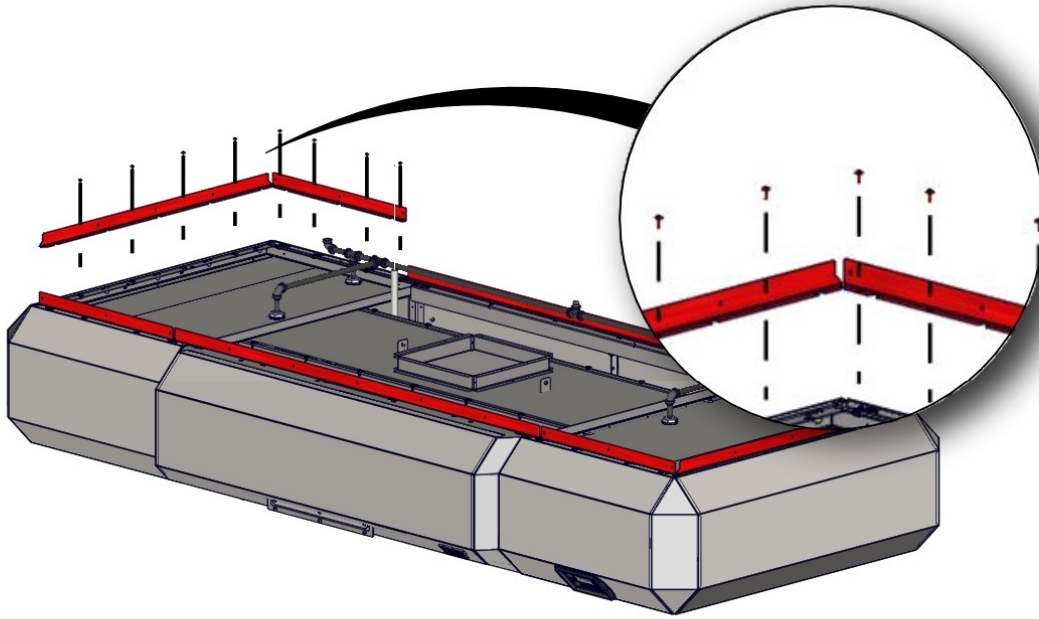

Install Front and Back Panels

②

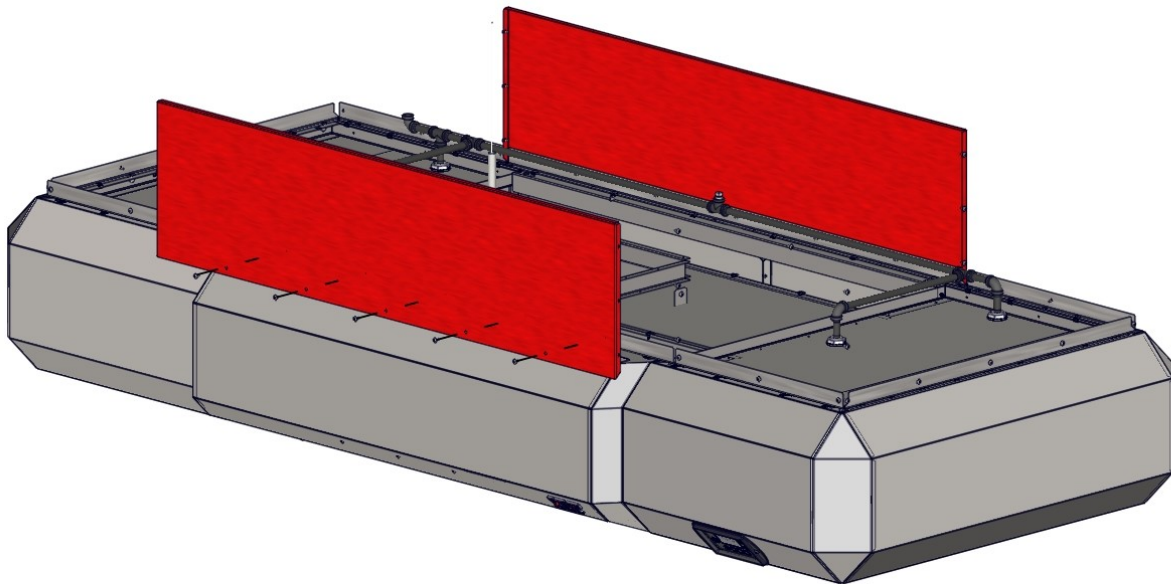

Install Corner Panels

3

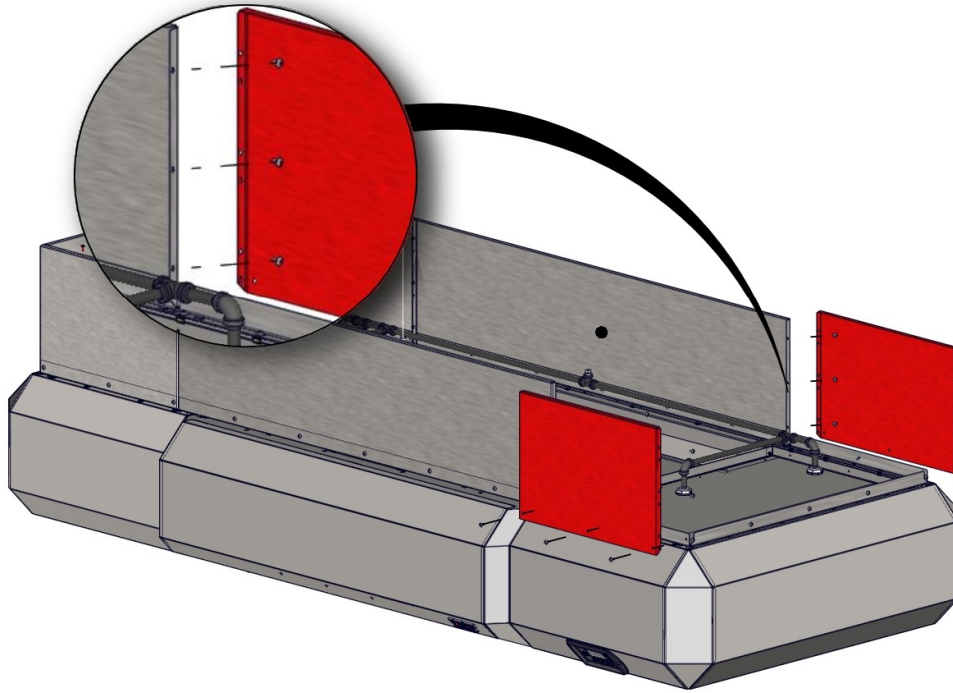

Install End Panels

4

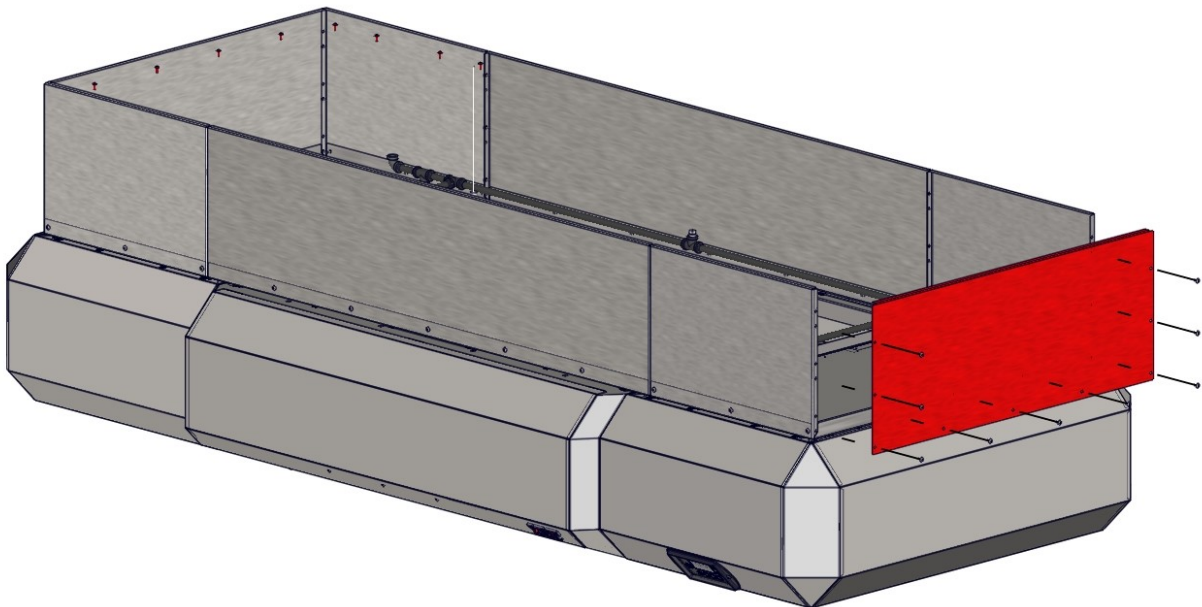

Optional Hood Duct Wrap

Install Duct Wrap Brackets

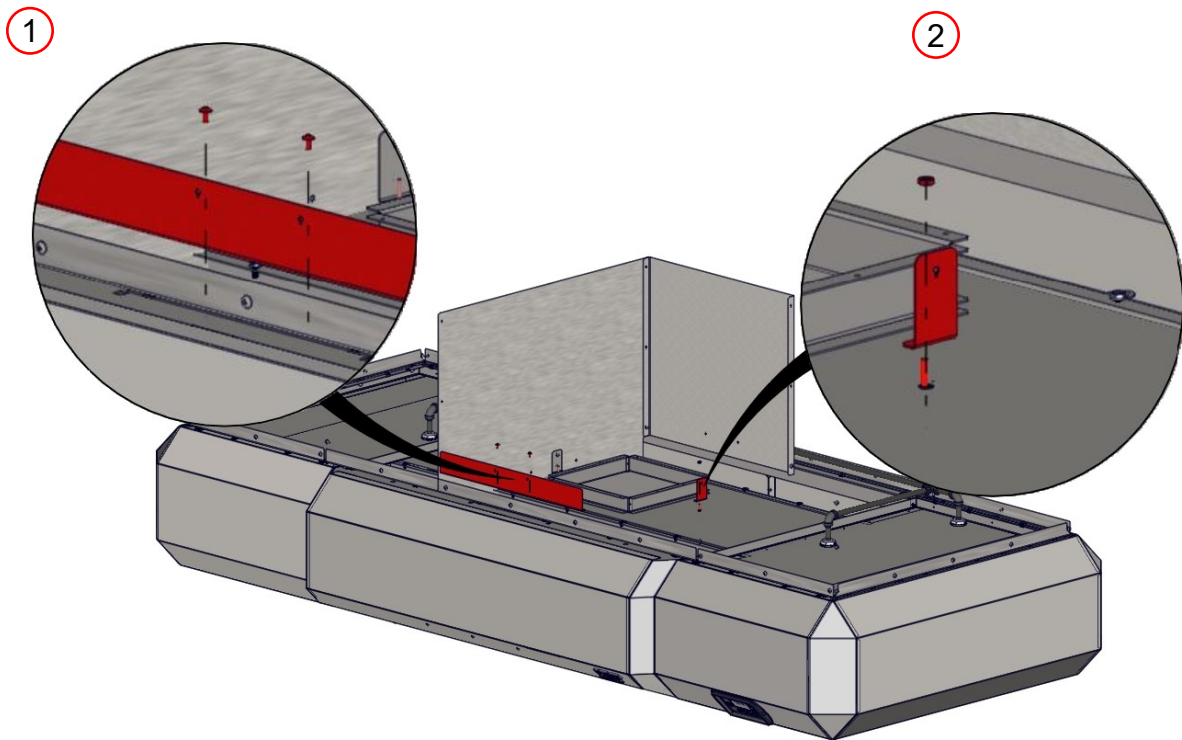

Install Duct Wrap Panels

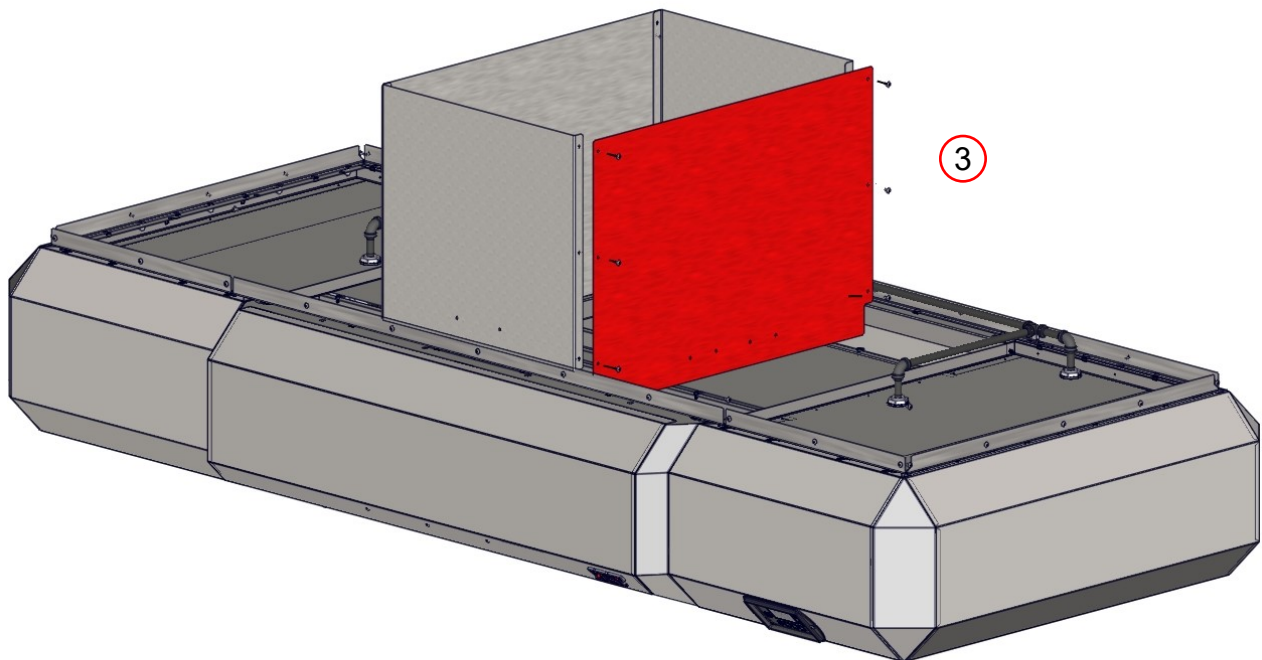

As with any appliance, periodic maintenance is required. Many factors affect this schedule such as product mix and hours of usage. An example schedule is included.

Your XLT hood is constructed of stainless and aluminized steel. Check application restrictions on product label prior to usage. Observe recommended precautionary and safety measures as dictated by the product manufacturer. Bleach can cause stainless steel to discolor and corrode and is not recommended for cleaning.

Do not use abrasive or caustic cleaners. Abrasive pads will scratch stainless steel surfaces. Areas with heavy buildup should be sprayed and allowed to soak for up to five (5) minutes prior to wiping clean. Always wipe with the “grain” of the surface to maintain appearance.



Oven must be cool and the electric cord unplugged before any cleaning is done.



Shroud Panels can weigh up to 50 lbs [23 kg]. Use caution when lifting.



DO NOT spray liquid cleaning agents in the hood electrical box (located on front of upper portion), or the Large User Interface (Located on front lower right corner).

Hood Cleaning & Maintenance Schedule				
	Daily	Weekly	Monthly	As Required
Cleaning				
Wipe down Front, Sides, & Top	<input type="checkbox"/>			
Empty & Clean Grease Trays	<input type="checkbox"/>			<input type="checkbox"/>
Clean Fan Filter	<input type="checkbox"/>			
Clean Grease Filters		<input type="checkbox"/>		<input type="checkbox"/>
Clean Duct and Exhaust Fan			<input type="checkbox"/>	<input type="checkbox"/>
Clean Glass Windows		<input type="checkbox"/>		<input type="checkbox"/>
Replace				
Fan Filter(s)				<input type="checkbox"/>
Light Bulbs				<input type="checkbox"/>

 **NOTE** Glass windows can be cleaned with simple window cleaner. XLT prefers that the glass windows be cleaned in place, however, they are designed with removable knobs in the event that there is a need to wash in a compartment sink.

1

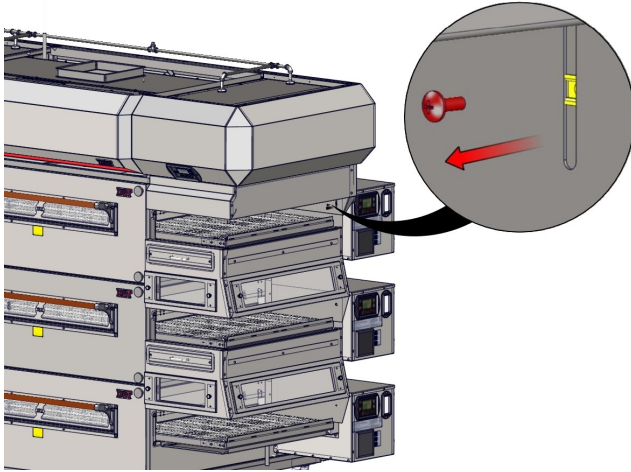

Remove fastener from back of upper shroud, on both sides of the hood.

2

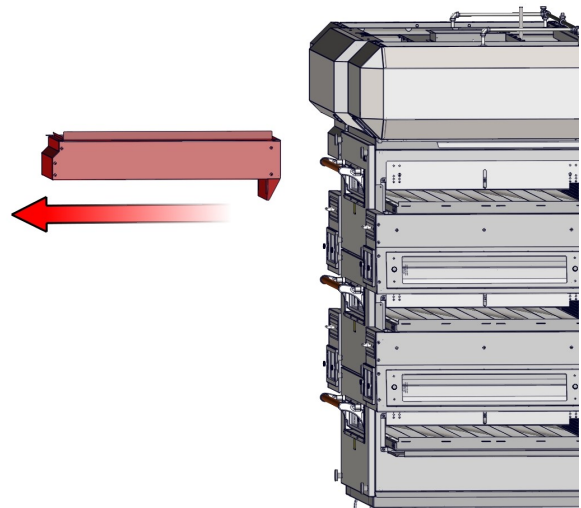

Remove the upper shrouds from both sides of the hood.

3

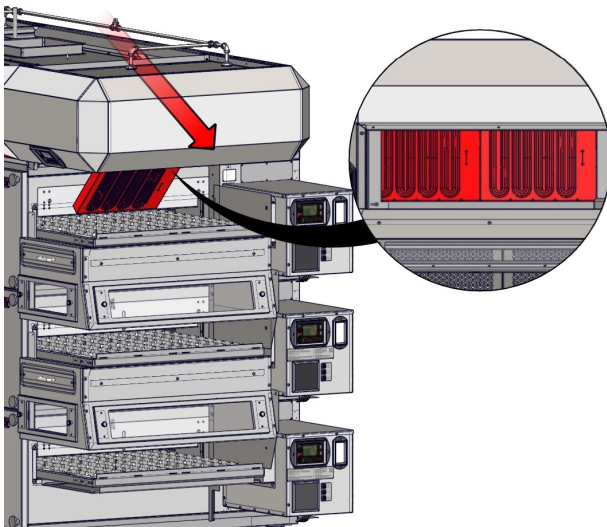

Remove the grease filters from both sides of the hood. Refer to the page of hood and shroud assembly/Install Grease Trays, Covers, and Grease Filters, and reverse the process.

4

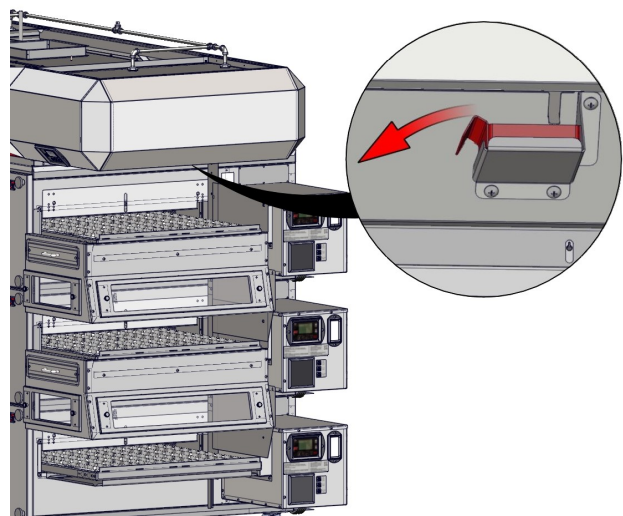

Remove the grease tray from both sides of the hood.

This page is intentionally left blank.

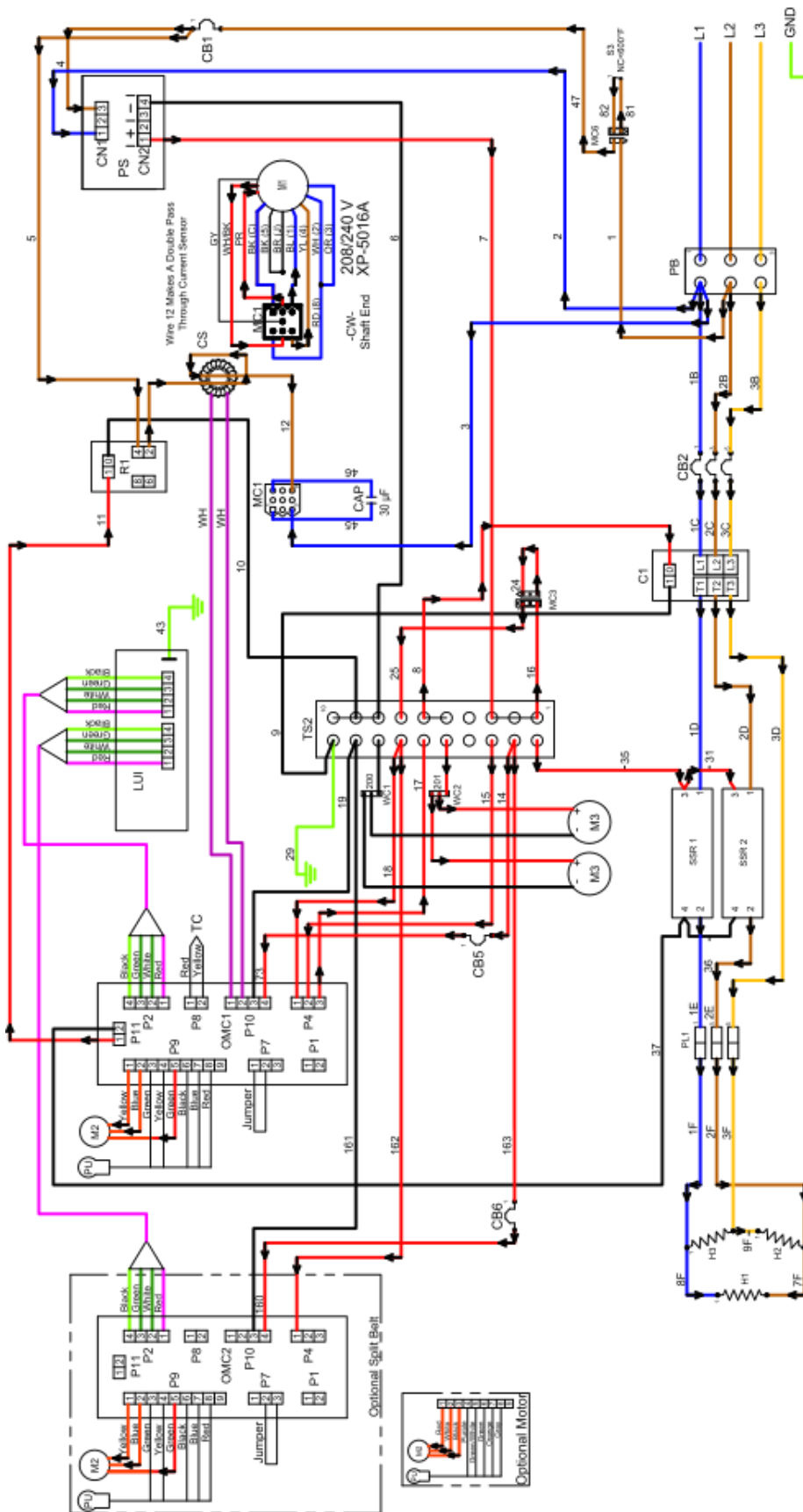

VOLTAGE COLOR KEY:

- 240VDC+ (Red)
- 240VDC- (Blue)
- 5VDC (Green)
- 208/240VAC(L1) (Yellow)
- 208/240VAC(L2) (Orange)
- 208/240VAC(L3) (Purple)
- 485+V485- (Light Green)
- Ground (Light Blue)
- Analog Volts (Light Blue)

X3H-1832
X3H-2336

208/240 VAC 3 PH 60 HZ
XD-9130H02-208/240-5300-3 LH
LH Controls Left Side
10/4/2022

- R1 Oven Fan Motor Relay
- S3 Switch, High Limit
- SSR1 Solid State Relay, 90 Amp
- SSR2 Solid State Relay, 90 Amp
- TC Thermocouple
- TS2 Terminal Strip
- WC1 Wago Connector
- WC2 Wago Connector

- M1 Motor, Oven Fan
- M2 Motor, Conveyor
- M3 Motor, Cooling Fan
- OMC1 Oven Machine Control, Main
- OMC2 Oven Machine Control, Split Belt
- PB Power Block
- PL1 Push Lock, 1-3 Elements
- PS Power Supply
- PU Pick-Up

- C1 Contactor, 70 Amp
- CAP Capacitor 30µF
- CB1 Circuit Breaker, 7 Amp, Main
- CB2 Circuit Breaker, 63 Amp, Heating Elements
- CB5 Circuit Breaker, 1/2 Amp, Conveyor Motor
- CB6 Circuit Breaker, 1/2 Amp, Conveyor Motor
- CS Current Sensor
- H1-H3 Heating Element, 208 or 240 VAC, 5300 W
- LUI Large User Interface

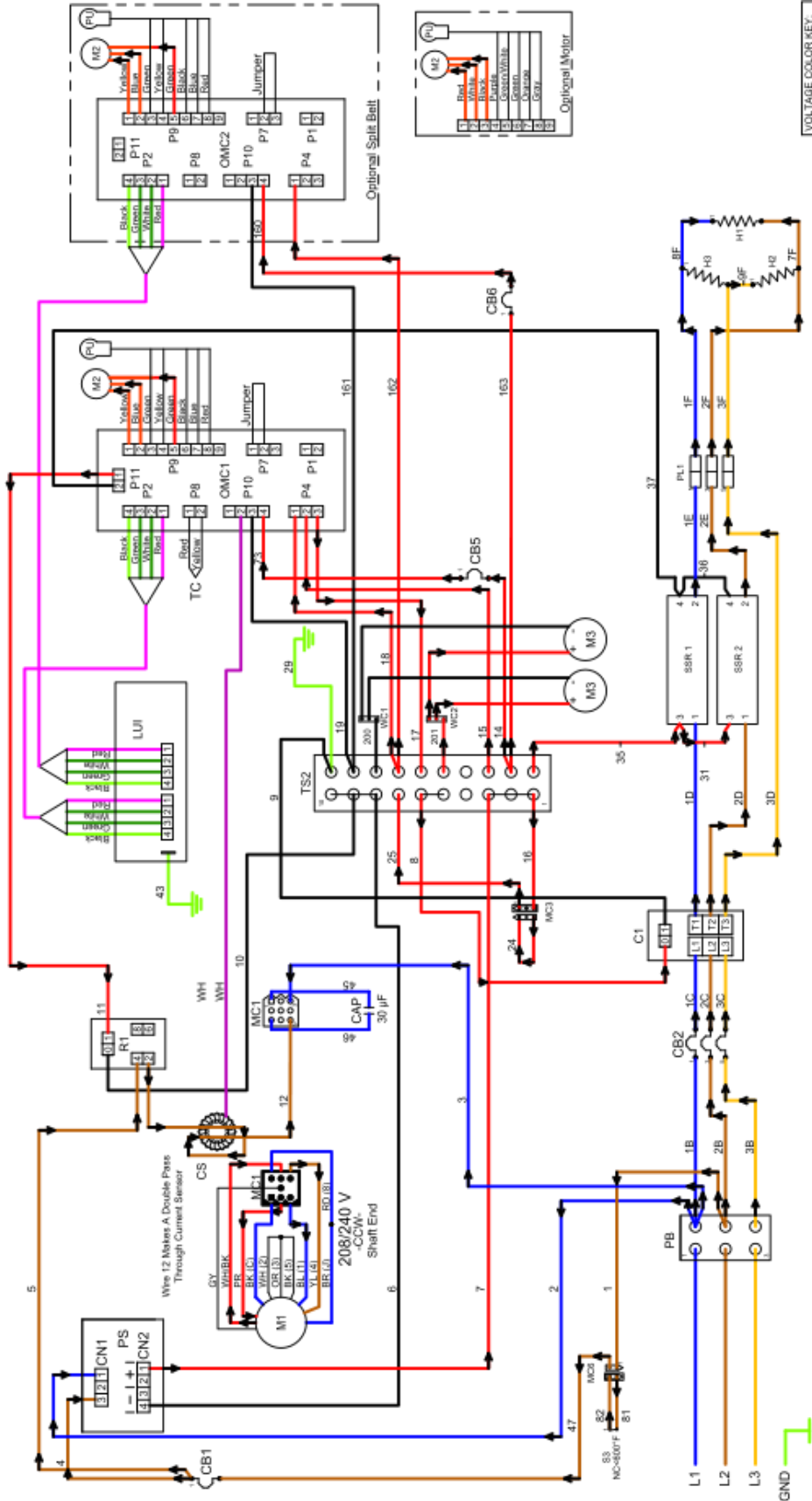

VOLTAGE COLOR KEY:

Red	240VAC
Black	208/240VAC(L1)
Blue	208/240VAC(L2)
Yellow	208/240VAC(L3)
Green	485V-HRS
White	Ground
Grey	Analog Volts

X3H-1832
X3H-2336

208/240 VAC 3 PH 60 HZ
XD-9130H02-208/240-5300-3 RH
RH Controls Right Side
10/4/2022

- C1 Contactor, 70 Amp
- CAP Capacitor 30µF
- CB1 Circuit Breaker, 7 Amp, Main
- CB2 Circuit Breaker, 63 Amp, Heating Elements
- CB5 Circuit Breaker, 1/2 Amp, Conveyor Motor
- CB6 Circuit Breaker, 1/2 Amp, Conveyor Motor
- CS Current Sensor
- H1-H3 Heating Element, 208 or 240 VAC, 5300 W
- LUI Large User Interface
- M1 Contactor, 70 Amp
- M2 Motor, Oven Fan
- M3 Motor, Cooling Fan
- OMC1 Oven Machine Control, Main
- OMC2 Oven Machine Control, Split Belt
- PB Power Block
- PL1 Push Lock, 1-3 Elements
- PS Power Supply
- PU Pick-Up
- R1 Oven Fan Motor Relay
- S3 Switch, High Limit
- SSR1 Solid State Relay, 90 Amp
- SSR2 Solid State Relay, 90 Amp
- TC Thermocouple
- TS2 Terminal Strip
- WC1 Wago Connector
- WC2 Wago Connector

[Reference Wire Numbers; Wire Colors Subject To Change Without Notice]

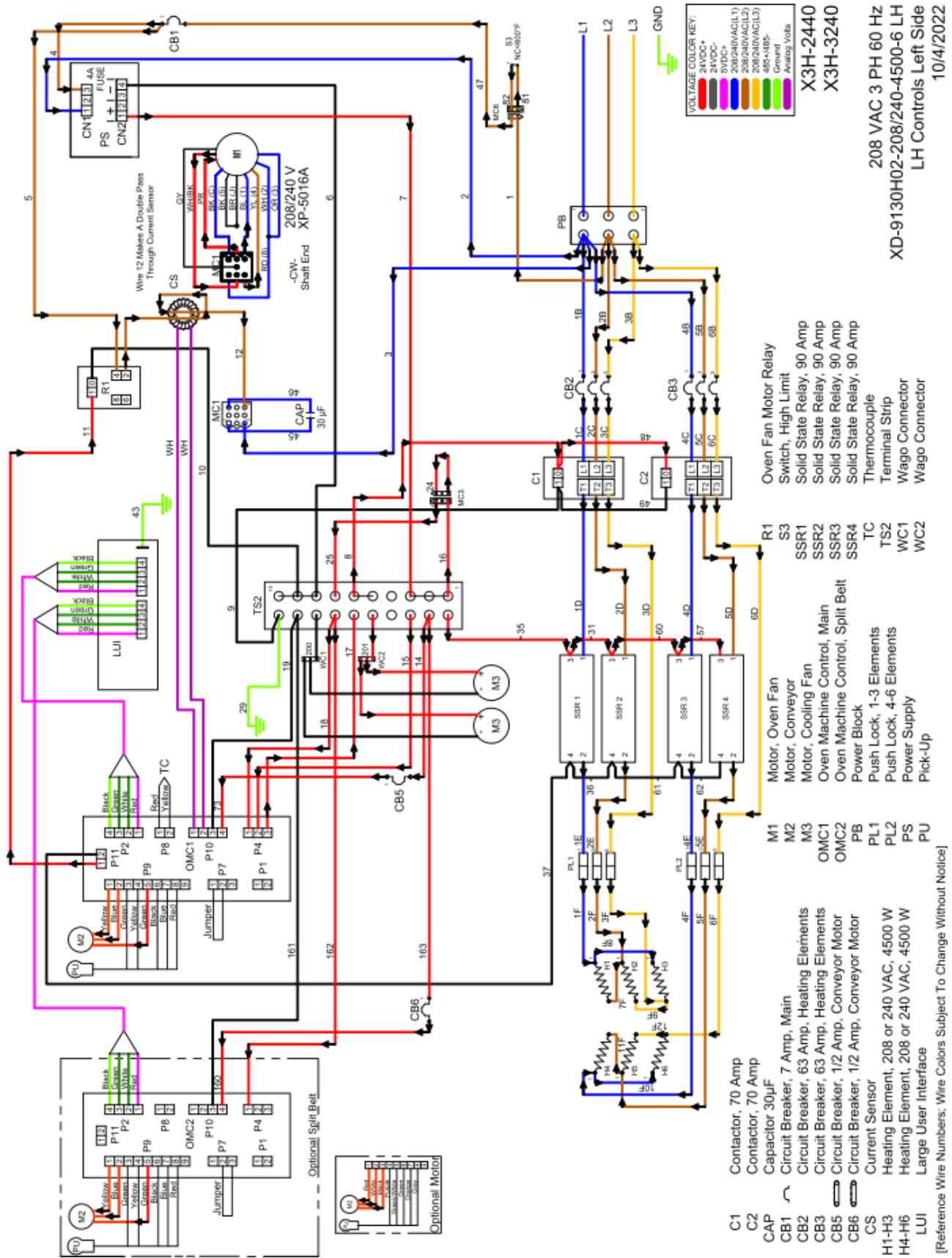

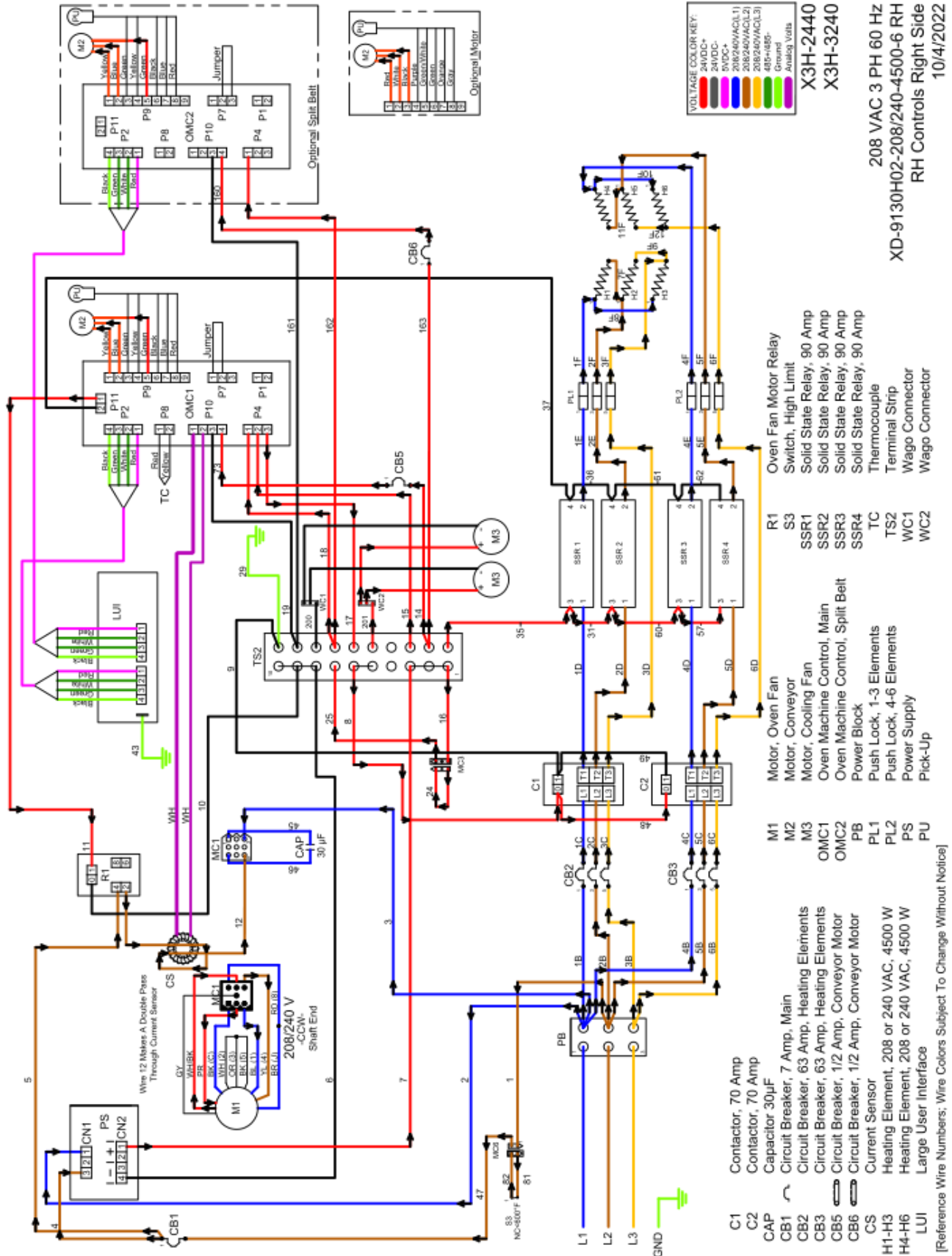

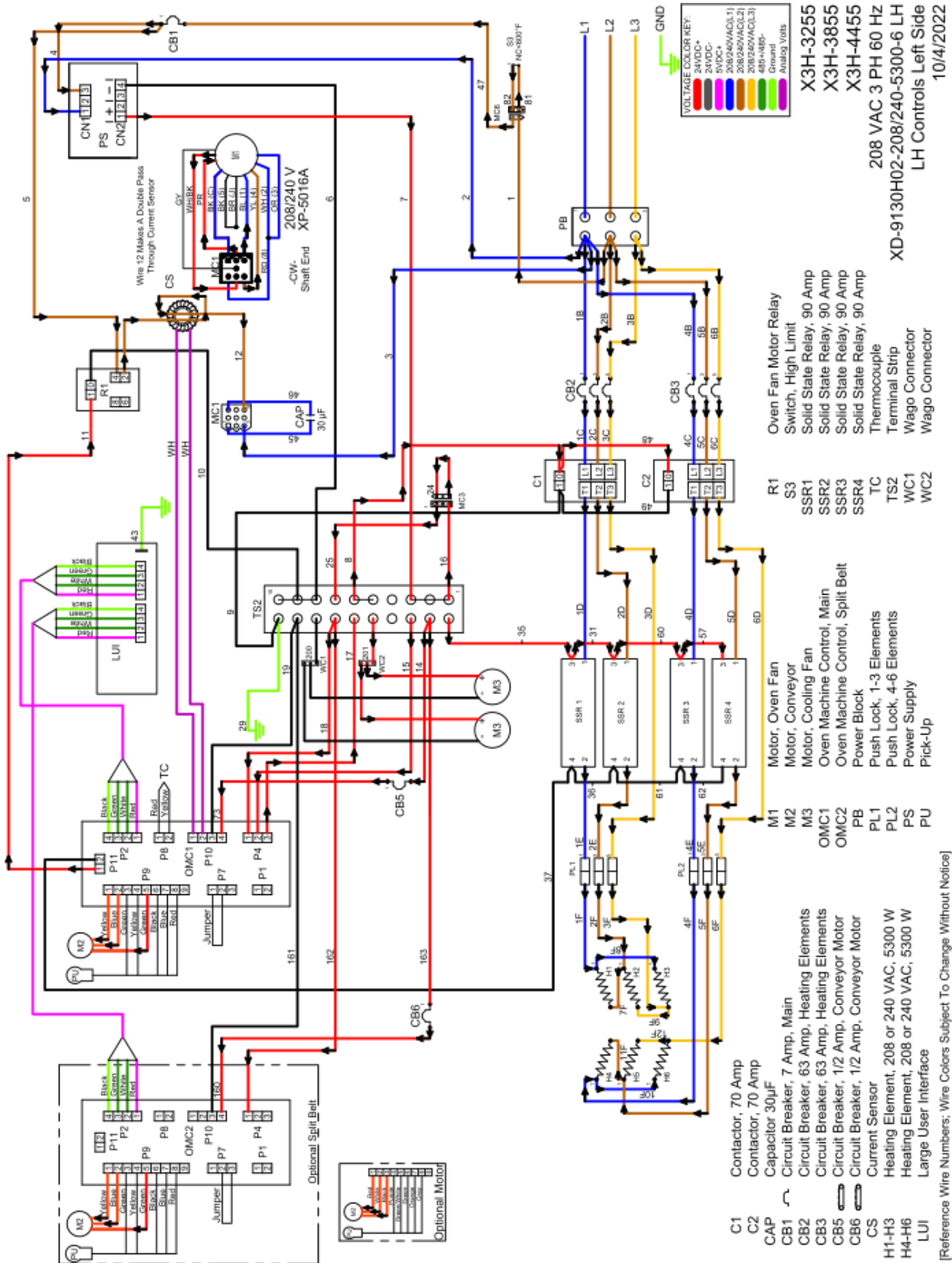

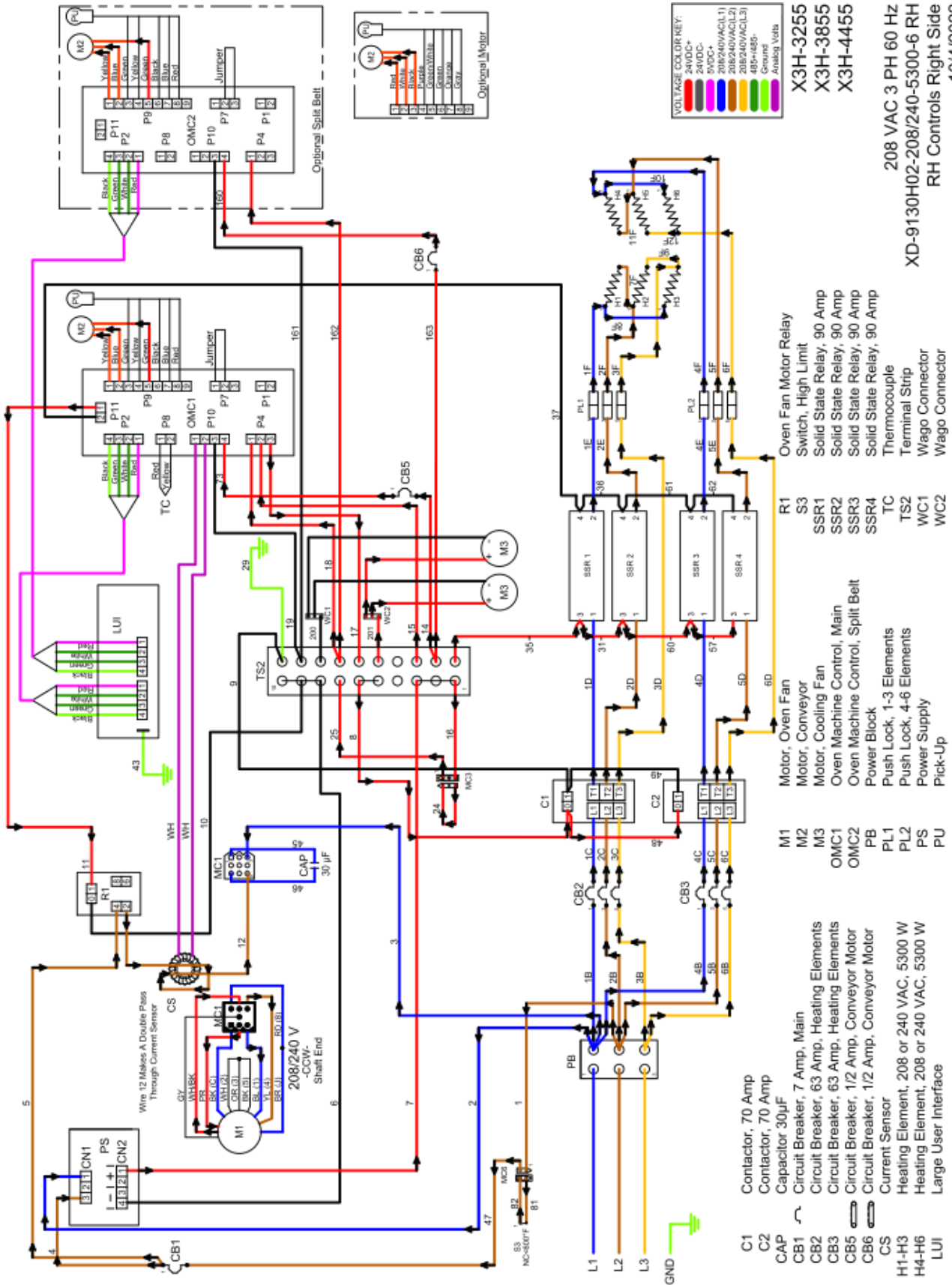

X3H-3255
X3H-3855
X3H-4455

208 VAC 3 PH 60 Hz
XD-9130H02-208/240-5300-6 RH
RH Controls Right Side
10/4/2022

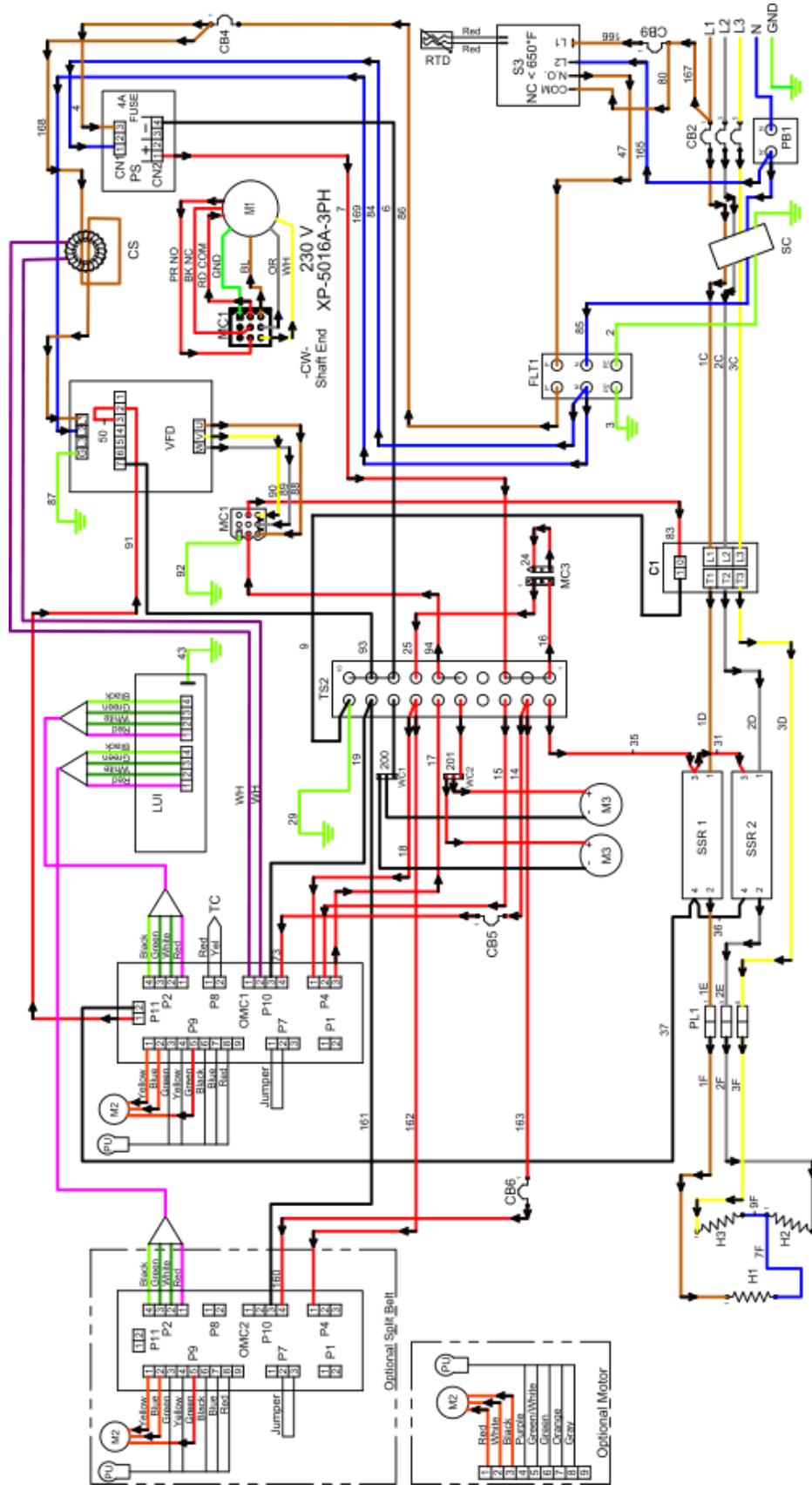

VOLTAGE COLOR KEY:

Red	240VDC+
Orange	50VDC
Yellow	380VAC(L1)
Green	380VAC(L2)
Blue	380VAC(L3)
Purple	380VAC(N)
Black	485-485-
White	Ground
Grey	Analog Volts

X3H-1832
X3H-2336

- C1 Contactor, 70 Amp
- CB2 Circuit Breaker, 63 Amp, Heating Elements
- CB4 Circuit Breaker, 10 Amp, Main
- CB5 Circuit Breaker, 1/2 Amp, Conveyor Motor
- CB6 Circuit Breaker, 1/2 Amp, Conveyor Motor
- CB9 Circuit Breaker, 1/2 Amp, High Limit
- FLT1 Filter, Control Voltage
- H1-H3 Heating Element, 240 VAC, 5300 W
- LUI Large User Interface
- M1 Motor, Oven Fan
- M2 Contactor, 70 Amp
- M3 Circuit Breaker, 63 Amp, Heating Elements
- OMC1 Circuit Breaker, 10 Amp, Main
- OMC2 Circuit Breaker, 1/2 Amp, Conveyor Motor
- PB1 Circuit Breaker, 1/2 Amp, Conveyor Motor
- PL1 Circuit Breaker, 1/2 Amp, High Limit
- H1-H3 Heating Element, 240 VAC, 5300 W
- LUI Large User Interface
- M1 Motor, Oven Fan
- M2 Motor, Conveyor
- M3 Motor, Cooling Fan
- OMC1 Oven Machine Control, Main
- OMC2 Oven Machine Control, Split Belt
- PB1 Power Block
- PL1 Push Lock, 1-3 Elements
- PU Power Supply
- RTD, High Limit
- S3 Switch, High Limit
- SC Suppression Core
- SSR1 Solid State Relay, 75 Amp
- SSR2 Solid State Relay, 75 Amp
- TC Thermocouple
- TS2 Terminal Strip
- VFD Oven Fan Motor Frequency Drive
- WC1 Wago Connector
- WC2 Wago Connector

380/415 VAC 3 PH 50 HZ
XD-9130H02-380/415-5300-3
LH Controls Left Side
10/4/2022

[Reference Wire Numbers; Wire Colors Subject To Change Without Notice]



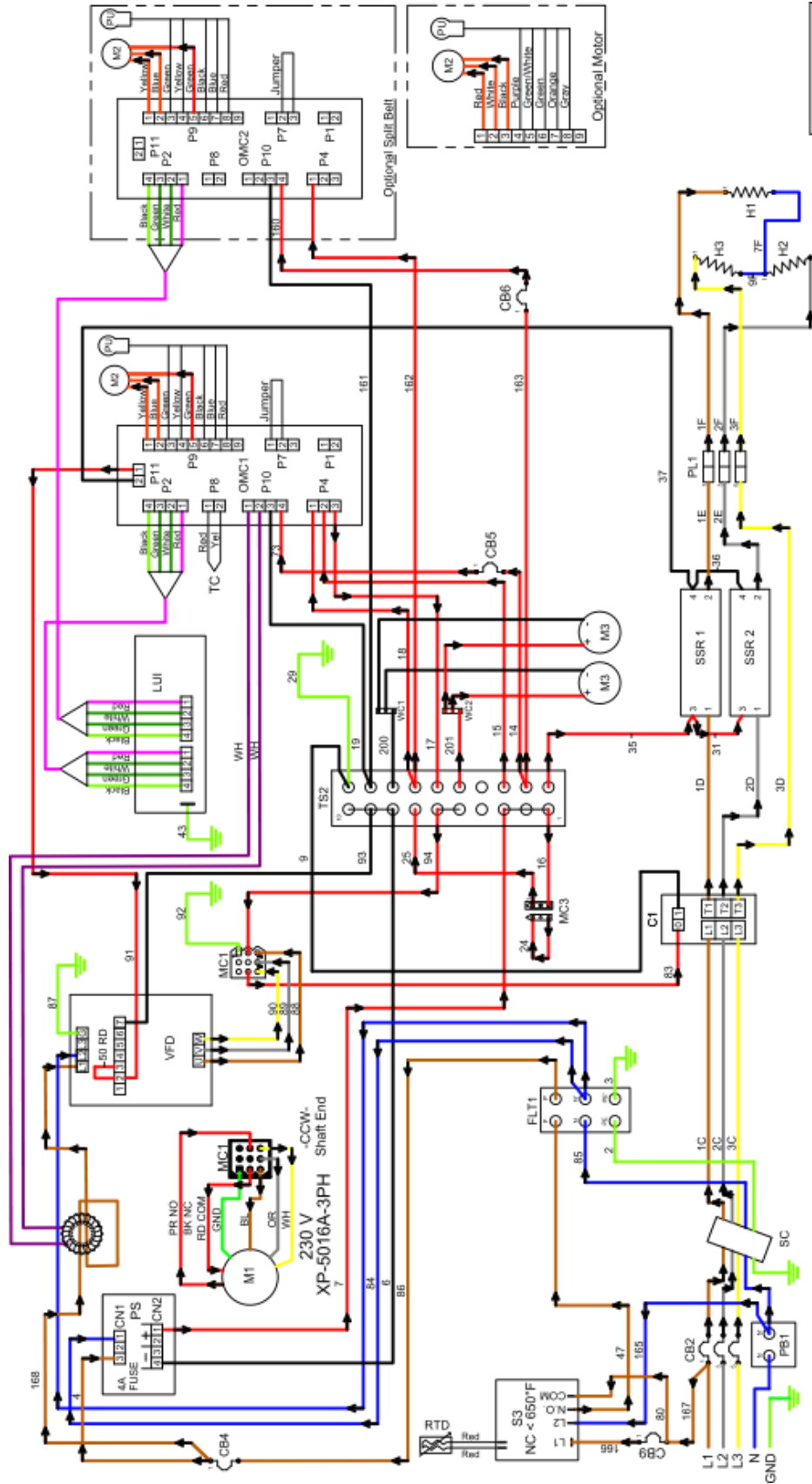

VOLTAGE COLOR KEY:

Red	24VDC+
Black	24VDC-
White	5VDC+
Blue	5VDC-
Green	380V/AC(L1)
Yellow	380V/AC(L2)
Orange	380V/AC(L3)
Purple	485V/AC(N)
Grey	485V/AC(G)
Light Blue	Ground
Light Green	Analog Volts

X3H-1832
X3H-2336

380/415 VAC 3 PH 50 Hz
XD-9130H02-380/415-5300-3
RH Controls Right Side
10/4/2022

- C1 Contactor, 70 Amp
- CB2 Circuit Breaker, 63 Amp, Heating Elements
- CB4 Circuit Breaker, 10 Amp, Main
- CB5 Circuit Breaker, 1/2 Amp, Conveyor Motor
- CB6 Circuit Breaker, 1/2 Amp, Conveyor Motor
- CB9 Circuit Breaker, 1/2 Amp, High Limit
- FLT1 Power Filter, EMI
- H1-H3 Heating Element, 240 VAC, 5300 W
- LUI Large User Interface
- M1 Motor, Oven Fan
- M2 Motor, Conveyor
- M3 Motor, Cooling Fan
- OMC1 Oven Machine Control, Main
- OMC2 Oven Machine Control, Split Belt
- PB1 Power Block
- PL1 Push Lock, 1-3 Elements
- PS Power Supply
- RTD RTD, High Limit
- S3 Switch, High Limit
- SC Suppression Core
- SSR1 Solid State Relay, 75 Amp
- SSR2 Solid State Relay, 75 Amp
- TC Thermocouple
- TS2 Terminal Strip
- VFD Oven Fan Motor Frequency Drive
- WC1 Wago Connector
- WC2 Wago Connector

[Reference Wire Numbers, Wire Colors Subject To Change Without Notice]



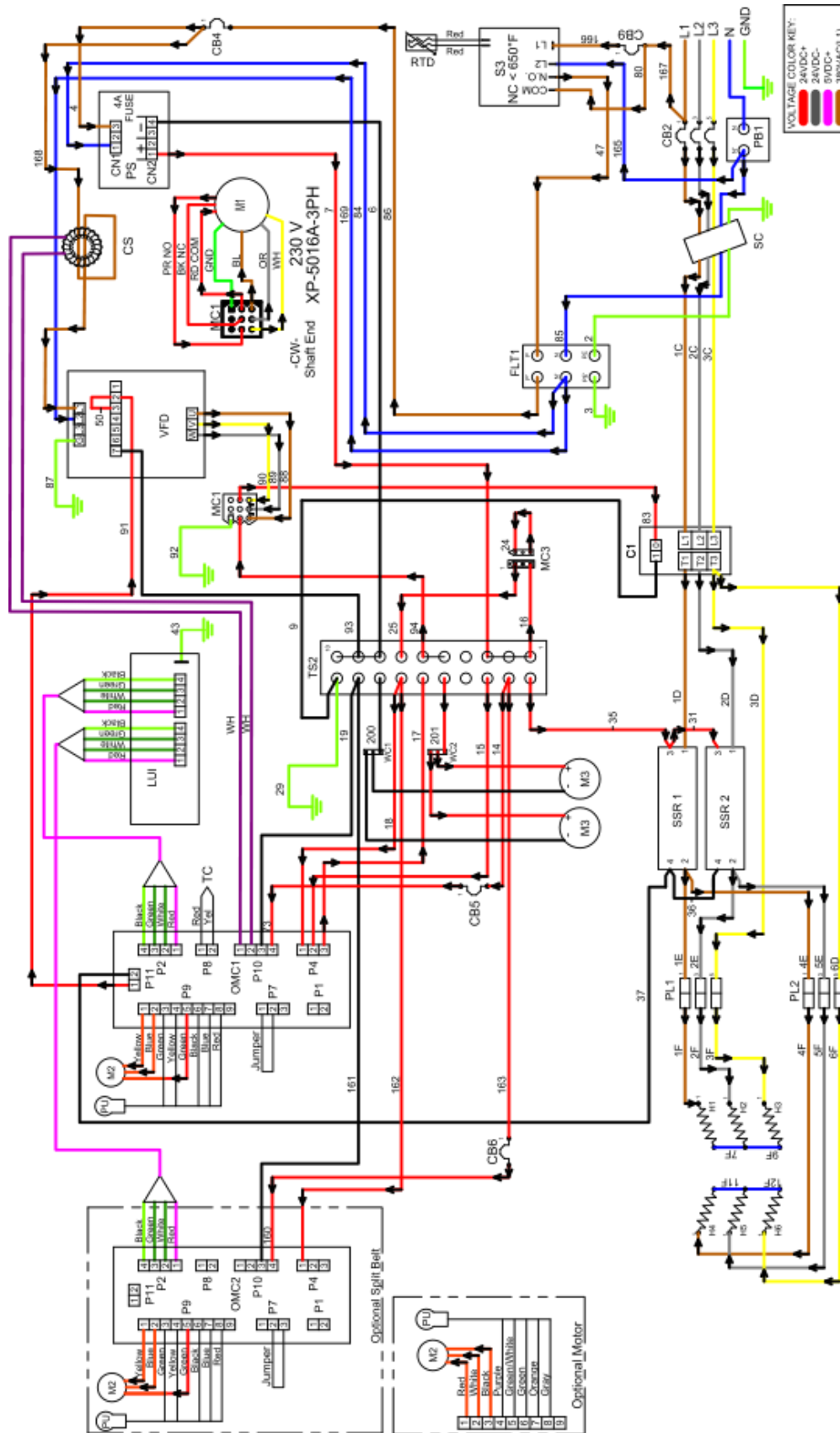

- | | | | | | |
|-------|---|------|----------------------------------|------|--------------------------------|
| C1 | Contactor, 70 Amp | M1 | Motor, Oven Fan | RTD | RTD, High Limit |
| CB2 | Circuit Breaker, 63 Amp, Heating Elements | M2 | Motor, Conveyor | S3 | Switch, High Limit |
| CB4 | Circuit Breaker, 10 Amp, Main | M3 | Motor, Cooling Fan | SC | Suppression Core |
| CB5 | Circuit Breaker, 1/2 Amp, Conveyor Motor | OMC1 | Oven Machine Control, Main | SSR1 | Solid State Relay, 75 Amp |
| CB6 | Circuit Breaker, 1/2 Amp, Conveyor Motor | OMC2 | Oven Machine Control, Split Belt | SSR2 | Solid State Relay, 75 Amp |
| CB9 | Circuit Breaker, 1/2 Amp, High Limit | PB1 | Power Block | TC | Thermocouple |
| FLT1 | Power Filter, EMI | PL1 | Push Lock, 1-3 Elements | TS2 | Terminal Strip |
| H1-H3 | Heating Element, 240 VAC, 4500 W | PL2 | Push Lock, 4-6 Elements | VFD | Oven Fan Motor Frequency Drive |
| H4-H6 | Heating Element, 240 VAC, 4500W | PS | Power Supply | WC1 | Wago Connector |
| LUI | Large User Interface | PU | Pick-Up | WC2 | Wago Connector |
- [Reference Wire Numbers; Wire Colors Subject To Change Without Notice]

X3H-2440
X3H-3240

380/415 VAC 3 PH 50 Hz
XD-9130H02-380/415-4500-6
LH Controls Left Side
10/4/2022

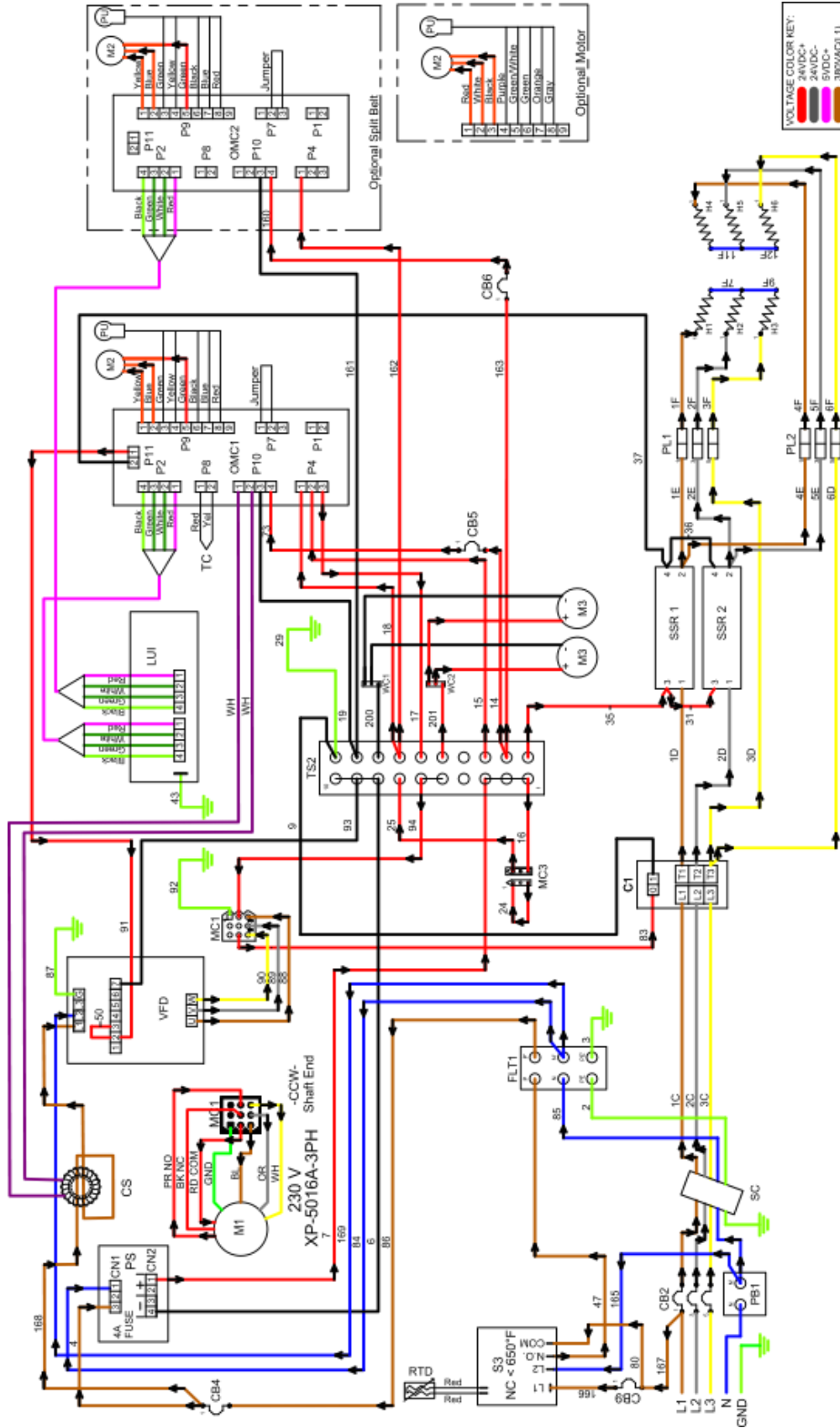

VOLTAGE COLOR KEY:

Red	24VDC+
Black	24VDC-
Yellow	5VDC+
Green	5VDC-
Orange	380V/415VAC(L1)
Blue	380V/415VAC(L2)
Purple	380V/415VAC(L3)
White	380V/415VAC(N)
Grey	485-480V
Light Blue	Ground
Light Green	Analog Voltage

X3H-2440
X3H-3240

380/415 VAC 3 PH 50 Hz
XD-9130H02-380/415-4500-6
RH Controls Right Side
10/4/2022

- C1 Contactor, 70 Amp
- C2 Circuit Breaker, 63 Amp, Heating Elements
- CB4 Circuit Breaker, 10 Amp, Main
- CB5 Circuit Breaker, 1/2 Amp, Conveyor Motor
- CB6 Circuit Breaker, 1/2 Amp, Conveyor Motor
- CB9 Circuit Breaker, 1/2 Amp, High Limit
- FLT1 Power Filter, EMI
- H1-H3 Heating Element, 208 Or 240 VAC, 4500 W
- H4-H6 Heating Element, 208 Or 240 VAC, 4500 W
- LUI Large User Interface
- M1 Contactor, 70 Amp
- M2 Motor, Oven Fan
- M3 Motor, Conveyor
- MC1 Motor, Cooling Fan
- MC2 Oven Machine Control, Main
- PB1 Oven Machine Control, Split Belt
- PL1 Power Block
- PL2 Push Lock, 1-3 Elements
- PL3 Push Lock, 4-6 Elements
- PS Power Supply
- PU Pick-Up
- RTD RTD, High Limit
- S3 Switch, High Limit
- SC Suppression Core
- SSR1 Solid State Relay, 75 Amp
- SSR2 Solid State Relay, 75 Amp
- TC Thermocouple
- TS2 Terminal Strip
- VFD Oven Fan Motor Frequency Drive
- WC1 Wago Connector
- WC2 Wago Connector

[Reference Wire Numbers; Wire Colors Subject To Change Without Notice]

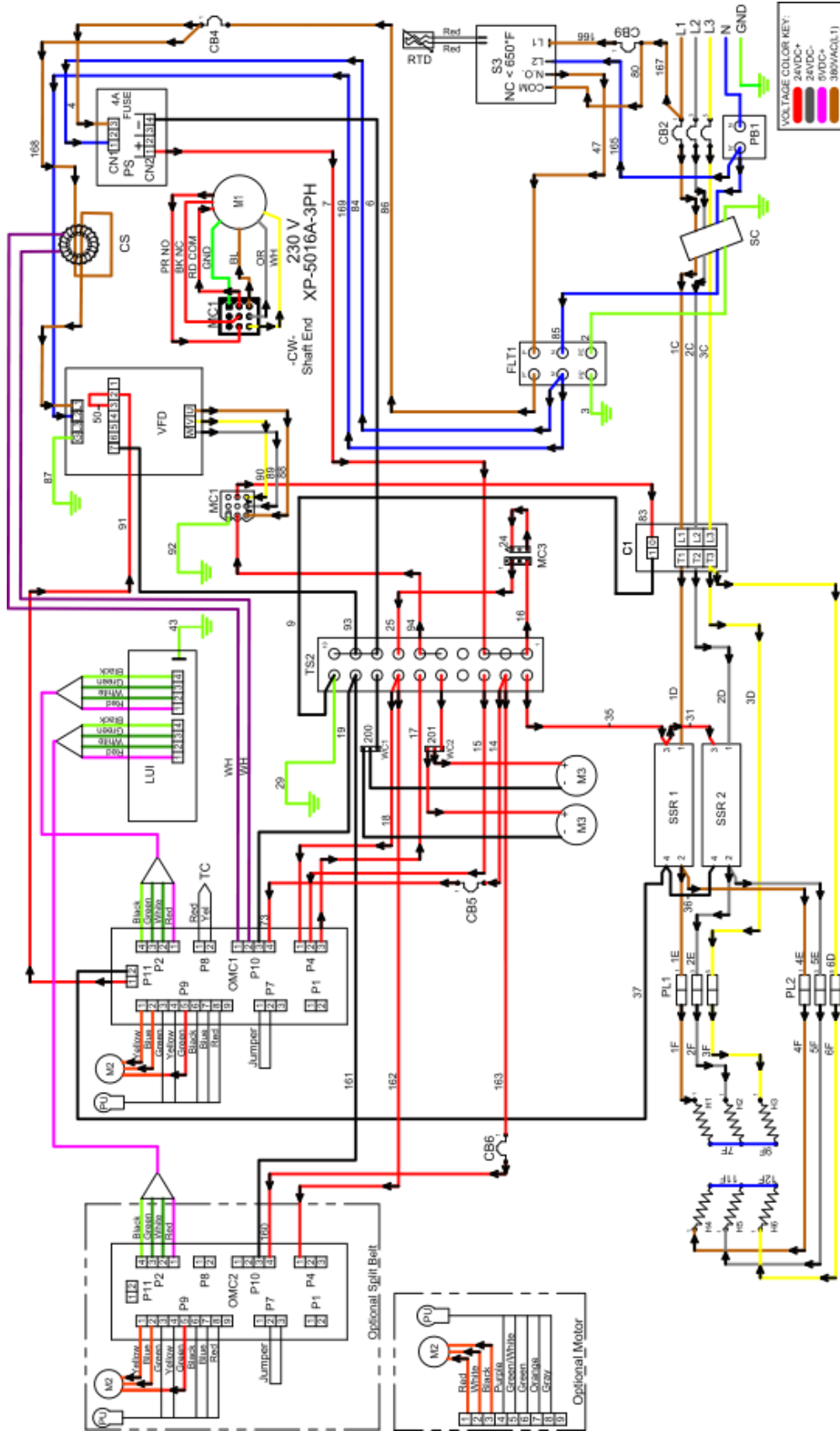

- VOLTAGE COLOR KEY:**
 24VDC+ (Red)
 24VDC- (Black)
 30VDC (White)
 380VAC(L1) (Yellow)
 380VAC(L2) (Green)
 380VAC(L3) (Blue)
 380VAC(N) (Purple)
 485V485V (Orange)
 Ground (Grey)
 Analog Volts (Light Green)
- Legend:**
 C1 Contactor, 70 Amp
 CB2 Circuit Breaker, 63 Amp, Heating Elements
 CB4 Circuit Breaker, 10 Amp, Main
 CB5 Circuit Breaker, 1/2 Amp, Conveyor Motor
 CB6 Circuit Breaker, 1/2 Amp, Conveyor Motor
 CB9 Circuit Breaker, 1/2 Amp, High Limit
 FLT1 Power Filter, EMI
 H1-H3 Heating Element, 240 VAC, 5300 W
 H4-H6 Heating Element, 240 VAC, 5300 W
 LUI Large User Interface
 M1 Motor, Oven Fan
 M2 Motor, Conveyor
 M3 Motor, Cooling Fan
 OMC1 Oven Machine Control, Main
 OMC2 Oven Machine Control, Split Belt
 P1 Power Block
 P11 Push Lock, 1-3 Elements
 P2 Push Lock, 4-6 Elements
 P9 Power Supply
 P10 Pick-Up
 P8 Power-Up
 P4 Power-Up
 P1 Jumper
 PU Jumper
 RTD RTD
 S3 Switch, High Limit
 SC Suppression Core
 SSR1 Solid State Relay, 75 Amp
 SSR2 Solid State Relay, 75 Amp
 TC Thermocouple
 TS2 Terminal Strip
 VFD Oven Fan Motor Frequency Drive
 WC1 Wago Connector
 WC2 Wago Connector
- Specifications:**
 X3H-3255
 X3H-3855
 X3H-4455
 380/415 VAC 3 PH 50 Hz
 XD-9130H02-380/415-5300-6
 LH Controls Left Side
- 10/4/2022

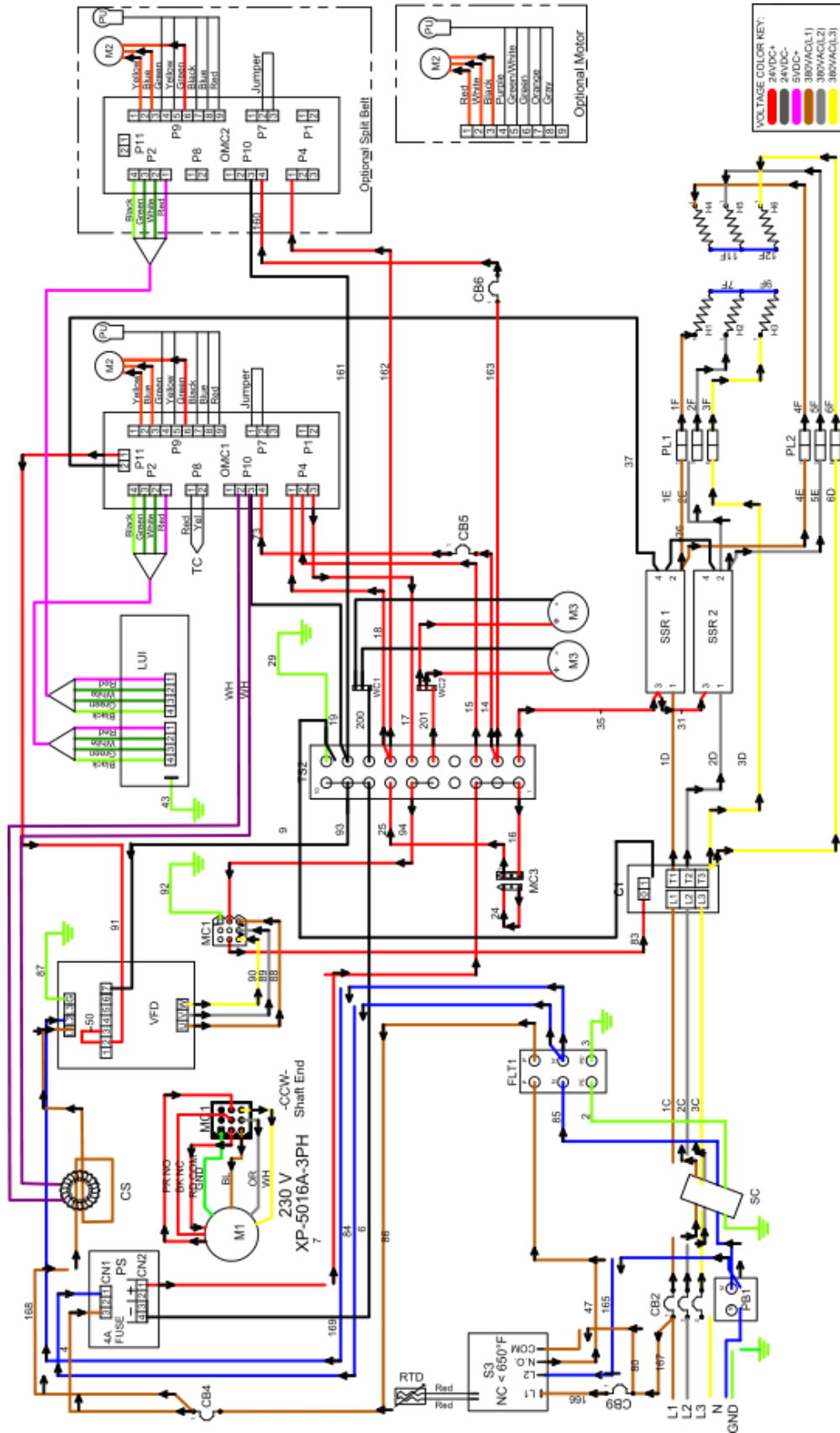

VOLTAGE COLOR KEY:

Red	24VDC+
Black	5VDC+
Yellow	380VAC(L1)
Blue	380VAC(L2)
Green	380VAC(L3)
White	380VAC(N)
Orange	485+485-
Grey	Ground
Green	Analog Volts

- X3H-3255
- X3H-3855
- X3H-4455

380/415 VAC 3 PH 50 HZ
 XD-9130H02-380/415-5300-6
 RH Controls Right Side
 10/4/2022

- RTD, High Limit
- Switch, High Limit
- Suppression Core
- Solid State Relay, 75 Amp
- Solid State Relay, 75 Amp
- Thermocouple
- Terminal Strip
- Oven Fan Motor Frequency Drive
- Wago Connector
- Wago Connector

- RTD
- S3
- SC
- SSR1
- SSR2
- TC
- TS2
- VFD
- WC1
- WC2

- Motor, Oven Fan
- Motor, Conveyor
- Motor, Cooling Fan
- Oven Machine Control, Main
- Oven Machine Control, Split Belt
- Power Block
- Push Lock, 1-3 Elements
- Push Lock, 4-6 Elements
- Power Supply
- Pick-Up

- M1
- M2
- M3
- OMC1
- OMC2
- PB1
- PL1
- PL2
- PS
- PU

- C1
- Contactor, 70 Amp
- Circuit Breaker, 63 Amp, Heating Elements
- Circuit Breaker, 10 Amp, Main
- Circuit Breaker, 1/2 Amp, Conveyor Motor
- Circuit Breaker, 1/2 Amp, Conveyor Motor
- Circuit Breaker, 1/2 Amp, High Limit
- Power Filter, EMI
- Heating Element, 240 VAC, 5300 W
- Heating Element, 240 VAC, 5300 W
- Large User Interface

- CB1
- CB2
- CB4
- CB5
- CB6
- CB9
- FLT1
- H1-H3
- H4-H6
- LUI

[Reference Wire Numbers; Wire Colors Subject To Change Without Notice]



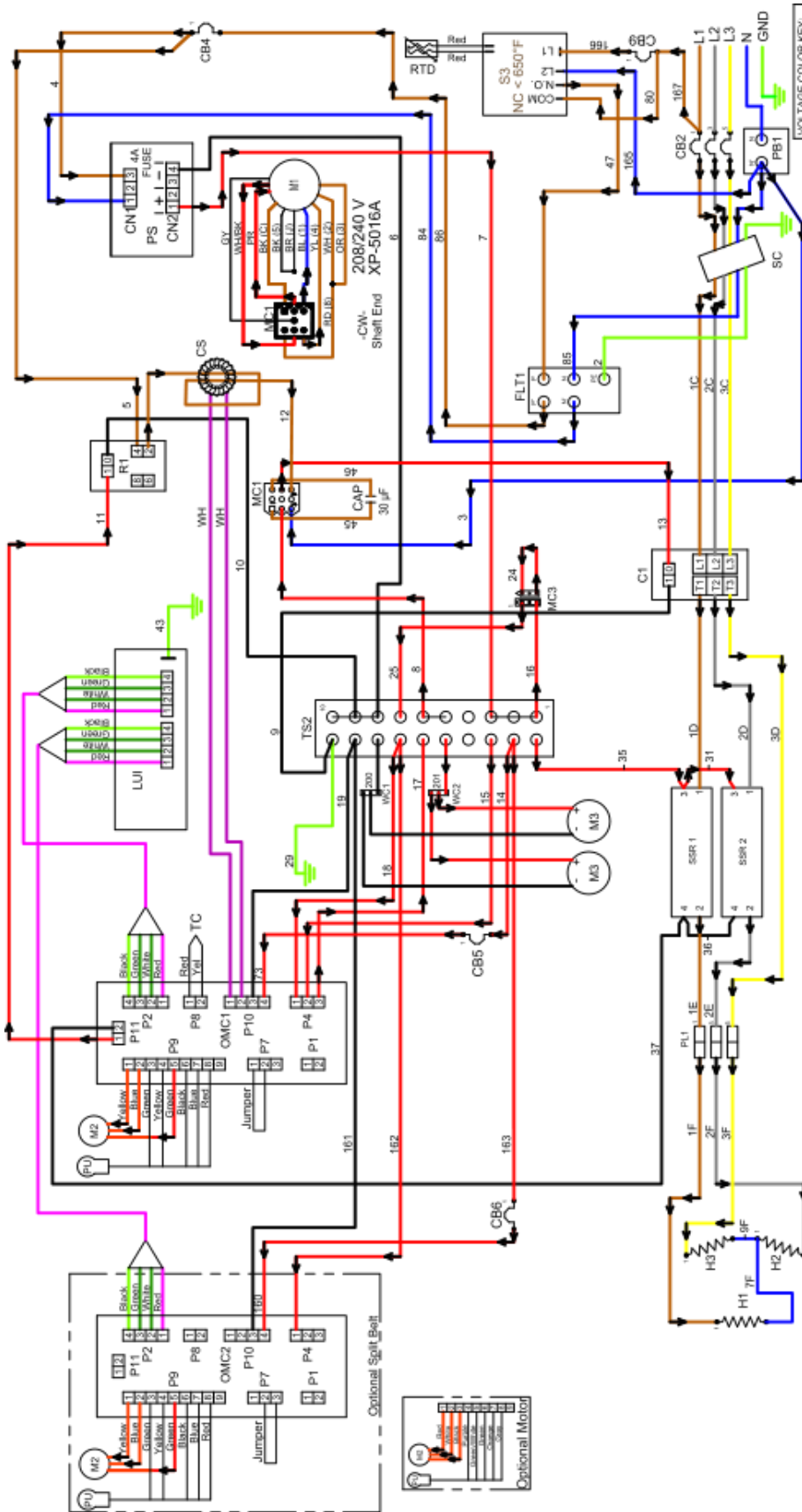

VOLTAGE COLOR KEY:

Red	24VDC+
Orange	24VDC
Yellow	380VAC(L1)
Green	380VAC(L2)
Blue	380VAC(L3)
Purple	380VAC(N)
Black	485+485-
White	Ground
Grey	Analog Volts

X3H-1832
X3H-2336

380/415 VAC 3 PH 50 Hz
XD-9130H02-380/415-NV-5300-3 LH
LH Controls Left Side
10/4/2022

- Oven Fan Motor Relay
- RTD, High Limit
- Switch, High Limit
- Suppression Core
- Solid State Relay, 75 Amp
- Solid State Relay, 75 Amp
- Thermocouple
- Terminal Strip
- Wago Connector
- Wago Connector

- R1
- RTD
- S3
- SC
- SSR1
- SSR2
- TC
- TS2
- WC1
- WC2

- Large User Interface
- Motor, Oven Fan
- Motor, Conveyor
- Motor, Cooling Fan
- Oven Machine Control, Main
- Oven Machine Control, Split Belt
- Power Block
- Push Lock, 1-3 Elements
- Power Supply
- Pick-Up

- C1
- Contactor, 70 Amp
- CAP
- Capacitor, 30µF
- CB2
- Circuit Breaker, 63 Amp, Heating Elements
- CB4
- Circuit Breaker, 7 Amp, Main
- CB5
- Circuit Breaker, 1/2 Amp, Conveyor Motor
- CB6
- Circuit Breaker, 1/2 Amp, Conveyor Motor
- CB9
- Circuit Breaker, 1/2 Amp, High Limit
- CS
- Current Sensor
- FLT1
- Power Filter, EMI
- H1-H3
- Heating Element, 240 VAC, 5300 W

(Reference Wire Numbers; Wire Colors Subject To Change Without Notice)

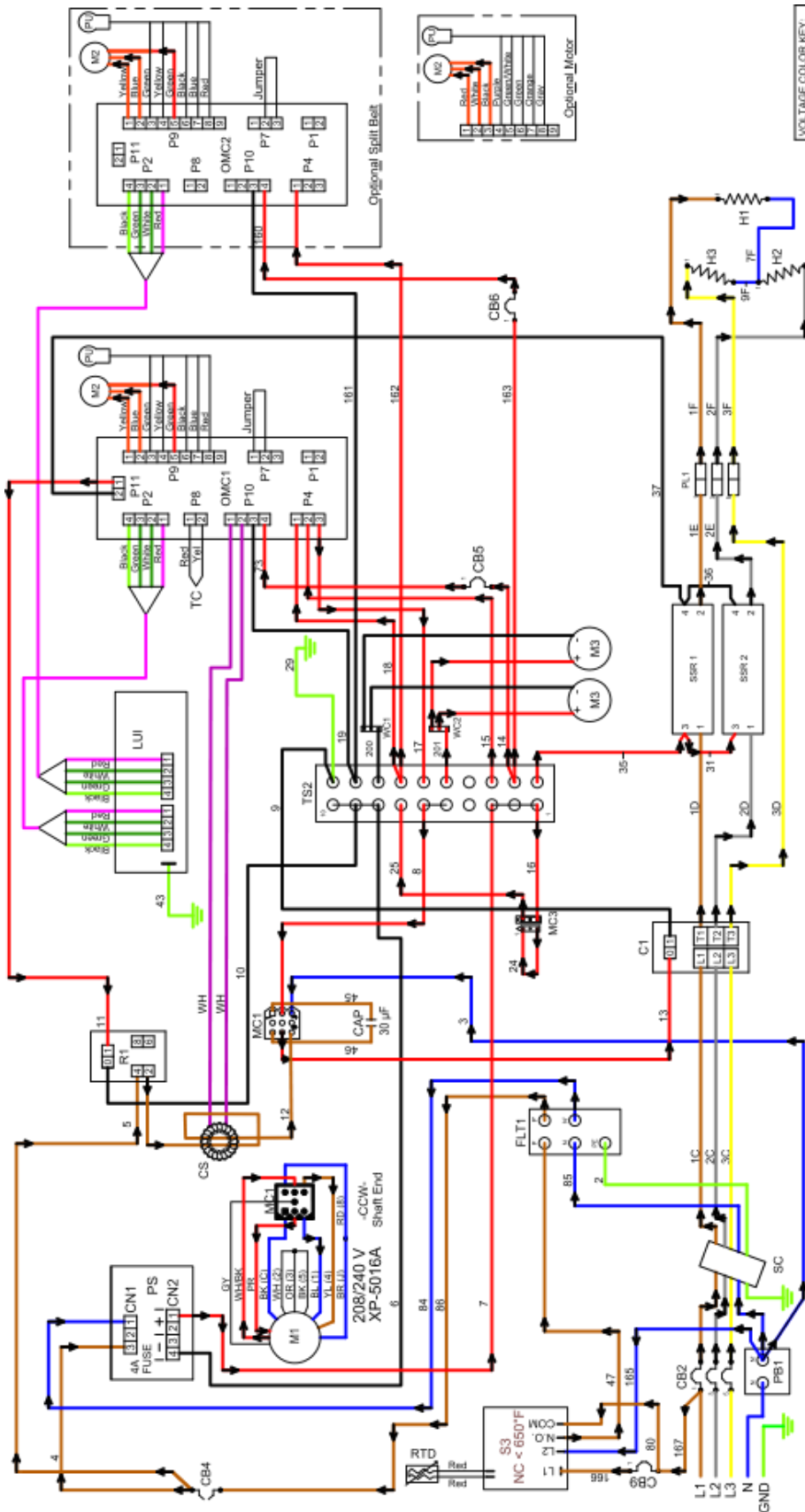

VOLTAGE COLOR KEY:

Blue	480VAC
Red	240VAC
Black	5VDC+
White	5VDC-
Green	380VAC(L1)
Yellow	380VAC(L2)
Orange	380VAC(L3)
Purple	380VAC(N)
Grey	485V+485-
Light Blue	Ground
Light Green	Analog Voltage

X3H-1832
X3H-2336

380/415 VAC 3 PH 50 Hz
XD-9130H02-380/415-NV-5300-3 RH
RH Controls Right Side
10/4/2022

- C1 Contactor, 70 Amp
- CAP Capacitor 30µF
- CB2 Circuit Breaker, 63 Amp, Heating Elements
- CB4 Circuit Breaker, 7 Amp, Main
- CB5 Circuit Breaker, 1/2 Amp, Conveyor Motor
- CB6 Circuit Breaker, 1/2 Amp, Conveyor Motor
- CB9 Circuit Breaker, 1/2 Amp, High Limit
- CS Current Sensor
- FLT1 Power Filter, EMI
- H1-H3 Heating Element, 240 VAC, 5300 W
- LUI Large User Interface
- M1 Motor, Oven Fan
- M2 Motor, Conveyor
- M3 Motor, Cooling Fan
- MMC Oven Machine Control, Main
- OMC1 Oven Machine Control, Split Belt
- OMC2 Power Block
- PB1 Push Lock, 1-3 Elements
- PS Power Supply
- PU Pick-Up
- R1 Oven Fan Motor Relay
- RTD RTD, High Limit
- S3 Switch, High Limit
- SC Suppression Core
- SSR1 Solid State Relay, 75 Amp
- SSR2 Solid State Relay, 75 Amp
- TC Thermocouple
- TS2 Terminal Strip
- WC1 Wago Connector
- WC2 Wago Connector

[Reference Wire Numbers; Wire Colors Subject To Change Without Notice]

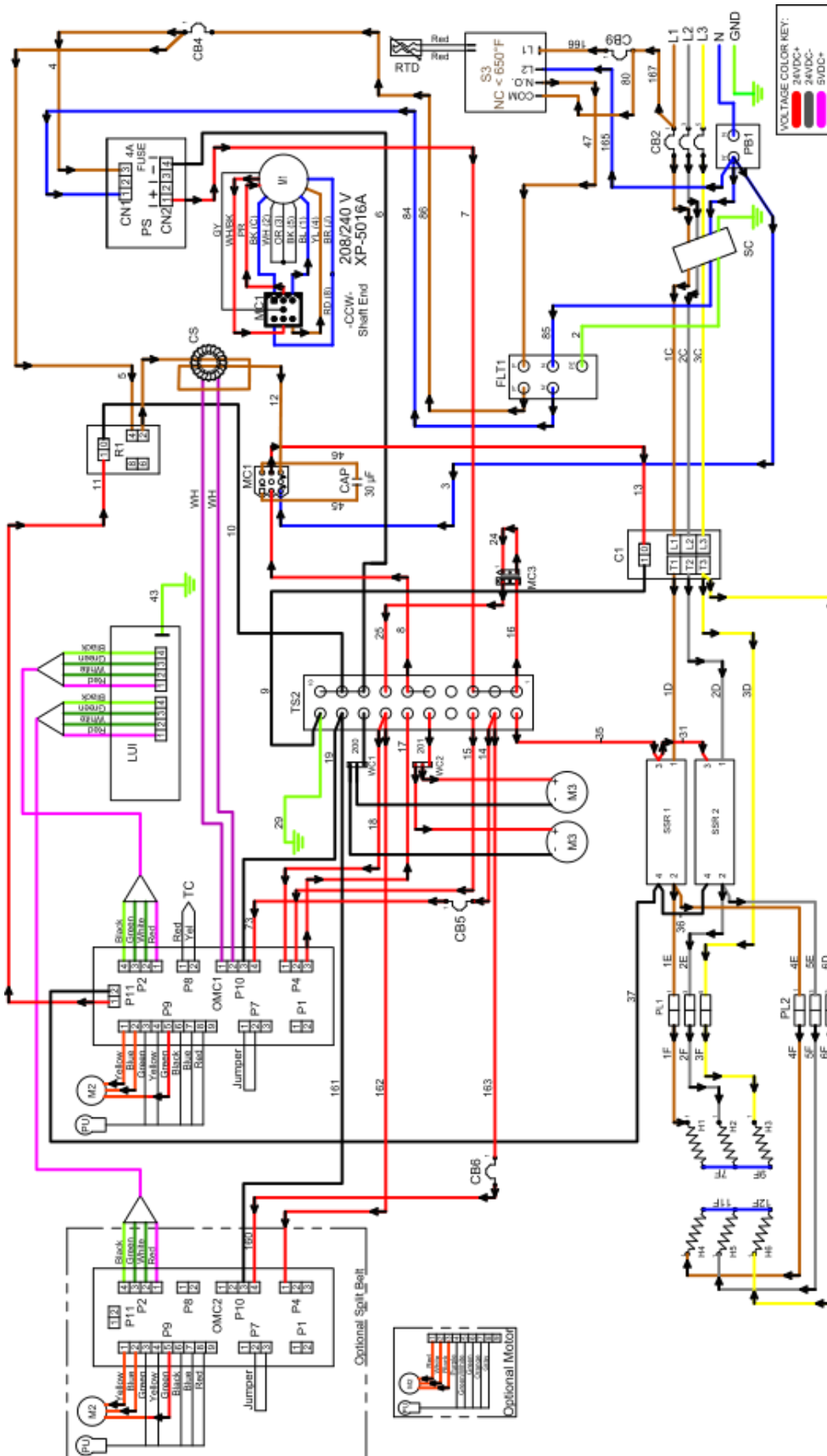

VOLTAGE COLOR KEY:

Red	240VDC+
Orange	240VDC-
Yellow	50VDC
Green	380VAC(L1)
Blue	380VAC(L2)
Purple	380VAC(L3)
Black	380VAC(N)
White	485-485
Grey	Ground
Light Blue	Arising Voltage

X3H-2440
X3H-3240
380/415 VAC 3 PH 50 Hz
XD-9130H02-380/415-NV-4500-6 LH
LH Controls Left Side
10/4/2022

- C1 Contactor, 70 Amp
- CB2 Circuit Breaker, 63 Amp, Heating Elements
- CB4 Circuit Breaker, 7 Amp, Main
- CB5 Circuit Breaker, 1/2 Amp, Conveyor Motor
- CB6 Circuit Breaker, 1/2 Amp, Conveyor Motor
- CS Current Sensor
- FLT1 Power Filter, EMI
- H1-H3 Heating Element, 208 Or 240 VAC, 4500 W
- H4-H6 Heating Element, 208 Or 240 VAC, 4500 W
- LUI Large User Interface
- M1 Contactor, 70 Amp
- M2 Motor, Oven Fan
- M3 Motor, Conveyor Fan
- MC1 Motor, Cooling Fan
- MC2 Oven Machine Control, Main
- MC3 Oven Machine Control, Split Belt
- PB1 Power Block
- PL1 Push Lock, 1-3 Elements
- PL2 Push Lock, 4-6 Elements
- PS Power Supply
- PU Pick-Up
- R1 Oven Fan Motor Relay
- RTD RTD, High Limit
- S3 Switch, High Limit
- SC Suppression Core
- SSR1 Solid State Relay, 75 Amp
- SSR2 Solid State Relay, 75 Amp
- TC Thermocouple
- TS2 Terminal Strip
- WC1 Wago Connector
- WC2 Wago Connector

[Reference Wire Numbers; Wire Colors Subject To Change Without Notice]

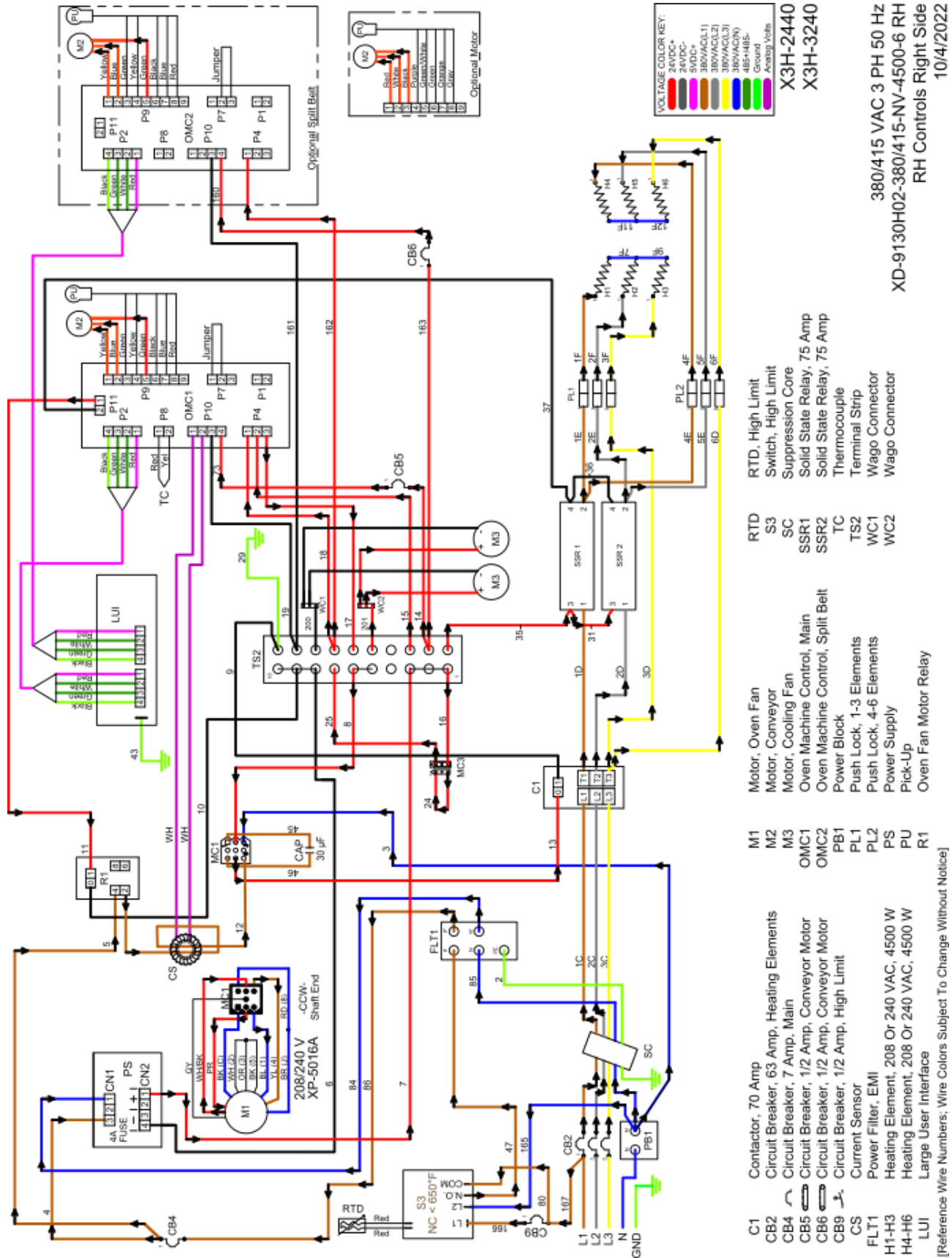

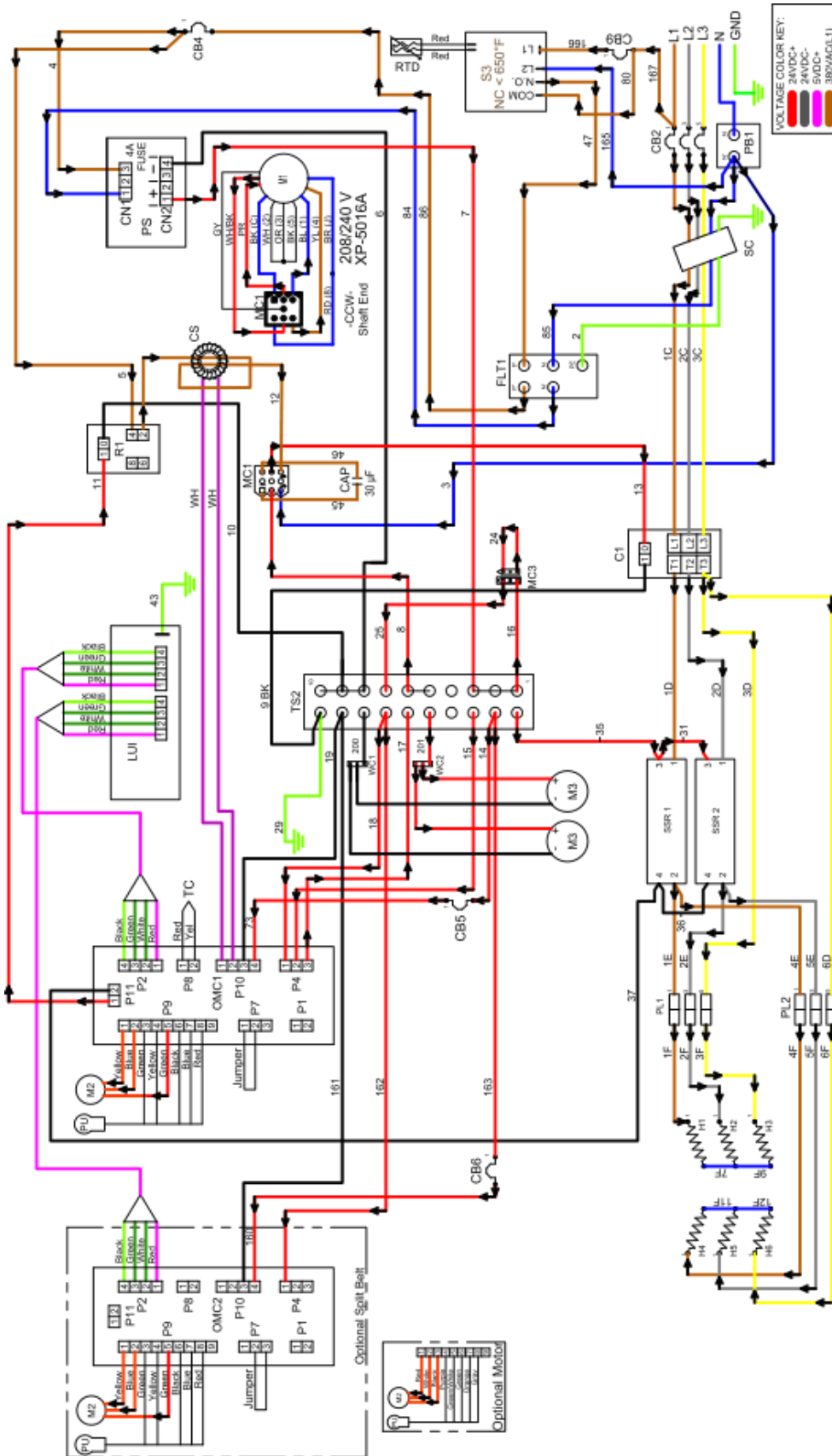

VOLTAGE COLOR KEY:

Red	24VDC+
Black	5VDC+
Blue	380VAC(L1)
Yellow	380VAC(L2)
Green	380VAC(L3)
White	380VAC(N)
Grey	485+485-
Light Blue	Ground
Light Green	Analog Volts

- | | | | | | |
|-------|---|------|----------------------------------|------|---------------------------|
| C1 | Contactor, 70 Amp | LUI | Large User Interface | R1 | Oven Fan Motor Relay |
| CB2 | Circuit Breaker, 63 Amp, Heating Elements | M1 | Motor, Oven Fan | RTD | RTD, High Limit |
| CB4 | Circuit Breaker, 7 Amp, Main | M2 | Motor, Conveyor | S3 | Switch, High Limit |
| CB5 | Circuit Breaker, 1/2 Amp, Conveyor Motor | M3 | Motor, Cooling Fan | SC | Suppression Core |
| CB6 | Circuit Breaker, 1/2 Amp, Conveyor Motor | OMC1 | Oven Machine Control, Main | SSR1 | Solid State Relay, 75 Amp |
| CB9 | Circuit Breaker, 1/2 Amp, High Limit | OMC2 | Oven Machine Control, Split Belt | SSR2 | Solid State Relay, 75 Amp |
| CS | Current Sensor | PB1 | Power Block | TC | Thermocouple |
| FLT1 | Power Filter, EMI | PL1 | Push Lock, 1-3 Elements | TS2 | Terminal Strip |
| H1-H3 | Heating Element, 240 VAC, 5300 W | PL2 | Push Lock, 4-6 Elements | WC1 | Wago Connector |
| H4-H6 | Heating Element, 240 VAC, 5300 W | PS | Power Supply | WC2 | Wago Connector |
| | | PU | Pick-Up | | |

X3H-3255
 X3H-3855
 X3H-4455
 380/415 VAC 3 PH 50 Hz
 XD-9130H02-380/415-NV-5300-6 LH
 LH Controls Left Side
 10/4/2022

[Reference Wire Numbers. Wire Colors Subject To Change Without Notice]

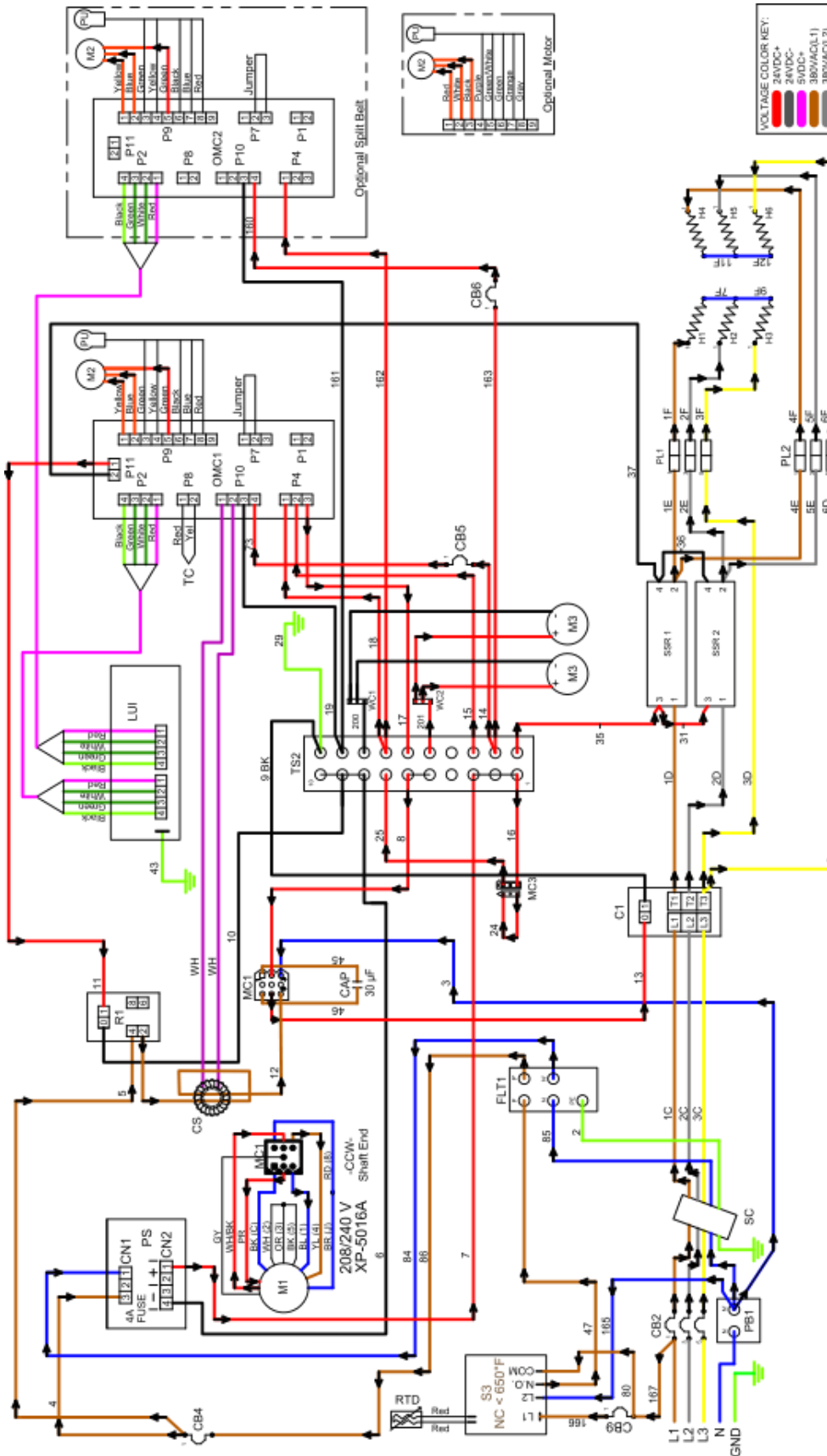

VOLTAGE COLOR KEY:

Red	24VDC+
Black	5VDC+
Yellow	380V/ACL(L1)
Green	380V/ACL(L2)
Blue	380V/ACL(L3)
White	380V/AC(N)
Grey	Ground-B
Green	Ground-G
Blue	Analog Volts

- C1 Contactor, 70 Amp
- CB2 Circuit Breaker, 63 Amp, Heating Elements
- CB4 Circuit Breaker, 7 Amp, Main
- CB5 Circuit Breaker, 1/2 Amp, Conveyor Motor
- CB9 Circuit Breaker, 1/2 Amp, Conveyor Motor
- CS Current Sensor
- FLT1 Power Filter, EMI
- H1-H3 Heating Element, 240 VAC, 5300 W
- H4-H6 Heating Element, 240 VAC, 5300 W
- LUI Large User Interface
- M1 Motor, Oven Fan
- M2 Motor, Conveyor
- M3 Motor, Cooling Fan
- OMC1 Oven Machine Control, Main
- OMC2 Oven Machine Control, Split Belt
- PB1 Power Block
- PL1 Push Lock, 1-3 Elements
- PL2 Push Lock, 4-6 Elements
- PS Power Supply
- PU Pick-Up
- RTD RTD, High Limit
- S3 Switch, High Limit
- SC Suppression Core
- SSR1 Solid State Relay, 75 Amp
- SSR2 Solid State Relay, 75 Amp
- TC Thermocouple
- TS2 Terminal Strip
- WC1 Wago Connector
- WC2 Wago Connector

380/415 VAC 3 PH 50 Hz
 XD-9130H02-380/415-NV-5300-6 RH
 RH Controls Right Side
 10/4/2022

[Reference Wire Numbers; Wire Colors Subject To Change Without Notice]

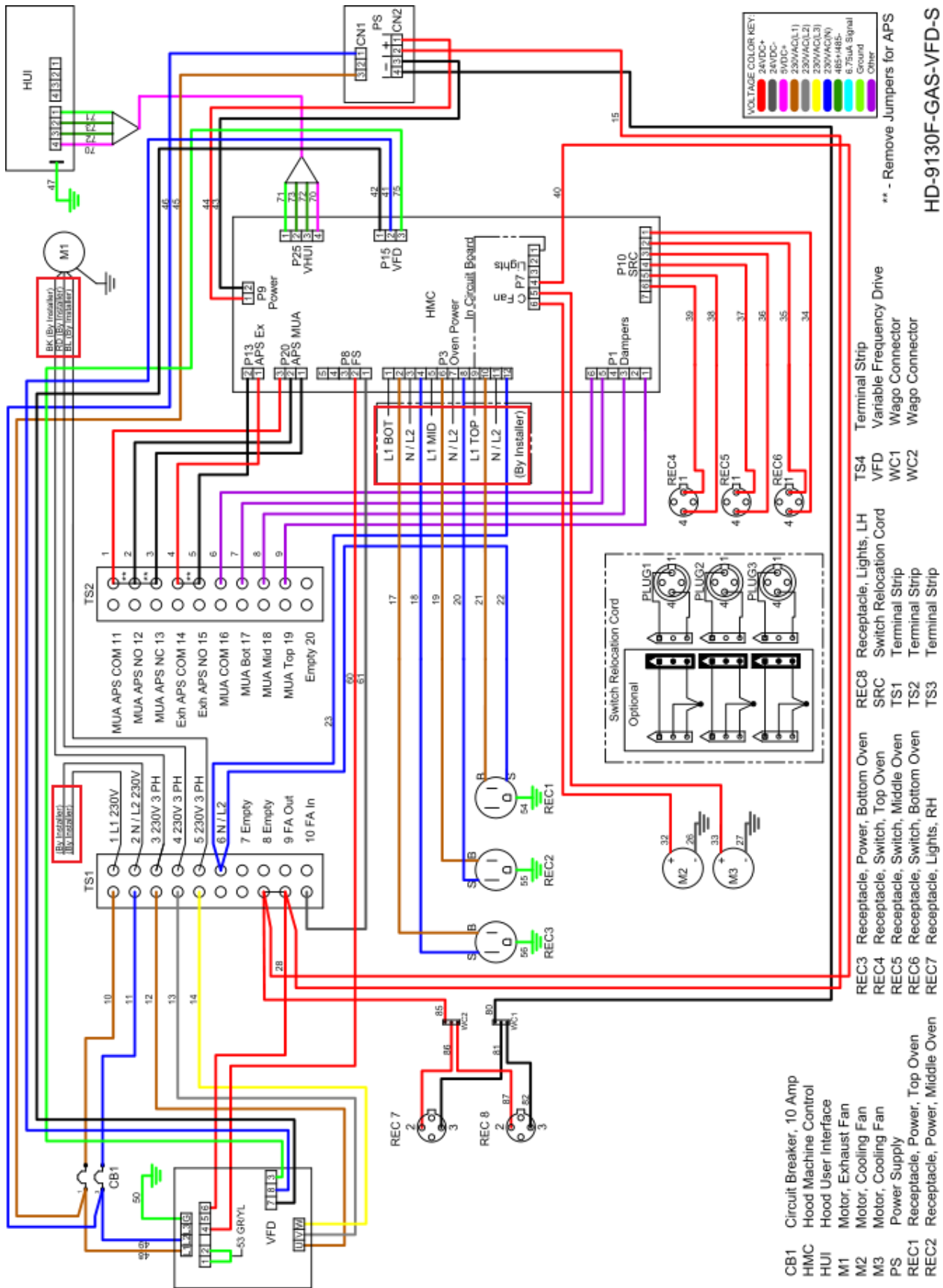

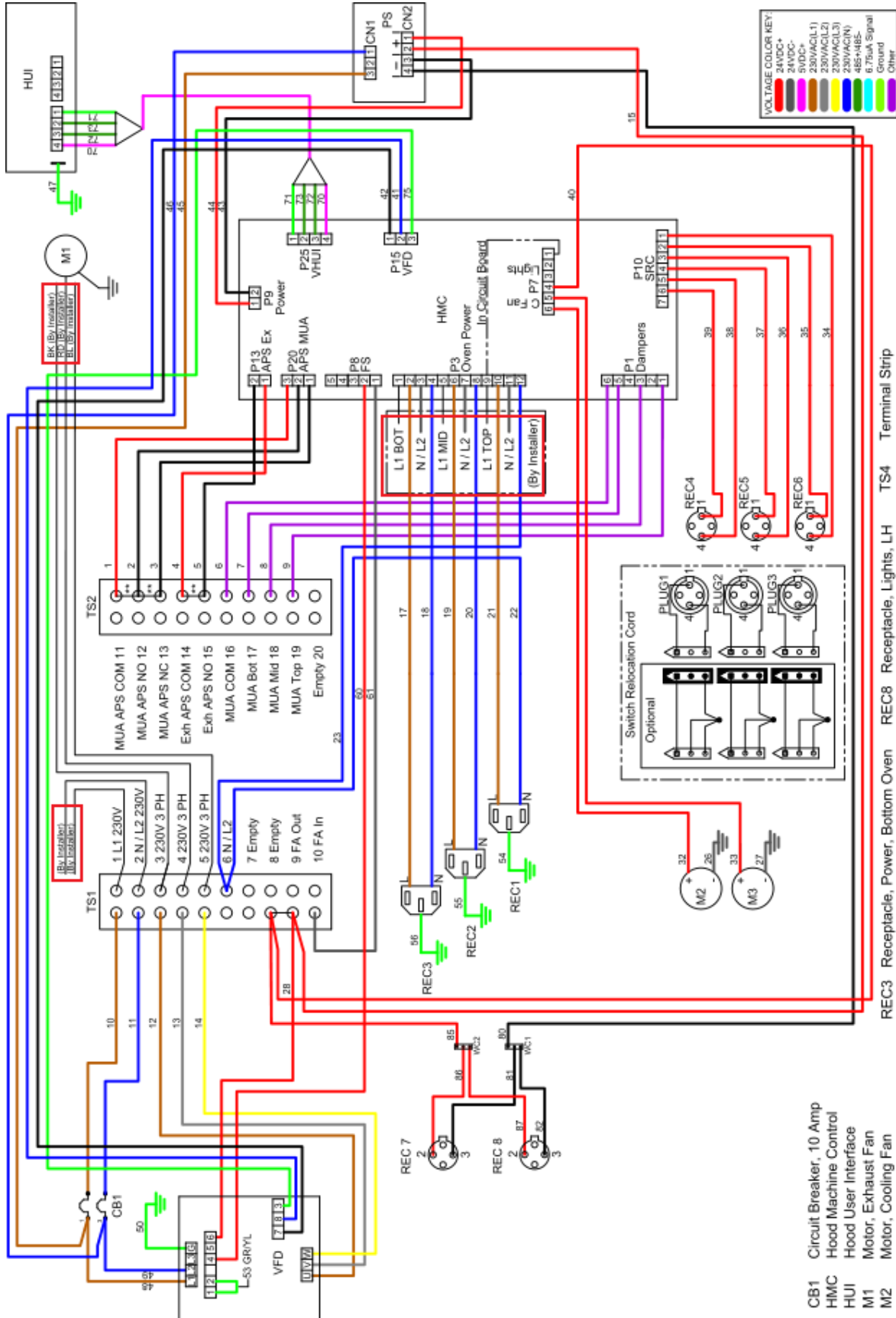

- CB1 Circuit Breaker, 10 Amp
- HMC Hood Machine Control
- HUI Hood User Interface
- M1 Motor, Exhaust Fan
- M2 Motor, Cooling Fan
- M3 Motor, Cooling Fan
- PS Power Supply
- REC1 Receptacle, Power, Top Oven
- REC2 Receptacle, Power, Middle Oven
- REC3 Receptacle, Power, Bottom Oven
- REC4 Receptacle, Switch, Top Oven
- REC5 Receptacle, Switch, Middle Oven
- REC6 Receptacle, Switch, Bottom Oven
- REC7 Receptacle, Lights, RH
- REC8 Receptacle, Lights, LH
- SRC Switch Relocation Cord
- TS1 Terminal Strip
- TS2 Terminal Strip
- TS3 Terminal Strip
- TS4 Terminal Strip
- VFD Variable Frequency Drive
- WC1 Wago Connector
- WC2 Wago Connector

** - Remove Jumpers for APS

HD-9130F-GAS-VFD-W

5/16/2022

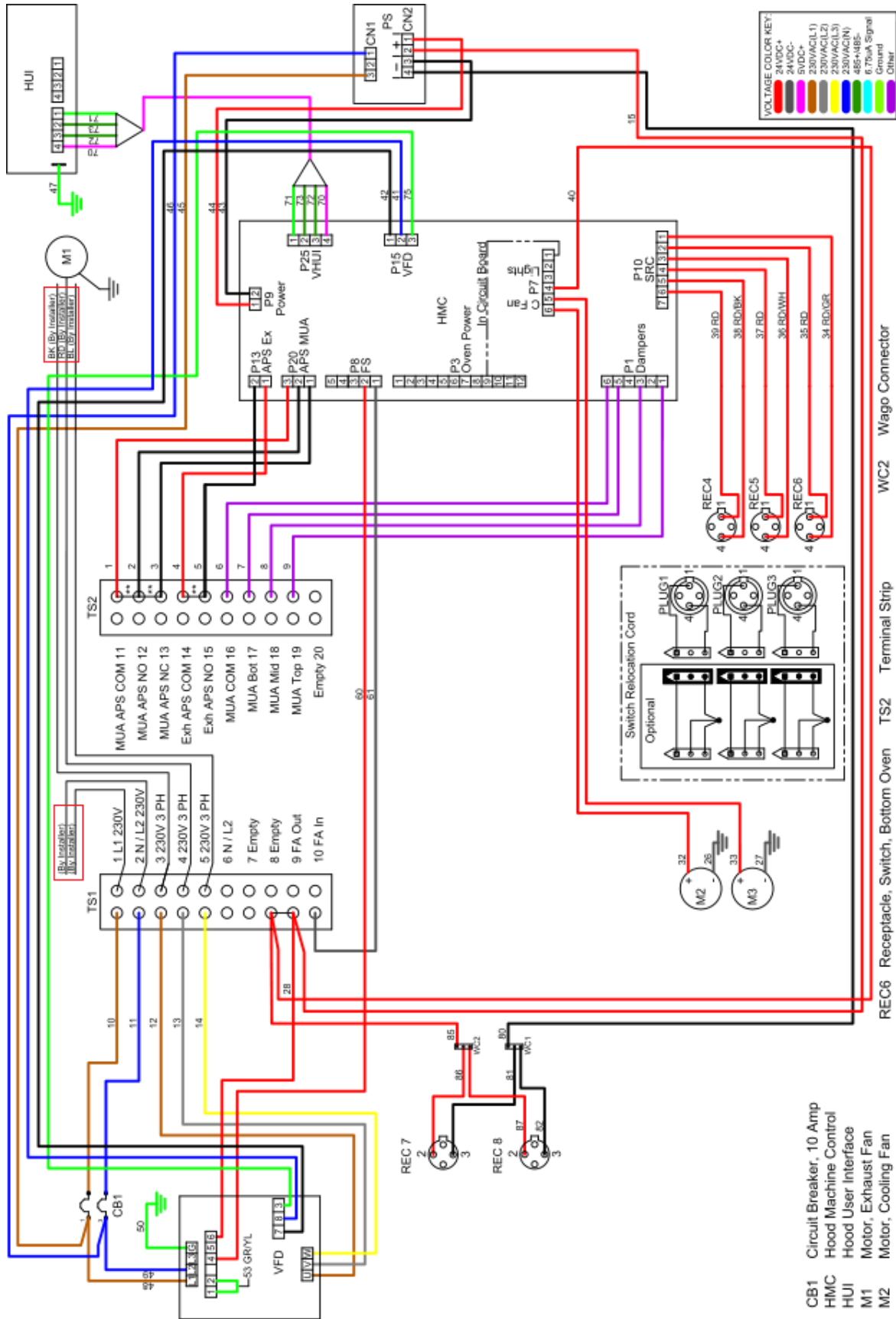

VOLTAGE COLOR KEY:

Red	24VDC+
Orange	24VDC-
Yellow	5VDC+
Green	5VDC-
Blue	230VAC(L1)
Black	230VAC(L2)
White	230VAC(L3)
Grey	230VAC(N)
Light Blue	485+485-
Light Green	6.75mA Signal
Light Purple	Ground
Light Yellow	Other

- CB1 Circuit Breaker, 10 Amp
- HMC Hood Machine Control
- HUI Hood User Interface
- M1 Motor, Exhaust Fan
- M2 Motor, Cooling Fan
- M3 Motor, Cooling Fan
- PS Power Supply
- REC4 Receptacle, Switch, Top Oven
- REC5 Receptacle, Switch, Middle Oven
- REC6 Receptacle, Switch, Bottom Oven
- REC7 Receptacle, Lights, RH
- REC8 Receptacle, Lights, LH
- SRC Switch Relocation Cord
- TS1 Terminal Strip
- TS2 Terminal Strip
- TS3 Terminal Strip
- TS4 Terminal Strip
- VFD Variable Frequency Drive
- WC1 Wago Connector
- WC2 Wago Connector

** - Remove Jumpers for APS

HD-9130F-ELE-VFD
5/16/2022

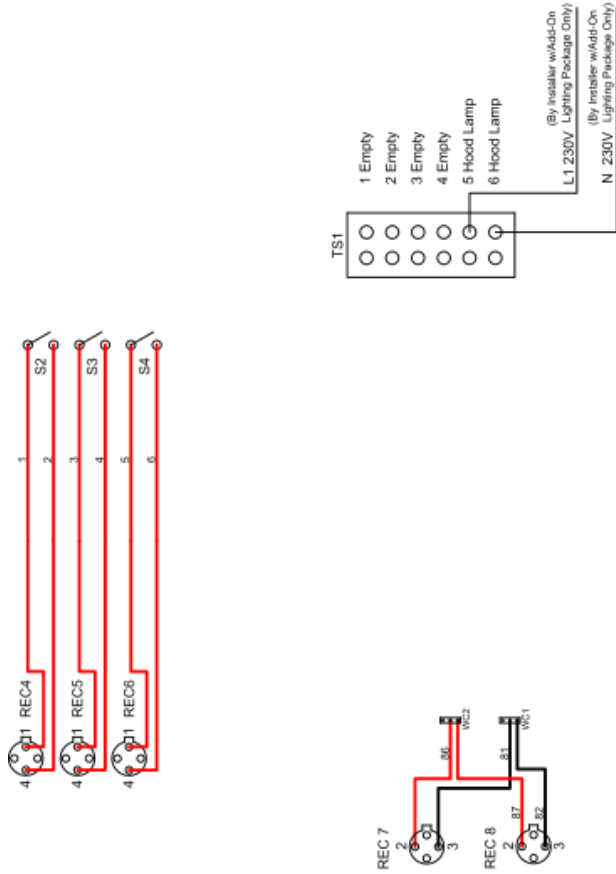

VOLTAGE COLOR KEY

Red	240VDC
Orange	230V(AC)L1
Blue	230V(AC)N
Green	Ground

HD-9130F-NV
5/16/2022

- REC4 Receptacle, Top Oven
- REC5 Receptacle, Middle Oven
- REC6 Receptacle, Bottom Oven
- REC7 Receptacle, Lights, RH
- REC8 Receptacle, Lights, LH
- S2 Switch, Top Oven
- S3 Switch, Middle Oven
- S4 Switch, Bottom Oven
- TS1 Terminal Strip

[Reference Wire Numbers; Wire Colors Subject To Change Without Notice]

Product Certifications and Applicable Codes

Standard XLT Oven Certifications¹

XLT Gas Ovens:

1. ANSI Z83.11-2016/CSA 1.8-2016 Standard for Gas Food Service Equipment
2. ANSI /NSF 4-2016 Sanitation for Commercial Cooking Rethermalization and Powered Hot Food Holding and Transportation Equipment

XLT Electric Ovens:

1. ANSI/UL197-CSA C22.2 Commercial Electric Appliances
2. ANSI /NSF 4-2016 Sanitation for Commercial Cooking Rethermalization & Powered Hot Food Holding & Transportation Equipment

World XLT Oven Certifications¹

XLT Gas Ovens:

1. EN 60335-1:2002 +A11, A1:2004 +A12, A2:2006 +A1 Low Voltage Directive (LVD)
2. EN 55014-1:2006 +A1:2009 +A2:2011 EN 61000-3-2:2018, EN 61000-3-3:2013 Electromagnetic Compatibility. (EMC)
3. EN 55014-2:2015 Conducted Emissions, Surge Immunity
4. BS EN 203-1:2014, Gas Heated Catering Equipment; General Safety Rules
5. BS EN 203-2-1:2006, Standard for Gas Heated Catering Equipment; Specific Requirements Ovens
6. BS EN 203-3:2009, Gas Heated Catering Equipment; Materials and Parts in Contact with Food and Other Sanitary Aspects
7. EN 60335-2-102:2004 +A1:2008 +A2:2012 Gas Appliance Regulation (GAR)

XLT Electric Ovens:

1. EN 60335-2-42:2002 +A1:2008 Safety of Household Appliances and Similar Electrical Appliances
2. EN 60335-1:2010 +A1:2013 Low Voltage Directive (LVD)
3. EN 55014-2:2015 Conducted Emissions, Surge Immunity
4. EN 61000-3-2:2014 Electromagnetic Compatibility. (EMC)
5. EN 61000-3-3:2013 +A1+A2 Voltage fluctuation
6. EN 61000-6-3:2007 +A1:2011 EMC Immunity for residential, commercial & light industrial

¹ The noted certifications for XLT ovens and XLT Hood are performed and documented by Intertek Testing Services NA Inc. 165 Main Street, Cortland, NY 13045.

Intertek is a nationally and internationally certified testing and accreditation agency.

² The certifications for Australia are administered and verified by the SAI Global Pty Limited 680 George Street, Sydney NSW 2000, GPO Box 5420 Sydney NSW 2001

³ 402 Hannuri-daero, Sejong-si, 339-012, Republic of Korea

Product Certifications and Applicable Codes

Australian XLT Oven Certifications²

XLT Gas Ovens: (Certificate GAS40066)

1. AS 4563-2004 Commercial Catering Gas Equipment
2. AS/NZ 3350.1:2002 Safety of Household and Similar Appliances

Korea XLT Oven Certifications³

XLT Gas Ovens: (Certificate GA-107)

1. Meets KGS-AB338 Facility/Technical/Inspection Code For Manufacture of Commercial Gas Burning Appliances.

Standard and World XLT Hood Certifications¹

1. UL 710 Standard for Safety Exhaust Hoods for Commercial Cooking
2. ANSI/NSF 2:2014 Sanitation Food Equipment
3. ULC-S646, Standard for Exhaust Hoods and Related Controls for Commercial and Institutional Kitchens

¹ The noted certifications for XLT ovens and XLT Hood are performed and documented by Intertek Testing Services NA Inc. 165 Main Street, Cortland, NY 13045.

Intertek is a nationally and internationally certified testing and accreditation agency.

² The certifications for Australia are administered and verified by the SAI Global Pty Limited 680 George Street, Sydney NSW 2000, GPO Box 5420 Sydney NSW 2001

³ 402 Hannuri-daero, Sejong-si, 339-012, Republic of Korea

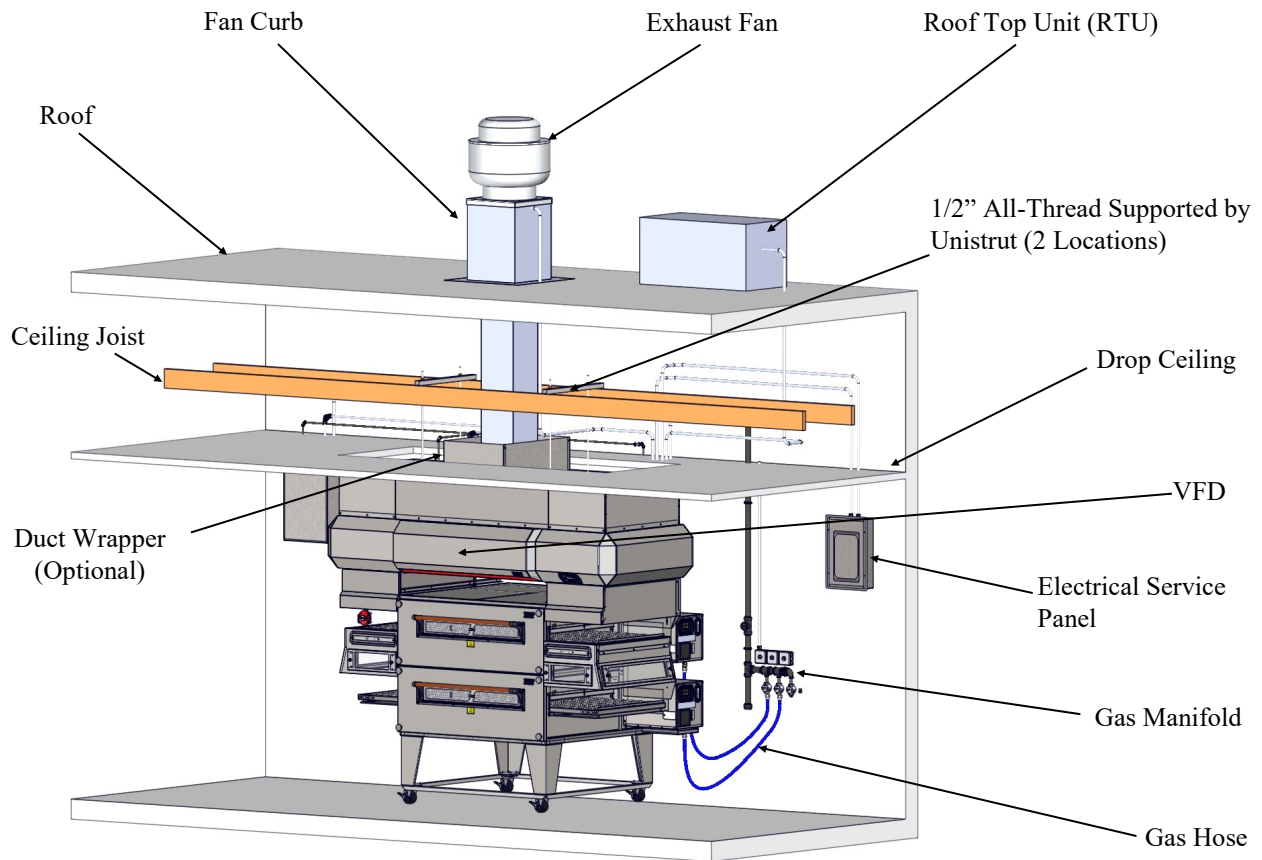

*The above image shown is a Gas Oven Configuration

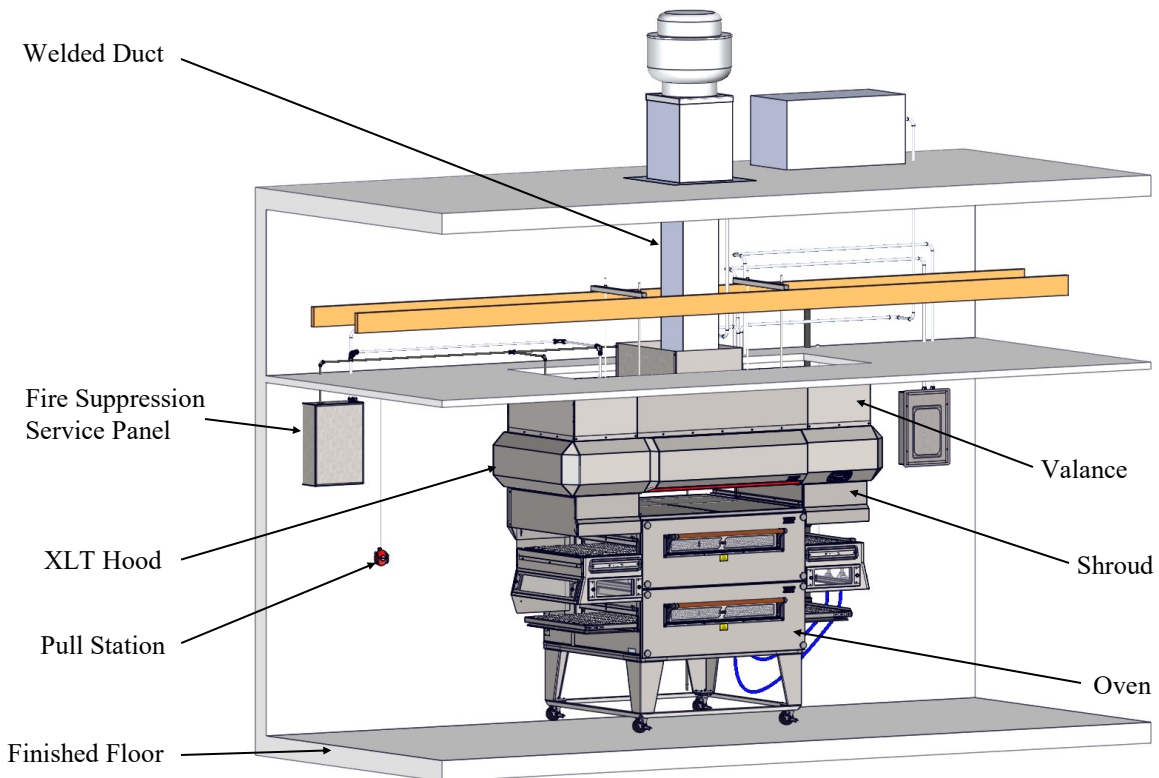

*The above image shown is a Gas Oven Configuration

Oven Initial Start-up Checklist - Remove and Return to XLT Ovens

Fill out all information and print legibly

Start-Up Information Customer Name: _____ Company Name: _____ Phone #: _____ Email: _____ Address: _____ City: _____ State: _____ Zip: _____ Country: _____	
Follow Requirements outlined in Installation and Operation Manual <u>Oven Install and Start-up Requirements:</u> <input type="checkbox"/> Gas Requirements met (Gas Ovens Only) <ul style="list-style-type: none"> • One shut off valve per oven installed; if not, call XLT as this may void warranty <input type="checkbox"/> Electrical Requirements met <input type="checkbox"/> Clearances met <input type="checkbox"/> Oven(s) installed and stacked properly <ul style="list-style-type: none"> • XLT is not stacked on another manufacturer's ovens; if it is, call XLT as this may void warranty <input type="checkbox"/> Oven(s) were powered on and functioned as designed <input type="checkbox"/> Conveyor chain tensioned properly upon installation	Follow Requirements outlined in Installation and Operation Manual <u>Hood Install and Start-up Requirements:</u> <input type="checkbox"/> Electrical Requirements met <input type="checkbox"/> Clearances/ Height Requirement met <input type="checkbox"/> Hood installed properly <input type="checkbox"/> Shrouds installed properly <ul style="list-style-type: none"> • Ovens are under hood with shrouds attached <input type="checkbox"/> Ventilation Requirements met <input type="checkbox"/> Hood was powered on and functions as designed <input type="checkbox"/> Ovens function properly through the Hood
Oven Information <u>Top Oven</u> Serial Number: _____ Model Number: _____ <u>Middle Oven</u> Serial Number: _____ Model Number: _____ <u>Bottom Oven</u> Serial Number: _____ Model Number: _____	Hood Information Serial Number: _____ Model Number: _____
<div style="display: flex; align-items: center; justify-content: flex-end;">  <div style="text-align: left;"> <p>XLT Ovens PO Box 9090 Wichita, KS 67277 FAX: 316-943-2769 Email: startup@xltovens.com</p> </div> </div>	

Start-up can be submitted via mail, fax, email or submit online (using QR code above or go to xltovens.com/startup).

Print Name: _____ Signature: _____ Date: _____

