

XLT[®]

SmartSolutions[™]

XD 9006A
AKSWH05HF02
9/3/2024



XLT Gas Oven & XLT Hood Parts & Service Manual



Read This Manual Before Using This Appliance.

Electronic copies of this manual, Technical Specifications, Installation & Operation Manual, Architectural Drawings, & a list of International Authorized Distributors are available at: www.xltovens.com

For use with the following XLT Gas Oven Versions:

Australia (A)	H
Korea (K)	H
Standard (S)	H
World (W)	H

For use with the following XLT Hood Versions:

Standard (S)	F
World (W)	F



Original Instructions

XLT Ovens
PO Box 9090
Wichita, Kansas 67277
US: 888-443-2751 FAX: 316-943-2769 INTL: +1-316-943-2751 WEB: www.xltovens.com



Post in a prominent location instructions to be followed in the event you smell gas. This information can be obtained by consulting your local gas supplier.



FOR YOUR SAFETY

Do not store or use gasoline or other flammable vapors and liquids on the vicinity of this or any other appliance



Improper installation, adjustment, alteration, service or maintenance can cause property damage, injury, or death. Read the installation, operating and maintenance instructions thoroughly before installing or servicing this equipment.



This appliance is not intended for use by persons (including children) with reduced physical, sensory or mental capabilities, or lack of experience and knowledge, unless they have been given supervision or instruction concerning use of the appliance by a person responsible for their safety.

XLT has spent millions of dollars designing and testing our products as well as developing Installation & Operation Manuals. These manuals are the most complete and easiest to understand in the industry. However, they are worthless if they are not followed.

We have witnessed store operators and building owners lose many thousands of dollars in lost revenue due to incorrect installations. We highly recommend you follow all instructions given in this manual as well as follow best practices in plumbing, electrical, and HVAC building codes.

Revision History Table

Revision	Comments	Date
A	New Release	09/03/2024

Definitions & Symbols

A safety instruction (message) includes a “Safety Alert Symbol” & a signal word or phrase such as **DANGER**, **WARNING** or **CAUTION**. Each signal word has the following meaning:

 DANGER	<p>Indicates a potentially hazardous situation that, if not avoided, can result in serious injury or death.</p>
--	---



 HIGH VOLTAGE	<p>Indicates a high voltage. It calls your attention to items or operations that could be dangerous to you & other persons operating this equipment. Read the message & follow the instructions carefully.</p>
--	--

 WARNING	<p>Indicates a potentially hazardous situation, that if not avoided, can result in cuts or being crushed. It calls your attention to items or operations that could be dangerous to you & other persons operating this equipment.</p>
---	---

 CAUTION	<p>Indicates a potentially hazardous situation, that if not avoided, can result in minor to moderate injury or serious damage to the product. The situation described in the CAUTION may, if not avoided, lead to serious results. Important safety measures are described in CAUTION (as well as WARNING), so be sure to observe them.</p>
--	---

 NOTE	<p>NOTE indicates an area or subject of special merit, emphasizing either the product’s capability or common errors in operation or maintenance.</p>
--	--

 TIP	<p>TIP gives a special instruction that can save time or provide other benefits while installing or using the product. The tip calls attention to an idea that may not be obvious to first-time users of the product.</p>
---	---

 READ MANUAL	<p>Read the instructions before using this machine.</p>		<p>PROTECTIVE EARTH Terminal which is intended for connection to an external conductor.</p>
---	---	---	---



SAFETY DEPENDS ON YOU



This appliance is for professional use by qualified personnel. This appliance must be installed by qualified persons in accordance with the regulations in force. This appliance must be installed with sufficient ventilation to prevent the occurrence of unacceptable concentrations of substances harmful to health in the room in which it is installed. This appliance needs an unobstructed flow of fresh air for satisfactory operation & must be installed in a suitably ventilated room in accordance with current regulations. This appliance should be serviced by qualified personnel at least every twelve (12) months or sooner if heavy use is expected.



Installation and repairs of all electrical appliances & ventilation exhaust hoods should only be performed by a qualified professional who has read & understands these instructions & is familiar with proper safety precautions. Read this manual thoroughly before installing or servicing this equipment.

- Post in a prominent location instructions to be followed in the event you smell gas. This information can be obtained by consulting your local gas supplier.
- In the event a gas odor is detected, shut off the gas at the main shutoff valve immediately. Contact your local Gas Company or supplier.
- Do not restrict the flow of combustion and/or ventilation air to the unit. Provide adequate clearance for operating, cleaning, and maintaining and adequate clearance for operating the gas shutoff valve when the unit is in the installed position.
- Keep the area free and clear of combustible material. **DO NOT SPRAY AEROSOLS IN THE VICINITY OF THIS APPLIANCE WHILE IT IS IN OPERATION.**
- Ovens are certified for installation on either combustible or non-combustible floors, and adjacent to either combustible or non-combustible walls.
- Electrical schematics are located inside the control box of the oven, in this manual, and online at www.xltovens.com. Disconnect input power to the unit before performing any maintenance.
- This unit requires a ventilation hood that must conform to local codes.
- This unit may be operated with either natural gas or liquid petroleum fuel as designated on the data plate located on the side of the unit.
- This unit must be operated by the same voltage, phase, and frequency of electrical power as designated on the data plate located on the side of the unit.
- Minimum clearances must be maintained from combustible and non-combustible construction materials.
- Follow all local codes when installing this unit.
- Follow all local codes to electrically ground the unit.
- Appliance is not to be cleaned with water jet (high pressure water).
- XLT ovens are certified for use in stacks of up to four (4) units of XLT products. Integration of other manufacturer's products into an oven stack is not recommended, and voids any warranties. XLT assumes no liability for mixed product applications.
- Failure to call XLT Customer Service at 1-888-443-2751 prior to contacting a repair company voids any and all warranties.
- PLEASE RETAIN THIS MANUAL FOR FUTURE REFERENCE.

Warning & Safety Information.....	2
Table of Contents	5
General	6
Warranty.....	8
Installation Responsibilities	10
Oven Theory of Operation	11
Hood Theory of Operation	20
Oven Troubleshooting.....	25
Hood Troubleshooting.....	27
Oven Service Procedures.....	29
Hood Service Procedures	37
Parts Ordering.....	39
Oven Parts	40
Hood Parts	90
Electrical Schematics	94
Certifications	122
Notes.....	124
Start-Up Checklist	125

For maintenance procedures, please refer to the XLT Installation & Operation Manual.

This manual, which contains an illustrated parts breakdown, has been prepared as an aid in understanding how the unit operates, how to diagnose problems, and order parts for the equipment. All of the parts, listed in the parts breakdown, are manufactured with the same precision as the original equipment.

XLT parts and service providers are available worldwide. There are authorized service providers located in the principle cities of the United States. There are also authorized Distributors located throughout the world.

The Theory of Operation section describes how the unit operates. An understanding of normal operation will greatly aid diagnosis and troubleshooting. The Troubleshooting section contains information about service error codes including the display read outs, MC LEDs, error determinations and troubleshooting actions. The illustrated parts section identifies the various sub-assemblies and detailed parts which make up the equipment, as well as the part number. An explanation of how to order parts is included.

This manual is designed to supplement the Installation & Operation Manual provided with the unit when new. Please refer to it for descriptions, dimensions, weights, electrical requirements, maintenance schedules, and certifications.

XLT wants you to be totally satisfied with every aspect of owning & using your oven & hood. Your feedback, both positive & negative, is very important to us as it helps us understand how to improve our products & our company. Our goal is to provide you with equipment that we can be proud to build & you can be proud to own.

To receive technical support for the oven or hood you purchased, XLT has qualified customer service personnel that can provide assistance on any type of XLT equipment problem you may experience. Customer Service is available 24/7/365 at 888-443-2751 or visit www.xltovens.com.

Save this Manual

This document is the property of the owner of this equipment.

XLT reserves the right to make changes in design & specifications, and/or make additions to or improvements to its product without imposing any obligations upon itself to install them in products previously manufactured.

All Right Hand & Left Hand designations in this manual are from the point of view as seen below.

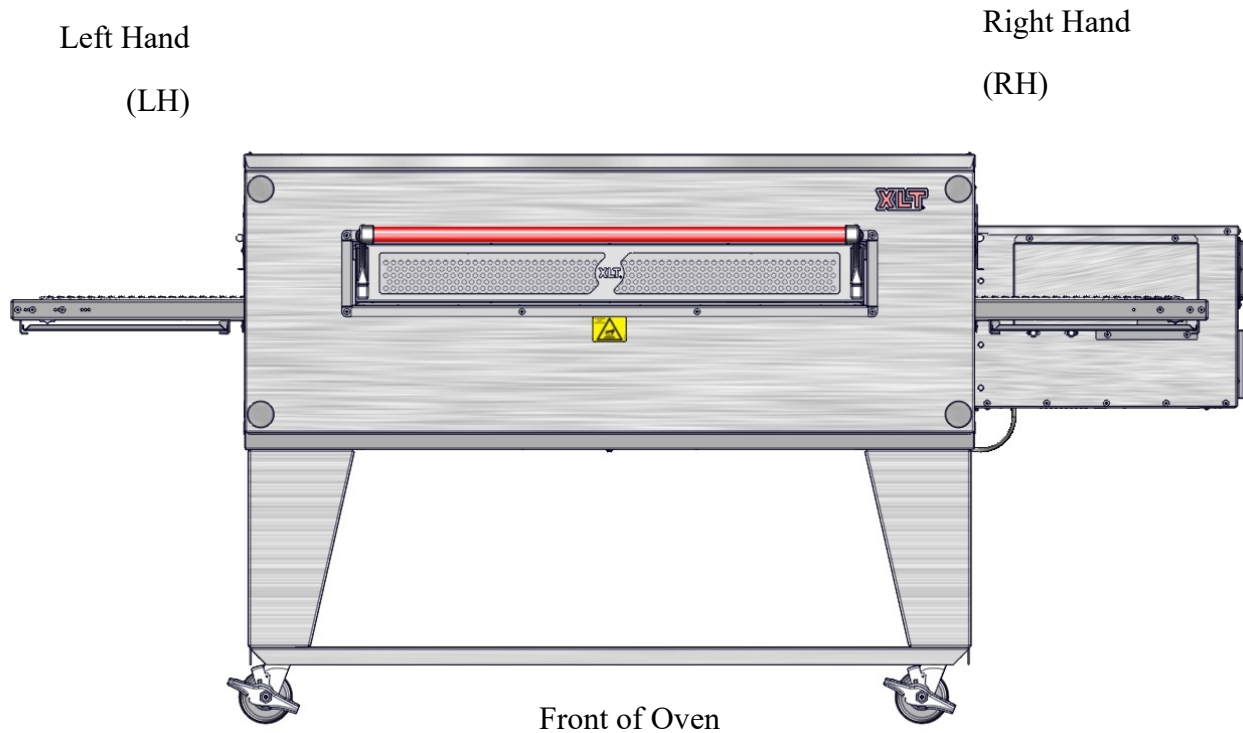



Warranty - US and Canada

Rev L

Approval Date: 01/01/2024

XLT warrants ovens manufactured after January 01, 2024 to be free from any defect in material and workmanship under normal use for seven (7) years from the date of manufacture, and further warrants main fan blades, conveyor shafts, and conveyor bearings for ten (10) years. XLT further warrants all ovens/hoods to be free from rust for ten (10) years from the date the equipment is originally purchased. XLT warrants hoods manufactured after January 01, 2024 to be free from any defect in material and workmanship under normal use for seven (7) years from the date of manufacturer. If the purchase includes a pre-piped Ansul system on both the ovens and hood, the warranty will be increased to ten (10) years on both pieces of equipment. In the event of a part failure, XLT will furnish a replacement part and pay for all labor associated with the replacement of the part. If upon inspection XLT determines that the part is not defective, all incurred costs will be the responsibility of the end user purchaser. This warranty is extended to the original end user purchaser and is not transferable without prior written consent of XLT. Damages are limited to the original purchase price.

DUTIES OF THE OWNER:

- The owner must inspect the equipment and crates at time of receipt. Damage during shipment is to be immediately reported to the carrier, XLT, and documented on the Bill of Lading
- The equipment must be installed and operated in accordance with the Installation and Operation Manual furnished with the unit
- This warranty shall not excuse the owner from properly maintaining the equipment in accordance with the Installation and Operation Manual furnished with the unit
- A copy of the "Initial Start-Up Checklist" must be filled out and returned to XLT when the unit is initially installed, and/or when the unit is removed and installed in another location
- The gas, electric, and HVAC utilities must be connected to the oven and installed by locally licensed contractors
- Failure to contact XLT prior to contacting a repair company for warranty work voids any and all warranties

WHAT IS NOT COVERED:

- Freight damage
- Overtime charges
- Any part that becomes defective because of utility services (power surges, high or low voltages, high or low gas pressure or volume, contaminated fuel, or improper utility connections)
- Any part that becomes defective because of moisture and/or other contaminants
- Conveyor belts
- Filters
- Exhaust Fans
- Light Bulbs
- Painted or Powder Coated surfaces
- Normal maintenance or adjustments
- This warranty shall not apply if the equipment or any part is damaged as a result of accident, casualty, alteration, misuse, abuse, improper cleaning, improper installation, improper operation, natural disasters, or man-made disasters

CLAIMS HANDLED AS FOLLOWS:

- Should any such defect be discovered, XLT must be notified. Upon notification, XLT will arrange for necessary repairs to be made by an authorized service agent. Denial of services upon the arrival of an authorized service agent will release XLT of any and all warranty obligations.





Warranty - International

Rev N

Approval Date: 01/01/2024

XLT warrants ovens manufactured after January 01, 2024 to be free from any defect in material and workmanship under normal use for five (5) years from the date of installation or 63 months from manufacturer date whichever comes first, and further warrants main fan blades, conveyor shafts, and conveyor bearings for ten (10) years. XLT further warrants all ovens/hoods to be free from rust for ten (10) years from the date the equipment is originally purchased. XLT warrants hoods manufactured after January 01, 2024 to be free from any defect in material and workmanship under normal use for five (5) years from the date of installation or 63 months from manufacturer date whichever comes first. If the purchase includes a hood and the ovens both the warranty will be increased to seven (7) years on both pieces of equipment. In the event of a part failure, XLT will furnish a replacement part and pay for all labor associated with the replacement of the part. If upon inspection XLT determines that the part is not defective, all incurred costs will be the responsibility of the end user purchaser. This warranty is extended to the original end user purchaser and is not transferable without prior written consent of XLT. Damages are limited to the original purchase price.

DUTIES OF THE OWNER:

- The owner must inspect the equipment and crates at time of receipt. Damage during shipment is to be immediately reported to the carrier and also to the Distributor/Service Provider
- The equipment must be installed and operated in accordance with the Installation and Operation Manual furnished with the unit
- This warranty shall not excuse the owner from properly maintaining the equipment in accordance with the Installation and Operation Manual furnished with the unit
- A copy of the "Initial Start-Up Checklist" must be filled out and returned to Distributor/Service Provider and to XLT when the unit is initially installed, and/or when the unit is removed and installed in another location
- The gas, electric, and HVAC utilities must be connected to the oven and installed by locally licensed contractors
- Failure to contact the Distributor/Service Provider prior to contacting a repair company for warranty work voids any and all warranties

WHAT IS NOT COVERED:

- Freight damage
- Overtime charges
- Any part that becomes defective because of utility services (power surges, high or low voltages, high or low gas pressure or volume, contaminated fuel, or improper utility connections)
- Any part that becomes defective because of moisture and/or other contaminants
- Conveyor belts
- Filters
- Exhaust Fans
- Light Bulbs
- Painted or Powder Coated surfaces
- Normal maintenance or adjustments
- This warranty shall not apply if the equipment or any part is damaged as a result of accident, casualty, alteration, misuse, abuse, improper cleaning, improper installation, improper operation, natural disasters, or man-made disasters

CLAIMS HANDLED AS FOLLOWS:

- Should any such defect be discovered, the Distributor/Service Provider must be notified. Upon notification, Distributor/Service Provider will arrange for necessary repairs to be made by an authorized service agent. Denial of services upon the arrival of an authorized service agent will release XLT and Distributor/Service Provider of any and all warranty obligations.



Responsibility	Service Company	Owner/ Contractor
Site Survey: Verify electric and gas meter/regulator sizes	X	
Supply wiring from TS1 #R3, R4, R5 to exhaust fan		X
Assembly of new hood per XLT Installation & Operation Manual		X
Suspend XLT Hood from ceiling		X
Weld ducting to XLT Hood		X
Install new exhaust fan on roof		X
Supply power to XLT Hood		X
Install Duct Cover or Valance above XLT Hood		X
Supply wiring from TS1 R3, R4, R5 to exhaust fan		X
Assemble upper and lower shroud assemblies	X	
Install shrouds assembly	X	
Assembly of new ovens per XLT Installation & Operation Manual	X	
Bases assembled and set in place	X	
Supply power to XLT Oven(s)	X	
Ovens moved and stacked with proper lifting equipment	X	
Peel all PVC	X	
Assemble shrouds & brackets to XLT Oven/Hood	X	
Install FS to oven	X	
Connection may require Permit and Code Inspections		X
Relocate Make-Up-Air to enter the room at the ends of the Ovens		X
Start-up per XLT Installation & Operation Manual:	X	
Start-Up Checklist has been filled out per Installation & Operation Manual	X	
Start-Up Checklist must be submitted to XLT to validate Warranty		X



If XLT employees are completing the installation process, they will be considered a Service Company in regards to the above table.



DANGER

Installation of all gas appliances and ventilation exhaust hoods should only be performed by a qualified professional who has read and understands these instructions and is familiar with proper safety precautions. Read this manual thoroughly before installing or servicing this equipment.

Legend from integrated control package electrical schematics:

AL	Alarm, Ignition	M3	Motor, FPPG	TC	Thermocouple
CAP	Capacitor	OMC	Oven Machine Control	TS	Terminal Strip
CB	Circuit Breaker	PS	Power Supply	VFD	Oven Fan Motor Frequency Drive
CS	Current Sensor	PU	Pick-Up	V1	Gas Valve ON/OFF
FLT	Power Filter, EMI	R1	Oven Fan Motor Relay	V2	Gas Valve HI/LOW
FS	Flame Sense	R2	Proving Relay	V3	Gas Valve ON/OFF, Shut-Off
IC	Ignition Control	RTD	RTD, High Limit		
LUI	Large User Interface	S2	Switch, Centrifugal		
M1	Motor, Oven Fan	S3	Switch, High Limit		
M2	Motor, Conveyor	SR	Spark Rod		

Once the oven is plugged into the wall the Oven Machine Control (OMC) Power Light will illuminate.

When the main power button on the Large User Interface (LUI) is pressed for one (1) second:

1. The LUI will illuminate and display actual temperature until set point is reached as well as display belt time.
2. The Oven Fan Motor (M1) located in the Back Wall will run, illuminating the Main Fan Light on the OMC.
3. The Fan (M3) located on the Control Panel will run.
4. The gas valve will receive power, illuminating the Heat Light on the OMC.
5. The conveyor belt will move, illuminating the Conveyor Light on the OMC.
6. The burner will ignite.

The first part (1A) of the Theory of Operation explains how electrical power is delivered to the oven and initial sequences when the main power on the Large User Interface (LUI) is turned on. The second part of the Theory of Operation section explains the function of components in alphabetical order. These components are also listed on the schematic.

- Line voltage for Standard Ovens is assumed to be 120 VAC, 60 Hz.
- Line voltage for World & Australian Ovens is assumed to be 230 VAC, 50 Hz.
- Line voltage for Korean Ovens is assumed to be 220 VAC, 60 Hz.

Part 1A:

Power originates at the electrical connection on the wall or hood is equipped. Line voltage is then carried into the oven through the power cord to the Terminal Strip (TS1). The Neutral line is connected to TS1-3 (TS1-4 on World ovens) and L1 is connected to TS1-4 (TS1-2 on World ovens). From the other side of the TS1, power is carried through the High Limit Switch (S3) and splits at Circuit Breaker (CB1) to go to both the Power Supply (PS) and Oven Fan Motor Relay (R1) or the Variable Frequency Drive (VFD). The PS then converts the line voltage into 24 VDC that is used to power TS2-1 through TS2-3 positions at +24 VDC and TS2-8 through TS2-10 positions at -24 VDC. +24 VDC is distributed to the Oven Controls (OMC1) and (OMC2 if equipped) P10-4 via CB4/5 from TS2-2 and OMC1 P4-2 from TS2-3. These wires are live as long as oven is connected to power on wall. The wires at TS2-1 through TS2-3 and TS2-7 (if there is no hood) are live as long as oven is connected to power on wall.

When the oven is turned on, a relay inside the OMC closes between P4-2 & P4-3, sending 24 VDC out of P4-3 to TS2-6 which distributes power to the Flame Sensor (FS), the FPPG Fan (M3), the Ignition Control (IC) terminal 2 and call for heat IC terminal 4 via the Centrifugal Switch (S2) in Oven Fan Motor (M1) for World ovens and the Current Sensor (CS) for standard ovens. The IC then starts the trial for ignition. The OMC P11-1 will also send low voltage to the R1 or the Oven Fan Motor Relay (VFD World, Korea, and Australia Only). When R1 closes, line voltage is applied from R1-2 to M1. OMC P11-2 will ground V2 to open the high flame valve. If the oven is used with an XLT Hood the jumper at Molex Connector (MC3) is removed and +24 VDC is sent to the hood. A relay in the hood will control the oven operation as long as the LUI had the Remote Switch Function turned on.

Legend from discrete control package electrical schematics:

AL	Alarm, Ignition	M2	Motor, Conveyor	SSR	Solid State, Valve Control
CAP	Capacitor	M3	Motor, FPPG	TC1	Temperature Control
CB	Circuit Breaker	PS	Power Supply	TC2	Temperature Control
CC	Conveyor Control	PU	Pick-Up	TC	Thermocouple
CD	Conveyor Display	R1	Oven Fan Motor Relay	TS	Terminal Strip
CS	Current Sensor	R2	Proving Relay	V1	Gas Valve ON/OFF
FLT	Power Filter, EMI	S1	Switch, Rotary	V2	Gas Valve HI/LOW
FS	Flame Sense	S2	Switch, Centrifugal		
IC	Ignition Control	S3	Switch, High Limit		
M1	Motor, Oven Fan	SR	Spark Rod		

When the main power rotary switch is turned to the “on” position;

1. The Temperature Control(s) (TC1 & TC2) and Conveyor Control(s) (CC) will illuminate and display actual temperature until set point is reached as well as display belt time.
2. The Oven Fan Motor (M1) located in the Back Wall will run.
3. The Fan (M3) located on the Control Panel will run.
4. The Gas Valve(s) (V1 & V2) will receive power.
5. The conveyor belt will move.
6. The burner will ignite.

The first part (1B) of the Theory of Operation explains how electrical power is delivered to the oven and initial sequences when the main power is turned on. The second part of the Theory of Operation section explains the function of components in alphabetical order. These components are also listed on the schematic.

- Line voltage for Standard Ovens is assumed to be 120 VAC, 60 Hz.
- Line voltage for World & Australian Ovens is assumed to be 230 VAC, 50 Hz.
- Line voltage for Korean Ovens is assumed to be 220 VAC, 60 Hz.

Part 1B:

Power originates at the electrical connection on the wall or hood is equipped. Line voltage is then carried into the oven through the power cord to the Terminal Strip (TS1). The Neutral line, and L1 are connected to TS1. From the other side of the TS1, power is carried through the High Limit Switch (S3) and splits at Circuit Breaker (CB1) to go to both the Power Supply (PS) and Oven Cool-Down Relay (R1). The PS then converts the line voltage into 24 VDC that is used to power TS2 positions at +24 VDC and at -24 VDC. +24 VDC is distributed to the Temperature Control(s) (TC1&2), Conveyor Control (CC), Cooling Fan (M3), Flame Sense (FS), and Gas Valve (V2). For Worlds, the same voltage is distributed to the Ignition Control (IC). If the oven is used with an XLT Hood the jumper at Molex Connector (MC3) is removed and +24 VDC is sent to the hood. A relay in the hood will control the oven operation as long as the LUI had the Remote Switch Function turned on.

Some ovens, depending on the date of manufacture, may include a 120VAC ignition control package. This works similar to the 24VDC ignition control, with the exception of the utilization of an additional (R2) relay used to receive the 24VDC from P4-3 and distributes the necessary 120VAC to the 120VAC Ignition Control. OMC P11-2 will ground V2 to open the high flame valve.

Part 2:

AL - The Ignition Alarm is available on the Australian and Korean models. When the Ignition Control (IC) goes into ignition lockout and pin1 is grounded the alarm will begin flashing and beeping. The alarm receives +24 VDC from the TS2-1 on the master control box and if it is a dual burner TS3-1 on the secondary box. Cycle power on the oven to reset alarm.

CAP - The Capacitor is physically mounted inside the Control Box but wired to the externally mounted M1. The M1 is a Permanent Split Capacitor (PSC) motor. PSC means a capacitor motor in which the starting capacitor and the auxiliary winding remain in the circuit for both starting and running. The CAP is a 30.0 uF +/- 6% 370VAC/B 50/60 Hz.

CB - Circuit Breakers are used to protect electrical components. The current value is printed on the front of all breakers. If a CB is tripped, eliminate the cause and press the front to reset.

CC- Conveyor Control, for discrete control package, provides rotation and speed of the conveyor.

CD - Conveyor Display, for discrete control package, displays the time of the conveyor.

CS - The Current Sensor detects electrical current (AC) in a wire, and generates a signal proportional to it. The generated signal is analog voltage and then sends it to the OMC. This monitors the condition of the oven fan motor controls the call for heat signal.

FLT 1 - This is an inline filter used in world ovens. The filter is placed in series with the line voltage being supplied to the oven. The filter is used to reduce Electromagnetic Interference created by our equipment and back-feeding it into other appliances. The Electromagnetic Compatibility (EMC) filter in the gas oven uses capacitors to inhibit direct current while permitting alternating current. The filters also use inductors which redirect high voltages and high frequencies by dissipating them to ground. Filters should always be grounded to the oven.

FS - The Flame Sensor consists of a plastic housing and a flame sensor mount. The FS utilizes 24 VDC which originates at TS2-5. When the oven is turned on this terminal receives voltage. The negative line is supplied via the TS2-9. When flame is present, a blue wire sends a 6.75 μ A signal from the connector to IC-10. The minimum flame sensitivity signal to maintain operation is 0.7 μ A. The sensor visually looks at the flicker rate and the UV characteristics of the flame. If either

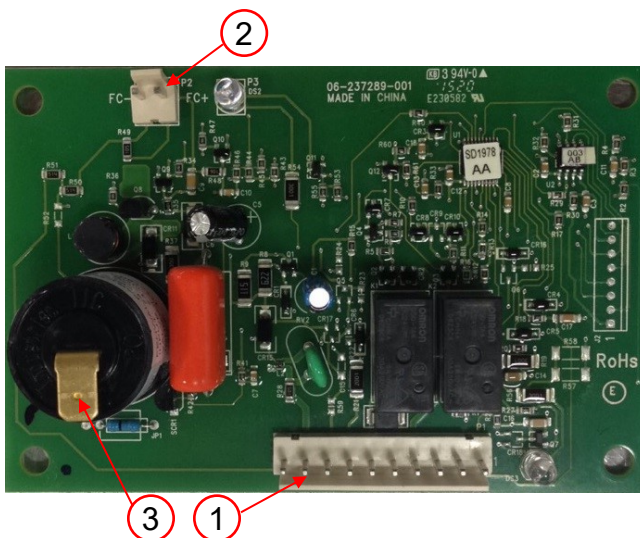

1) P1

- 1) Alarm (Australian and Korean models only)
- 2) +24 VDC In
- 3) Not Used-Manual Reset
- 4) Call For Heat
- 5) Ground In
- 6) +24 VDC Sent To V1
- 7) Not Used-Digital Output
- 8) Not Used
- 9) Burner Ground
- 10) Signal Wire To Flame Sensor

2) P2- Not Used
3) Spark Terminal

of these do not appear the sensor will not send current to the IC. The ignition will continue through its process until lockout.

IC - The Ignition Control is powered by 24 VDC. The IC has two +24 VDC inputs; 1) from the OMC via the TS2, and 2) a call for heat from the OMC via S2 which is mounted in M1. This will turn a green LED on indicating IC has power and a call for heat. When the IC receives a call for heat, it initiates a pre-purge lighting sequence. A red LED will blink once after about two (2) or three (3) seconds to give notification that the lighting sequence has started. After about thirty (30) seconds, two (2) events occur; 1) a high-voltage electrical signal will be sent to the Spark Rod (SR) from the Spark Terminal. The high voltage jumps across a gap in the SR creating a spark that can be heard, although the IC only produces this spark for four (4) seconds. 2) A VDC (+) will be sent from terminal IC6 to Gas Valve V1-V2 via CB2 and CB3. The V1-V2 valve will open, allowing fuel to flow into the burner. When the two events occur, spark and fuel flow, ignition will occur. When flame is sensed by the FS, a DC signal is sent to IC10. The IC uses this DC current

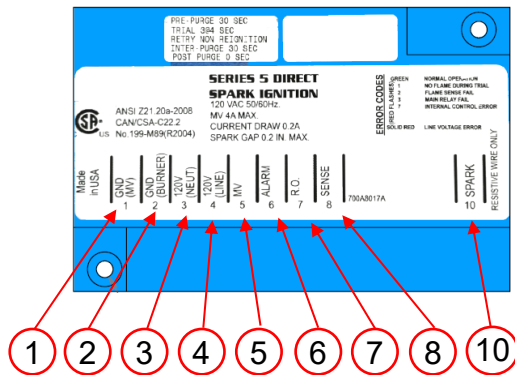

- 1) GND (MV)
- 2) GND (Burner)
- 3) 120V (Neutral)
- 4) 120V (Line)
- 5) MV
- 6) Alarm
- 7) R.O.
- 8) Sense
- 10) Spark

to prove ignition. A minimum of 0.7 μ A DC is required to maintain operation. If the Burner fails to light, the IC will reattempt ignition two (2) more times before the LED will flash three (3) times, repeatedly, going into lockout.

IC - Some ovens, depending on the date of manufacture, may include a 120VAC ignition control package. The Ignition Control is powered by 120VAC. This works similar to the 24VDC ignition

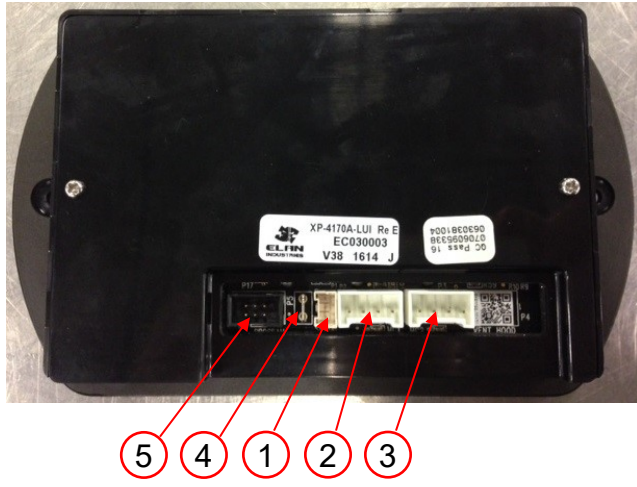

- 1) P1- Not Used
- 2) P2- RS-485 Cable To OMC1
 - 1) +5V
 - 2) 485-
 - 3) 485+
 - 4) Ground
- 3) P3- RS-485 Cable To OMC2
 - 1) +5V
 - 2) 485-
 - 3) 485+
 - 4) Ground
- 4) P5- Ground
- 5) P17- Elan Programming

control, with the exception of the utilization of an additional (R2) relay used to receive the 24VDC from P4-3 and distributes the necessary 120VAC to the 120VAC Ignition Control. OMC P11-2 will ground V2 to open the high flame valve.

LUI - The Large User Interface (LUI) is powered by the OMC by the RS 485 cable. The main power button is located on the front face of the LUI. The conveyor(s) and temperature of the oven is controlled through the LUI. Factory settings are programmed for the oven size, VFD/Non VFD, cool down mode, and Gas/Electric, etc. For a Standard Oven it will also display the main fan amps. The LUI will display error messages and maintenance alarms. There are twelve (12) menu presets for predetermined time and temperature settings. The screen can be locked to prevent unwanted changes.

M1 - The Main Motor for standard ovens is a single phase, capacitor run motor and has an internal centrifugal switch (S2) in World ovens. The motor is dual voltage and reversible. The voltage to power the motor comes from the R1-2. For world ovens M1 is a three (3) phase inverter rated motor with an internal S2. It gets power from a variable frequency drive (VFD) which is then turned on by the OMC. The main motor (M1) will continue to operate for approximately thirty (30) minutes or until the oven temperature is less than 225°F/108°C (+/-3°F/2°C) after the oven is turned off. There are no user serviceable parts in the motor, and the bearings are permanently lubricated.

M2 - The Conveyor Motor is a brushless 24 VDC gear motor. The motor receives current from the OMC through three (3) wires; 1) A “W” phase, 2) a “V” phase, and 3) an “U” phase. They carry between 18 to 24 VDC. Each wire is energized by the OMC in sequence to provide power to the individual stator coils which, in turn, provide motor rotation. To determine the rotor position and send this position to the controller, three (3) Hall Effect switches are utilized. They read the rotational information from a disc mounted on the rotor assembly. This information is transmitted to the OMC by three (3) wires; 1) an “U” phase pole signal output, 2) a “V” phase pole signal output, and 3) a “W” phase pole signal output. These are located in a plug that inserts into the OMC1 or OMC2. There are two (2) additional wires in this plug; 1) a wire which is voltage for the pole sensor, and 2) a wire that is ground. The OMC, using an internal logic circuit, energizes the stator coils to provide proper rotation and sets the energization (phase) timing to obtain the desired belt speed set on the controller. The motor drives an integral gear box that reduces the motor output speed to give the correct travel time to the conveyor belt. The integral gear box is sealed and permanently lubricated with grease. The ratio is 200:1. This motor contains no serviceable parts. The OMC will detect if the conveyor belt has a jam by monitoring the rotor signal. If the signal falls more than 25% below the expected rate a jam is detected. This action will stop the conveyor and display an alarm on the LUI. To reset the alarm press and hold the TIME key for ten (10) seconds.

M3 - The Flow Path Pressure Generating fan supplies combustion air for the Burner. It is controlled by turning on and off the main power button. A filter is provided to ensure clean air. There are no user serviceable parts in the motor, and the bearings are permanently lubricated.

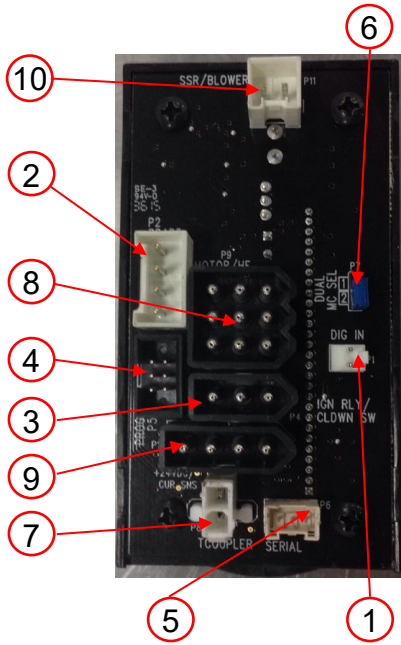

- 1) P1- Not Used - Digital Input
- 2) P2- RS-485 Cable To LUI
 - 1) +5V
 - 2) 485-
 - 3) 485+
 - 4) Ground
- 3) P4-Molex provided with harness
 - 1) +24 Remote Switch
 - 2) +24 Power (In) Switch
 - 3) Relay +24 Switched (Out)
- 4) P5- Elan Programming
- 5) P6- Elan Serial Port
- 6) P7- Jumper For OMC 1 or 2
- 7) P8- Thermocouples
 - 1) Red (-)
 - 2) Yellow (+)
- 8) P9- Conveyor Motor
 - 1) Motor SA
 - 2) Motor SB
 - 3) Motor SC
 - 4) Hall +5V
 - 5) Hall HC+
 - 6) Hall HB+
 - 7) Hall HA+
 - 8) Ground
 - 9) Not Used
- 9) P10-Molex provided with harness
 - 1) Current Sensor
 - 2) Current Sensor
 - 3) 24 VDC(-) Main Power
 - 4) 24 VDC(+) Main Power
- 10) P11-Molex provided with harness
 - 1) +24 VDC To R1/VFD
 - 2) -24 VDC Ground to Gas Valve V2

OMC - The Oven Machine Control reads selections or parameters from the LUI. It holds the logic for the conveyor controls and the temperature controls. The OMC will turn on or off the gas valve (V2), start and stop M1, send the call for heat signal, read the thermocouple and monitor the current sensor.



- 1) CN2- 24VDC
 - 1) +24 VDC Main Power To OMC
 - 2) +24 VDC
 - 3) -24 VDC Ground To IC
 - 4) -24 VDC Ground To TS2
- 2) CN1- Line Voltage
 - 1) Neutral
 - 2) Not Used
 - 3) Line Voltage

PS - The Power Supply rectifies line voltage to 24 VDC, and supplies power to the OMC, IC, FS, and S2.

PU - The Pick-Up is physically mounted within M2 and utilizes hall effect technology integral to the M2 to monitor the rotation speed. The hall effect signal is transmitted to the OMC, which converts it into linear travel speed of the conveyor.

R1 - The Oven Fan Motor Relay is used as a remote switch to handle the higher amp load of M1. It is a Single Pole Double Throw (SPDT) relay, which is an electrically operated switch. It uses an electromagnet to operate a switching mechanism.

RTD - The Resistive Thermocouple Detector monitors the air temperature inside the bake chamber. The RTD wire is a pure material, typically platinum, nickel, or copper. The material has an accurate resistance/temperature relationship which is used to provide an indication of temperature.

S1 - The Rotary Switch is a toggle switch for distributing power from the supply to the oven for operation.

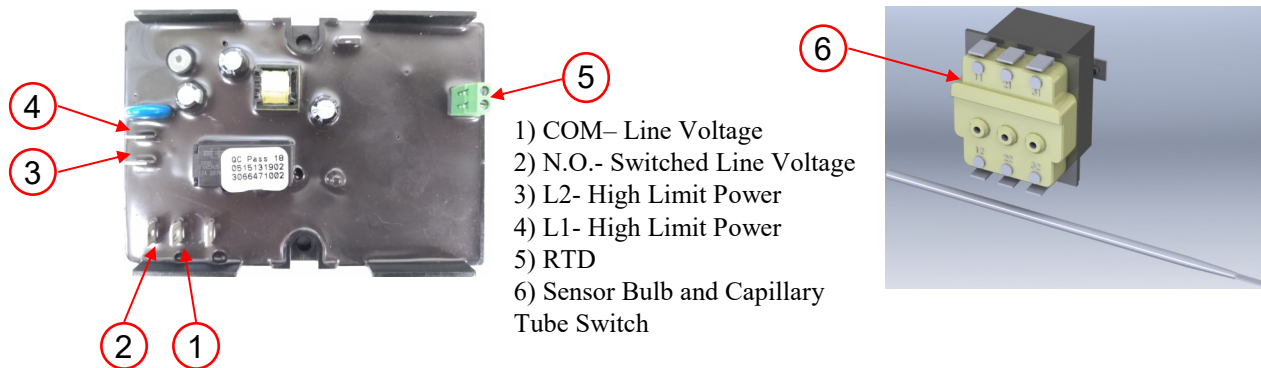

S2 - World Ovens - The Centrifugal Switch is a SPDT switch physically mounted inside M1. When M1 comes up to full speed, S2 closes and sends a 24 VDC signal to the IC. It functions as a safety feature to prevent burner operation if the M1 fails to rotate.

S3 - Standard Ovens - The High Limit Switch for standard ovens is a bi-metal, normally closed (NC), Single Pole Single Throw (SPST), switch physically mounted in the side panel of the Bake Chamber. Its purpose is to provide fail safe operation. If the temperature of S3 exceeds 600°F/316°C it opens and interrupts line voltage to all components.

(NOTE: Based On Date Of Mfg, See S3 Options Below)

S3 - World Ovens- The High Limit Switch is an electronic, SPST switch. Its purpose is to provide fail safe operation. If the RTD temperature exceeds 650°F/343°C the red LED will turn off and S3 opens to interrupt line voltage to all components. In order to reset the S3, you must unplug the main power supply.

S3 - World Ovens- The High Limit Switch is a sensor bulb and capillary tube switch. Its purpose is to provide fail safe operation. If the bulb temperature exceeds 689°F/365°C, S3 opens to interrupt line voltage to all components. In order to reset the S3, you must decompress the button on the component after the device has cooled down.

SR - The Spark Rod consists of a copper-clad metal mounting plate, and an electrode encapsulated in ceramic insulation. The insulated electrode has a 1/4" male spade welded to it. This spade connects to the Spark Terminal on the IC via a spark wire. The end of this rod is positioned near the burner tube in such a way so as to create a small gap. When the high-voltage signal from the IC reaches the gap, it is forced to jump the gap resulting in a spark.

SSR - 10A solid state relay, used in conjunction with the discrete temperature control package.

TC - The thermocouple is a type K. It consists of two different conductors that produce a voltage proportional to a temperature difference between either end of the pair of conductors. The TC is connected to P8-1 and P8-2 on the OMC. The millivolt signal is used to display the actual temperature.

TC 1 & 2 - Temperature control components, used in the discrete control package, to monitor and control the set point and actual temperature.

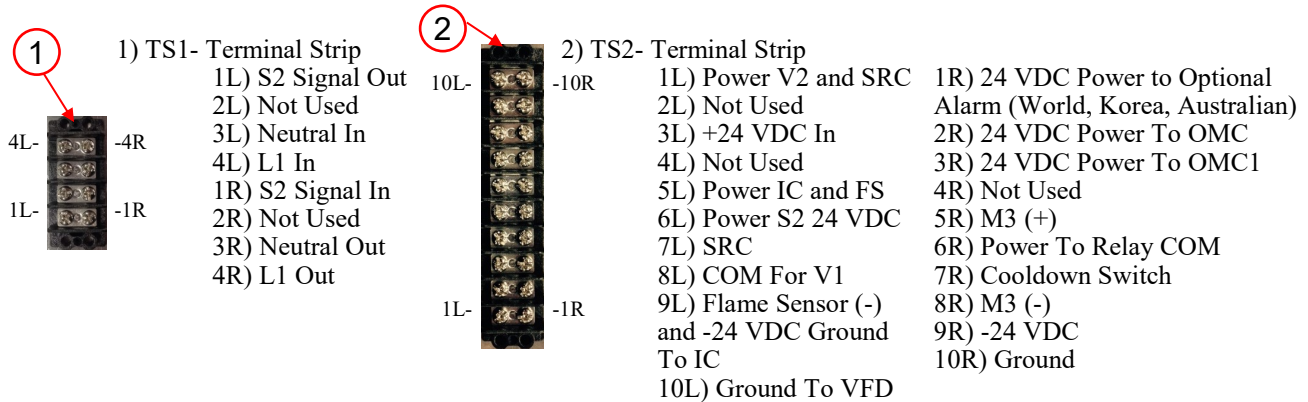

*Above image references Right Hand Control (RH) ovens.

TS 1 & 2 - These are terminal strips, that serve as a connection point for wires.

V1-V2 - The Gas Valve consists of two (2) solenoid valves. V1 is open continuously during burner operation, regardless of either actual or set point temperature values. V2 is a Hi/Low valve, and is controlled by P11-2 on the OMC. There are two (2) brass fuel pressure testing ports; the upper port is used for incoming pressure, while the lower port is used for high-bias pressure. There is a regulator on the side of the valve to adjust the High-bias pressure.

V3 - The shut-off valve is only in the Australia Control box. When M1 is receiving power from the VFD, the relay at VFD-R1 closes sending +24 VDC to V3, which opens the valve.

VFD - The Variable Frequency Drive converts incoming single phase power of 50 Hz or 60 Hz power so the ovens fan can run at the customer desired RPM's, not to exceed 65 Hz. The VFD converts the AC supply voltage to DC and then converts the DC to a suitable three-phase frequency source for M1. The VFD is turned on via the OMC P11-1. A complete VFD manual can be found at www.xltovens.com.

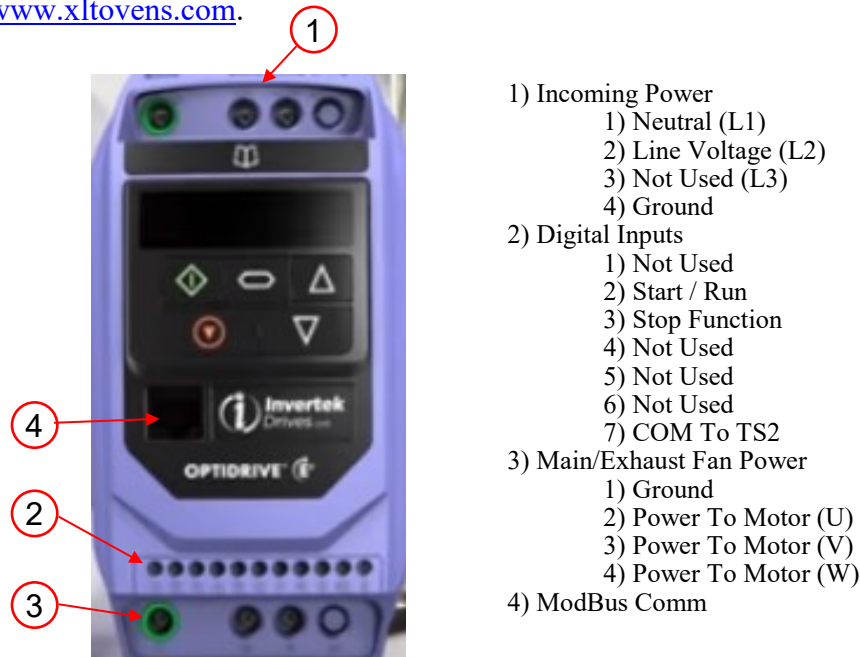

Legend from electrical schematics:

CB	Circuit Breaker	M3	Motor, Cooling Fan	S	Switch
HMC	Hood Machine Control	PS	Power Supply	SRC	Switch Relocation Cord
HUI	Hood User Interface	R1	Fire Suppression Relay	TS	Terminal Strip
LT	Lamp	R2	Fire Suppression Time Delay Relay	VFD	Variable Frequency Drive
M1	Motor, Exhaust Fan		Relay		
M2	Motor, Cooling Fan	REC	Receptacle		

When any one of the three oven buttons on the Hood User Interface (HUI) are touched (capacitive touch);

1. The Exhaust Fan Motor (M1) located on the roof will run.
2. The ovens associated with the corresponding buttons will turn on.

The first part of the Theory of Operation explains how electrical power is delivered to the hood and initial sequences when the HUI is turned on. The remainder of the Theory of Operation section explains the function of components in alphabetical order. These components are also listed on the schematic.

Part 1:

Power for the hood originates at the building's electrical service panel. A total of four (4) circuits are required; one (1) is a single phase high voltage circuit for Variable Frequency Drive (VFD)/Fan circuit that connects to TS-1 and TS-2, and the remaining three (3) circuits are single phase low voltage minimum 20A circuits for each oven that connects at the Hood Machine Control (HMC) P3-1, P3-5, and P3-9 for line side, and neutral will connect at P3-3, P3-7, and P3-11.

The HUI mounted on the hood controls the lighting, VFD activation, Make Up Air (MUA) activation and oven function. When the HUI Light button is touched a relay is closed and voltage goes to the lights. When ovens are installed with a hood, the Switch Relocation Cord (SRC) effectively eliminates the main power button located on the oven and transfers control to HUI buttons on the hood. When HUI controls are touched a communication signal is sent to the VFD via ModBus signaling it to turn on to a set frequency. At the same time a relay will allow line voltage to be carried through the SRC to the oven activating it. When the HUI is activated the MUA will turn on. The VFD has a built in power supply that is wired to TS1-1L. This puts the VFD in run mode so whenever a power loss is sensed the VFD will start back up in run mode once power is restored. The NO switch in the fire alarm system in the building needs to be connected to TS1-R9 and TS1-R10. When the alarm is activated 24 VDC from TS1-R9 will return from the fire alarm system to TS1-R10 then to HMC P8 to turn off lights, cooling fans, HUI, MUA, shut down ovens and making both relays R1 & R2 switch from NC to NO, causing the VFD to run at 60 Hz.

Part 2:

CB - Circuit Breakers are used to protect electrical components. If a CB is tripped, eliminate the cause and press the front to reset.

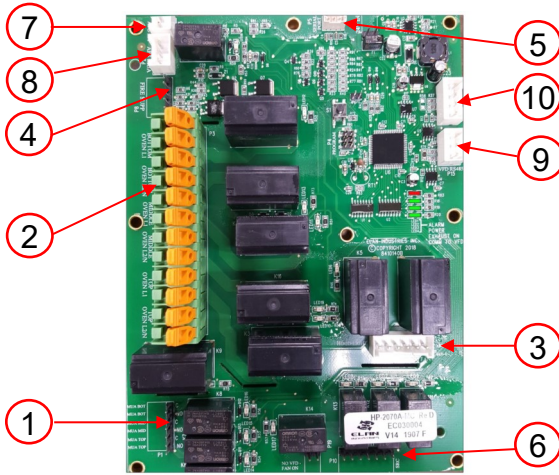

- 1) P1- Dampers
 - 1) MUA Top
 - 2) Not Used
 - 3) MU A Middle
 - 4) Not Used
 - 5) MUA Bottom
 - 6) Common
- 2) P3- Oven Power
 - 1) Bottom Oven L1
 - 2) Not Used
 - 3) Bottom Oven L2/N
 - 4) Not Used
 - 5) Middle Oven L1
 - 6) Not Used
 - 7) Middle Oven L2/N
 - 8) Not Used
 - 9) Top Oven L1
 - 10) Not Used
 - 11) Top Oven L2/N
 - 12) Not Used
- 3) P7- Lights/Cooling Fans
 - 1) By Installer
 - 2) Light 1
 - 3) Light 2
 - 4) To PS CN2-3
 - 5) +24 VDC To Cooling Fan
 - 6) +24 VDC To Cooling Fan
- 4) P8- Fire Suppression
 - 1) To TS1-10L
 - 2) To R1-1
 - 3) Not Used
 - 4) Not Used
 - 5) Not Used
- 5) P9- Power
 - 1) +24 VDC Power Supply CN2-1
 - 2) -24 VDC Power Supply CN2-4
- 6) P10- Switch Relocation Cord
 - 1) Bottom Oven
 - 2) Bottom Oven
 - 3) Middle Oven
 - 4) Middle Oven
 - 5) Top Oven
 - 6) Top Oven
 - 7) Not Used
- 7) P13- APS Ex
 - 1) TS2-4R
 - 2) TS2-5R
- 8) P15- VFD
 - 1) TB2
 - 2) TB1
 - 3) Not Used
- 9) P20- APS MUA
 - 1) TS2-3R
 - 2) TS2-2R
 - 3) TS2-1R
- 10) P25- Cable to HUI
 - 1) Black
 - 2) Orange
 - 3) White
 - 4) Red

HMC - The Hood Machine Control is a printed circuit board that has all the relays to control these functions; oven activation SRC, MUA activation, VFD activation, monitors the air proving switches, and lighting activation. The HMC receives a continuous 24 VDC power source provided the CB1 breaker is on. This component also has independent relays to control oven power for fire suppression. If a signal from the fire system is received the oven(s) and lighting power is discontinued and the VFD will run at full speed. For a World installation, sail switch monitoring is available just by answering some questions through factory mode programming. The HMC will also program the PowerFlex 4M VFD each time the CB1 breaker is turned on. ModBus communication is used to change the frequency the VFD runs at depending on the number of ovens used. Error messages will appear on the screen to help with troubleshooting. The screen will flash and beep indicating a error has occurred, the alarm button can cancel this for two (2) hours. If error has not been fixed beeping will return. The HMC has filter cleaning reminders available.

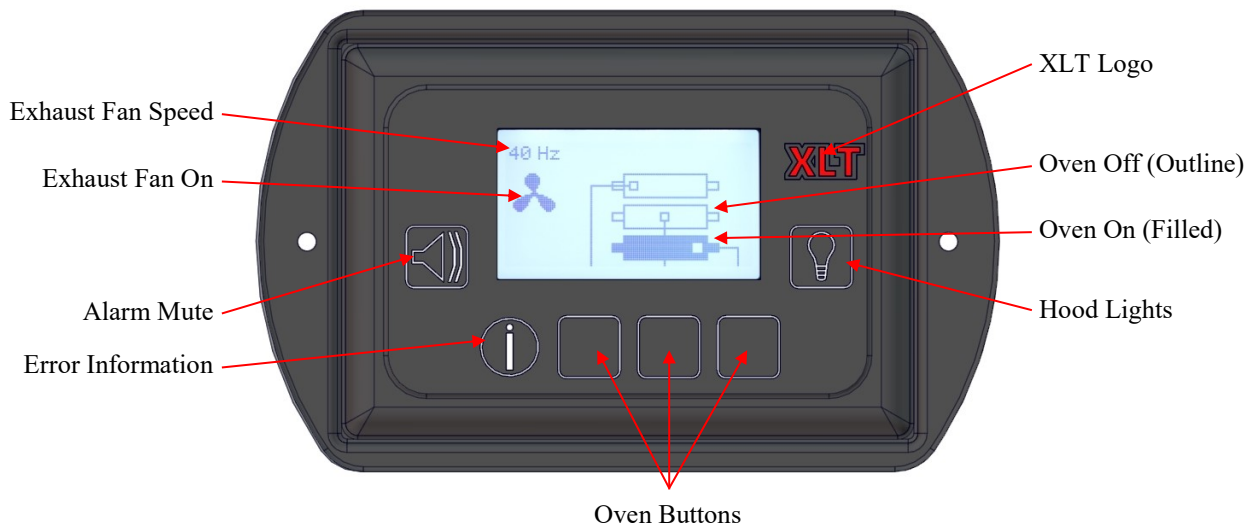

HUI - Hood User Interface contains the factory settings so that the hood will operate with the correct hertz when the correct oven size and number of ovens are selected. The factory settings also contain a selection for a VFD, Non VFD, type of MUA activation, and for a World installation. A beeping sound and the display will flash if an alarm occurs. An error message will display at top of screen on HUI. Touching the “I” button will give a brief description of how to correct the error. Touching the “Light Bulb” button will turn the light on and off inside the hood.

Touching the “Silver Square” buttons will turn each oven on or off and sequence the operation of the VFD and the MUA circuits. RS-485 cable supplies power and communication between the HUI and HMC.

LT1 & LT2 - These are light bulbs at each end of the hood that illuminate when the HUI hood lights button is pressed. When pressed again the lights turns off.

M1 - The Exhaust Fan Motor is a 3-phase, direct drive motor. In normal operation, it is powered by the VFD and its RPM will vary as the frequency from the VFD varies. There are no user serviceable parts in the motor, and the bearings are permanently lubricated.

M2 & M3 - The Cooling Fan Motor is a 24 VDC, direct drive motor. In normal operation, it is powered through HMC. These fans are used to keep the control box for the hood cool. There are no user serviceable parts in the motor, and the bearings are permanently lubricated.

PLUG 1, 2, & 3 - These are circular electrical plugs on one end of the SRC. The plugs connect to Receptacles 4, 5, & 6 on the back of the hood. The other end of the SRC plugs into the oven wire harness, and eliminates the power button supplied on the oven. Conversely, when the HUI on the hood is turned off, the corresponding oven is turned off as well.



- 1) CN2- 24VDC
 - 1) +24 VDC Power To HMC
 - 2) +24 VDC Power to Fire Suppression
 - 3) -24 VDC Power To HMC
 - 4) -24 VDC Ground
- 2) CN1- Line Voltage
 - 1) Neutral
 - 2) Not Used
 - 3) Line Voltage

PS - The Power Supply rectifies line voltage to 24 VDC, and supplies power to the HMC, cooling fans, and fire suppression.

R1 - Is a Single Pole Double Throw (SPDT) relay, which is an electrically operated switch, an electromagnet is used to operate a switching mechanism. Voltage is supplied from TS1-9R to AN-SUL agent box. Once the fire alarm is activated voltage returns to TS1-10 over to HMC P8. That same voltage continues to R1-1 activating the coil in the relay, causing the contacts in the relay to switch from NC to NO. This will switch 24 VDC from terminal 6 to terminal 5 on the VFD causing the M1 to operate at 60Hz.

R2 - Is a SPDT time delay relay, which is an electrically operated switch, an electromagnet is used to operate a switching mechanism. Voltage continues from R1-6 to R2 via the red wire activating the coil in the relay, causing the contacts in the relay to switch from NC to NO after one second has expired. This action delays the application of the voltage on terminal 5 on the VFD.

REC 1, 2, & 3 - These are electrical receptacles, which supply line voltage for the ovens. Each receptacle should have a 20A dedicated breaker supplied from the buildings electrical panel. Line voltage to each receptacle is supplied via HMC P3. If the fire alarm is activated P3 will disrupt line voltage being supplied to receptacles shutting the oven(s) off.

REC 4, 5, & 6 - These are circular electrical receptacles mounted on the back of the hood. The SRC connects into these. This deactivates the main power button located on the oven and relocates the operation of it to the HUI. This capacitive touch (NO) button is located on the front of the hood and controls the lights.

TS 1 & 2 - These are terminal strips, that serve as a connection point for wires.



- 1) Incoming Power
 - 1) Neutral
 - 2) Line Voltage
 - 3) Not Used
 - 4) Ground
- 2) Not Used-VFD Relay
- 3) Digital Inputs
 - 1) Stop Function
 - 2) Start / Run
 - 3) Not Used
 - 4) COM To TS2
 - 5) Not Used
 - 6) Not Used
- 4) Exhaust Fan Power
 - 1) Power To Motor
 - 2) Power To Motor
 - 3) Power To Motor
 - 4) Not Used
 - 5) Not Used
- 5) ModBus Comm

VFD - The Variable Frequency Drive converts the AC supply voltage to DC and then converts the DC to a suitable three-phase frequency source for M1. Incoming power connects to terminals L1 & L2. M1 connects to terminals T1, T2, & T3 through TS1. The HMC sends the command to the ModBus to set the frequency for the combination of ovens selected. The VFD can receive a signal from the fire suppression system to command the drive to run at 60 Hz. A complete manual can be found at www.xltovens.com.



- 1) Incoming Power
 - 1) Neutral (L1)
 - 2) Line Voltage (L2)
 - 3) Not Used (L3)
 - 4) Ground
- 2) Digital Inputs
 - 1) Not Used
 - 2) Start / Run
 - 3) Stop Function
 - 4) Not Used
 - 5) Not Used
 - 6) Not Used
 - 7) COM To TS2
- 3) Main/Exhaust Fan Power
 - 1) Ground
 - 2) Power To Motor (U)
 - 3) Power To Motor (V)
 - 4) Power To Motor (W)
- 4) ModBus Comm

(NOTE: VFD based on Date Of Mfg.)

Mechanical Function

If your oven does not function properly, please verify the following conditions:

1. Verify that the power cord to the oven is connected and/or plugged in if equipped with a plug and receptacle.
2. Check all circuit breakers on the oven control panel and on the back of the control box to ensure they have not been tripped.
3. Check to see that the circuit breakers in the building electrical service panel have not been tripped or turned off.
4. Check the manual gas valve to verify that it is turned on completely. The handle on the valve should be parallel with the gas piping when the valve is turned on, and the handle will be perpendicular with the gas piping when the valve is turned off. Also remember that anytime the gas hose has been disconnected it will take time to purge the air from the inlet gas pipe.
5. Verify that the oven is supplied with gas by disengaging and reengaging the quick-disconnect fitting on the gas hose.
6. Check to see that the oven is fully assembled. All of the fingers must be properly installed. Incorrect or incomplete finger placement can cause a “windy” condition that can cause the burner not to light.
7. Gas line size and pressure must be adequate to support total BTU requirements with all appliances in store turned *on*. Refer to the “Oven Gas Requirements” section of this manual.
8. In the case of the oven not lighting properly. Turn off the oven and wait approximately thirty (30) seconds or until the fan stops spinning and turn the oven back on.
9. (World Installations) If using the Sail Switches check the HUI for error messages relating the Sail Switch sequencing.



Proceed with caution and read the following instructions carefully when unplugging the units.

Hard Reset

If your oven still does not function properly, perform a hard reset. First, power down the unit then unplug the unit from all electrical power. Leave the unit unplugged for one (1) minute. Once this is done, plug the unit back in and turn on the power.

LUI Service Error Codes

Display Alarm	MC LED	Error Determination	Troubleshooting
Oven Probe	Alarm LED on. Flash HEAT LED. All other LEDs operate as normal.	Temp Sensor Error, Open or Short. Temp < 40°F(4°C) or >700°F(371°C)	Perform a hard reset. If error still exists, contact XLT.
Ignition Error	Alarm LED on. Flash HEAT LED. All other LEDs operate as normal.	From Ignition enable (run) signal, if oven doesn't see 25°F (-4°C) temp rise in three (3) minutes. If restart (actual temp within 50°F (10°C) of set point) error timing ten (10) minutes.	Check to see if gas hose is connected. Next, is exterior gas valve on? If yes, perform a hard reset. If no, turn gas valve on. If error still exists, contact XLT.
Over Temp	Alarm LED on. Flash HEAT LED. All other LEDs operate as normal.	Temp is 50°F (10°C) over set point for period > one (1) minute. If user adjusts set point lower, inhibit alarm until new set point is reached.	Perform a hard reset. If error still exists, contact XLT.
Under Temp	Alarm LED on. Flash HEAT LED. All other LEDs operate as normal.	Once set point is reached, the Actual is 15°F (-9°C) under set point for more than thirty (30) minutes. If user adjusts set point, reset timer.	Check to see if gas hose is connected. Next, is exterior gas valve on? If yes, perform a hard reset. If no, turn gas valve on. If error still exists, contact XLT.
Over Speed	Alarm LED on. Flash CONVEYOR LED. All other LEDs operate as normal.	Speed > thirty (30) seconds fast Duration vs. Set Point	Perform a hard reset. If error still exists, check LUI settings. If settings are correct, perform a pan test to confirm settings. If error still exists, contact XLT.
Under Speed	Alarm LED on. Flash CONVEYOR LED. All other LEDs operate as normal.	Speed > thirty (30) seconds fast Duration vs. Set Point	Check drive chain and sprocket to verify proper working condition. Perform a hard reset. If error still exists, check LUI settings. If settings are correct, perform a pan test to confirm settings. If error still exists, contact XLT.
Software Error	Alarm LED flash. All other LEDs off.	Internal Software Error	Check for pinched wires. Perform a hard reset. If error still exists, contact XLT.
EEPROM Error	Alarm LED flash. All other LEDs off.	Bad Checksum	Perform a hard reset. If error still exists, contact XLT.
Key Short	Alarm LED flash. All other LEDs off.	Any Key Shorted > one (1) minute.	Clean LUI screen. Verify LUI software is version 50 (v50) or later in Tech Mode. Perform a hard reset. If error still exists, contact XLT.
Comm Error	Alarm LED flash. All other LEDs off.	Internal software error	Perform a hard reset. If error still exists, contact XLT.
Main Fan Low Amps	Alarm LED on. Flash FAN LED. All other LEDs operate as normal.	Amps below min level per Main Fan Amp level table for ten (10) seconds.	Perform a hard reset. If error still exists, contact XLT.
Main Fan High Amps	Alarm LED on. Flash FAN LED. All other LEDs operate as normal.	Amps below max level per Main Fan Amp level table for ten (10) seconds.	Check CBI to see if it has tripped. If yes, reset CBI. If no, perform a hard reset. If error still exists, contact XLT.

If your oven still does not function properly, XLT has qualified customer service personnel that can provide assistance on any type of XLT equipment problem you may experience. Customer Service is available 24/7/365 at 888-443-2751, or visit www.xltovens.com.



Removing the hood VFD cover panel exposes high voltage. Proceed with caution and read the following instructions carefully.

Initial troubleshooting of the hood

1. Remove panel covering VFD to check and see if the circuit breaker is tripped.
2. Check the actual frequency of the VFD controller. To access the actual frequency, press ESC button until the Display Mode shows D001.
3. Check to see that the breaker in the service panel is not tripped.
4. Make sure the Switch Relocation Cords (SRC) are properly installed to the oven(s).
5. Check to see that the grease filters are clean & installed properly.
6. Check to see if the exhaust fan is rotating in the correct rotation. To verify fan rotation, remove the lid on the exhaust fan. Visually inspect rotation in accordance with label on fan housing.

Hood Machine Control LED Lights

1. When the Red LED is lit it indicates an MC error.
2. When the first Green LED is lit it indicates power to MC.
3. When the second Green LED is lit it indicates that the exhaust fan on.
4. When the third Green LED is lit it indicates the MC communication to the VFD.

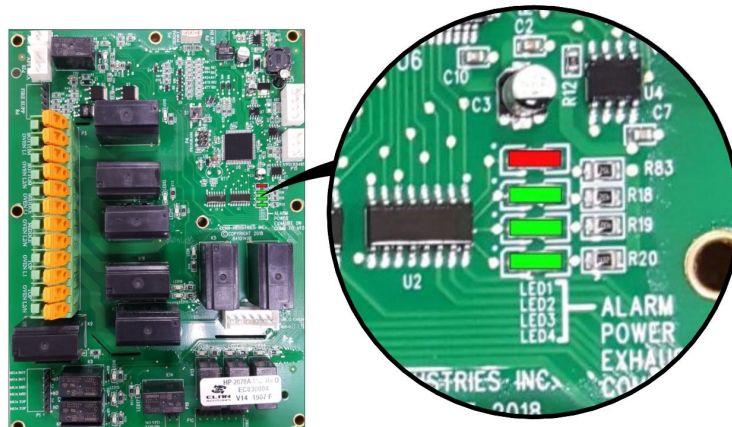

The VFD has internal diagnostics, and may show the following ERROR codes:

- F004 DC bus voltage fell below minimum value
- F005 DC bus voltage exceeded maximum value
- F007 Motor Overload
- F008 Heat sink Over Temp
- F013 Ground Fault
- F081 Comm Loss- RS-485 port stopped communicating

If any of the above error codes are displayed, then follow these steps to clear them.

1. Remove VFD control box access panel.
2. Determine cause of error code.
3. Resolve the condition that is causing error.
4. Cycle the VFD Power.

Circuit breaker must be turned off for ten (10) seconds to allow complete shut down of VFD before turning back on.

If your hood still does not function properly, XLT has qualified customer service personnel that can provide assistance on any type of XLT equipment problem you may experience. Customer Service is available 24/7/365 at 888-443-2751, or visit www.xltovens.com.

For repairs or maintenance of the fire suppression system and components, contact the local ANSUL dealer or XLT for assistance.

Large User Interface Programming Procedure



TIP

Read the entire instruction before programming.



ENTER Used to select and save parameters.

UP Increases the setting of the selected parameter.



DOWN Decrease the setting of the selected parameter.



To enter factory tech mode press both UP and DOWN button simultaneously for ten (10) seconds and the following parameters will be displayed: *Displays will auto-exit programming screens after five (5) seconds of no activity.

1. Software Version
2. Serial Number Entry
3. Elapsed Time:
 - Total Hours.
 - Hours Since Filter has been Cleaned.
4. Belt Length: 32 = 1832 36 = 2336 40 = 2440 or 3240 50 = 3250 55 = 3255 or 3855 or 4455
65 = 3265 70 = 3270 or 3870 80 = 3280 or 3880
5. Main Fan Type: Defaults to ON/OFF
6. Split Belt: Defaults to No.
7. Dual Burner: Defaults to No
8. Fuel Type:
 - Gas or Electric Options.
9. Remote Hood Switch Installed: Defaults to No.
10. Temperature Offset Adjustments:
 - Offset shown in degrees Fahrenheit.
11. High Temperature range from 590°F (310°C) to Low Temperature.
12. Low Temperature range from 300°F (150°C) to High Temperature.
13. Main Fan (Amps):
 - Press ENTER to see isolated Amp load.
14. Belt Direction: Defaults to right to left.
 - Defaults to Right to Left
 - Can be switched to left to right without physically changing the wire belt direction.
15. Main Fan Off Delay: Defaults to auto 225°F (107°C)
16. Beeper Button Test
17. Done:
 - Press ENTER to return to operating screen.

Conveyor Speed Settings



TIP

Read the entire instruction before programming.



ENTER Used to select and save parameters.

HIDDEN Behind the XLT is a hidden button. It is used with the up and down buttons to access the programming mode.

UP Increases the setting of the selected parameter.

DOWN Decrease the setting of the selected parameter.

To enter conveyor settings, press and hold three (3) buttons (HIDDEN, UP, and DOWN) for ten (10) seconds to enter. Displays will auto-exit programming screens after five (5) seconds of no activity.

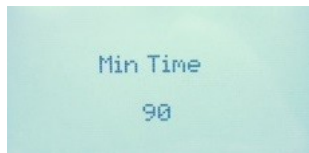
**Min Time**

Factory default is 90. To change, press ENTER. Use Up/Down arrows to change time which is shown in seconds. Press ENTER to accept and advance.

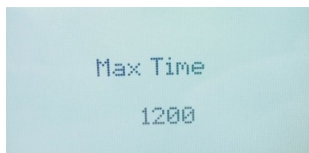
**Max Time**

Factory default is 1200. To change, press ENTER. For 1832 use 1020 and all other models will be 1200. Use Up/Down arrows to change time which is shown in seconds. Press ENTER to accept and advance.

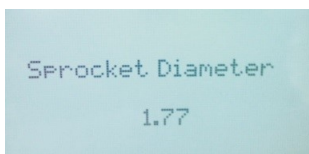
**Sprocket Diameter**

Factory default is 1.77. To change, press ENTER. Use Up/Down arrows to change diameter. Press ENTER to accept and advance.

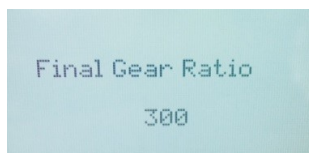
**Final Gear Ratio**

Factory default is 300. To change, press ENTER. Use Up/Down arrows to change gear ratio. Press ENTER to accept and advance.

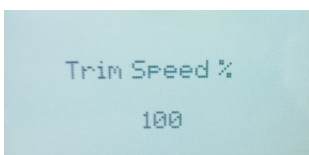
**Trim Speed**

Factory default is 101. To change, press ENTER. Use Up/Down arrows to change trim speed. Press ENTER to accept and advance.

Directional Change of the Conveyor Belt

The conveyor belt is non-directional. This means there is NO physical change of the belt when wanting to change direction. To change the direction:

Standard Belt

1. Enter Factory Tech Mode by pressing and holding the two (2) arrow buttons for ten (10) seconds.
2. Press Down arrow to cycle through screens.
3. On Belt Direction, press ENTER (direction will flash) and use Up/Down arrows to change.
4. Press ENTER to accept and advance.

Split Belt

1. Enter Factory Tech Mode by pressing and holding the two (2) arrow buttons for ten (10) seconds.
2. Press Down arrow to cycle through screens.
3. On Belt Direction, press ENTER (FRONT belt will flash) and use Up/Down arrows to change FRONT belt direction.
4. Press ENTER to accept.
5. Press ENTER (FRONT belt will flash).
6. Use the time (clock) button to toggle to BACK belt and use Up/Down arrows to change.
7. Press ENTER to accept and advance.

Invertek VFD (World) Programming Procedure





TIP

Read the entire instruction before programming.



START  When in keypad mode, used to Start a stopped drive or to reverse the direction of rotation if bi-directional keypad mode is enabled.

UP  Used to increase speed in real-time mode or to increase parameter values in parameter edit mode.

DOWN  Used to decrease speed in real-time mode or to decrease parameter values in parameter edit mode.

NAVIGATE  Used to display real-time information, to access and exit parameter edit mode and to store parameter changes.

RESET/STOP  Used to reset a tripped drive. When in Keypad mode, used to Stop a running drive.

With the Oven Control switched off and power connected to the oven, the VFD should show “Stop” on the display.



CAUTION

Do Not Exceed 65 Hz On VFD Settings.

Programming Instructions For Factory Parameters

1. Press and hold NAVIGATE > 2 seconds.
2. Press UP Arrow until (P-14) is displayed and press NAVIGATE.
3. Press UP Arrow until (201) is displayed and press NAVIGATE to save and return to parameter menu.
4. Press UP Arrow until (P-15) is displayed and press NAVIGATE.
5. Press UP Arrow until (2) is displayed and press NAVIGATE to save and return to parameter menu.
6. Press UP Arrow until (P-17) is displayed and press NAVIGATE.
7. Press UP Arrow until (24) is displayed and press NAVIGATE to save and return to parameter menu.
8. Press UP Arrow until (P-20) is displayed and press NAVIGATE.
9. Press DOWN Arrow until (0.0) is displayed and press NAVIGATE to save and return to parameter menu.
10. Press UP Arrow until (P-21) is displayed and press NAVIGATE.
11. Press UP Arrow until (60.0) is displayed and press NAVIGATE to save and return to parameter menu.
12. Press UP Arrow until (P-51) is displayed and press NAVIGATE.
13. Press UP Arrow until (1) is displayed and press NAVIGATE to save and return to parameter menu.
14. Press DOWN Arrow until (P-38) is displayed and press NAVIGATE.
15. Press UP Arrow until (1) is displayed and press NAVIGATE to save and return to parameter menu.
16. Press and hold NAVIGATE > 2 seconds to return to operating display.



TIP

Read the entire instruction before programming.

Programming Instructions For Lower Than 60 Hz

1. Press and hold NAVIGATE for > 2 seconds.
2. Press UP Arrow until (P-38) is displayed and press NAVIGATE.
3. Press DOWN Arrow until (0) is displayed and press NAVIGATE to save and return to parameter menu.
4. Press DOWN Arrow until (P-21) is displayed and press NAVIGATE.
5. Press DOWN Arrow until desired Hz is displayed and press NAVIGATE to save and return to parameter menu.
6. Press UP Arrow until (P-38) is displayed and press NAVIGATE.
7. Press UP Arrow until (1) is displayed and press NAVIGATE to save and return to parameter menu.
8. Press and hold NAVIGATE > 2 seconds to return to operating display.

Programming Instructions For Up To 65 Hz Max

1. Press and hold NAVIGATE for > 2 seconds.
2. Press UP Arrow until (P-38) is displayed and press NAVIGATE.
3. Press DOWN Arrow until (0) is displayed and press NAVIGATE to save and return to parameter menu.
4. Press DOWN Arrow until (P-1) is displayed and press NAVIGATE.
5. Press UP Arrow until (65.0) is displayed and press NAVIGATE to save and return to parameter menu.
6. Press UP Arrow until (P-21) is displayed and press NAVIGATE.
7. Press UP Arrow until desired Hz is displayed and press NAVIGATE to save and return to parameter menu.
8. Press UP Arrow until (P-38) is displayed and press NAVIGATE.
9. Press UP Arrow until (1) is displayed and press NAVIGATE to save and return to parameter menu.
10. Press and hold NAVIGATE for > 2 seconds to return to operating display.

On-Off Valve Adjustment Procedure

Gas Oven Fuel Pressure Requirements														
Oven Models	Inlet Pressure Range								Manifold Pressure					
	Standard, World, Australia and New Zealand						Korea		Natural Gas			LP Gas		
	Natural Gas			LP Gas			Natural Gas	LP Gas	Natural Gas		LP Gas			
	W/C	mbar	kPa	W/C	mbar	kPa	kPa	kPa	W/C	mbar	kPa	W/C	mbar	kPa
All	6-14	15-35	1.50-3.50	11-14	27.5-35	2.75-3.50	1.50-2.50	2.30-3.30	3.5	8.75	0.875	10	25	2.5

Check Incoming Pressure:

- Loosen screw one (1) full turn counter clockwise (Figure 1).
- Connect Manometer to this test port.
- Turn the LUI to on position and wait for burner to light (up to 30 seconds).
- Document incoming pressure on startup checklist.(If new installation)

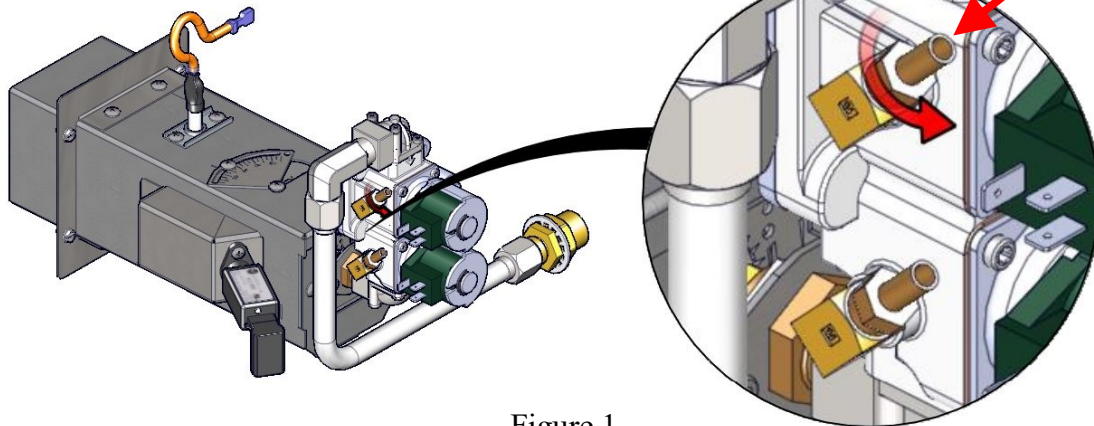

Figure 1

- Disconnect Manometer.
- Tighten screw clockwise until snug (Figure 2).

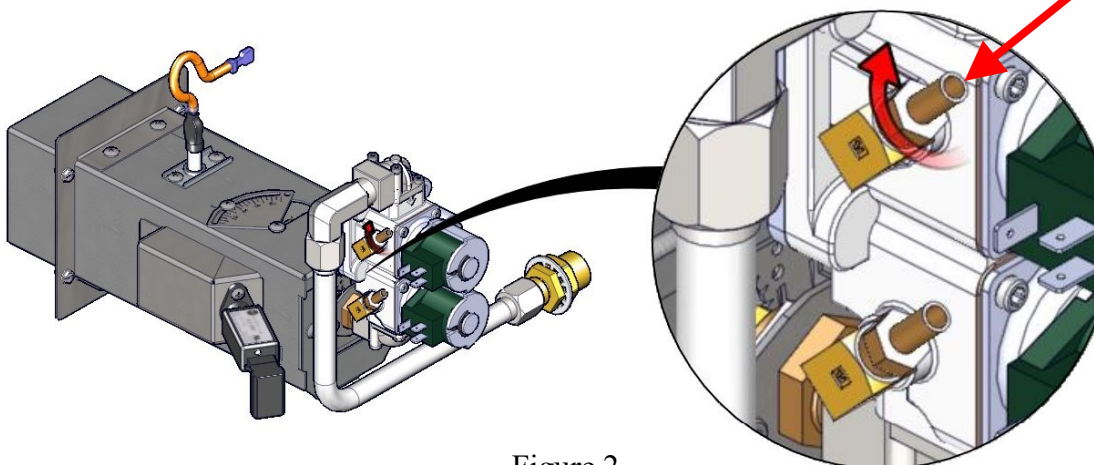

Figure 2



NOTE

If your oven rises above set point, contact XLT for instructions to make bypass orifice adjustments.

On-Off Valve Adjustment Procedure

Check High Bias Pressure:

- Loosen adjustment screw one (1) full turn counter-clockwise (Figure 3).
- Connect Manometer to this test port.
- Turn the LUI to on position and wait for burner to light (up to 30 seconds).

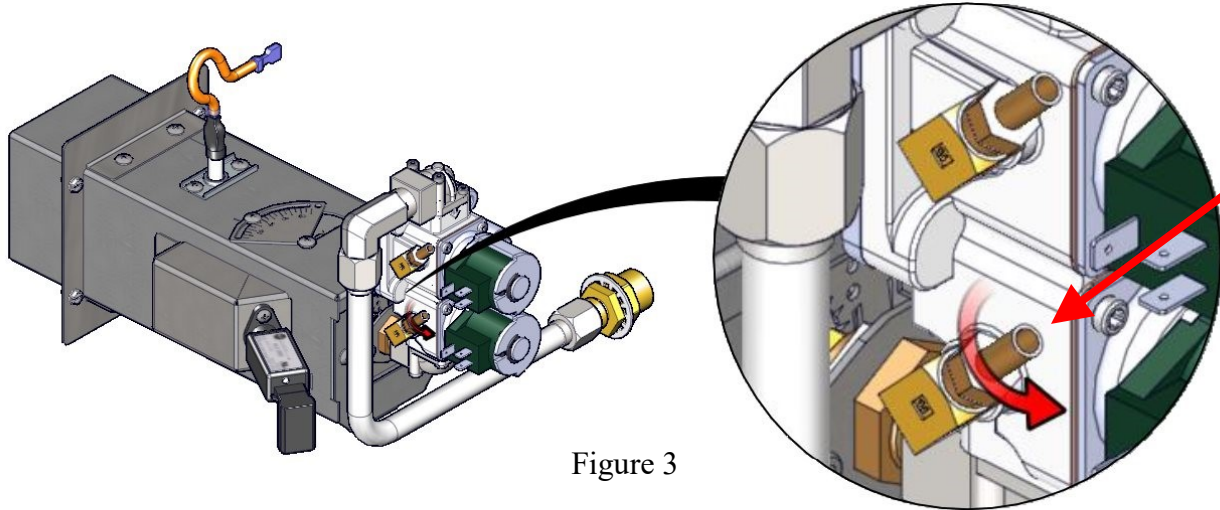

Figure 3

- Remove Seal Screw.
- Turn the High Flame Bias Screw located behind the Seal Screw (Figure 4) until desired setting is achieved. Use chart below for correct valve settings.
- Reinstall Seal Screw.
- Disconnect Manometer.

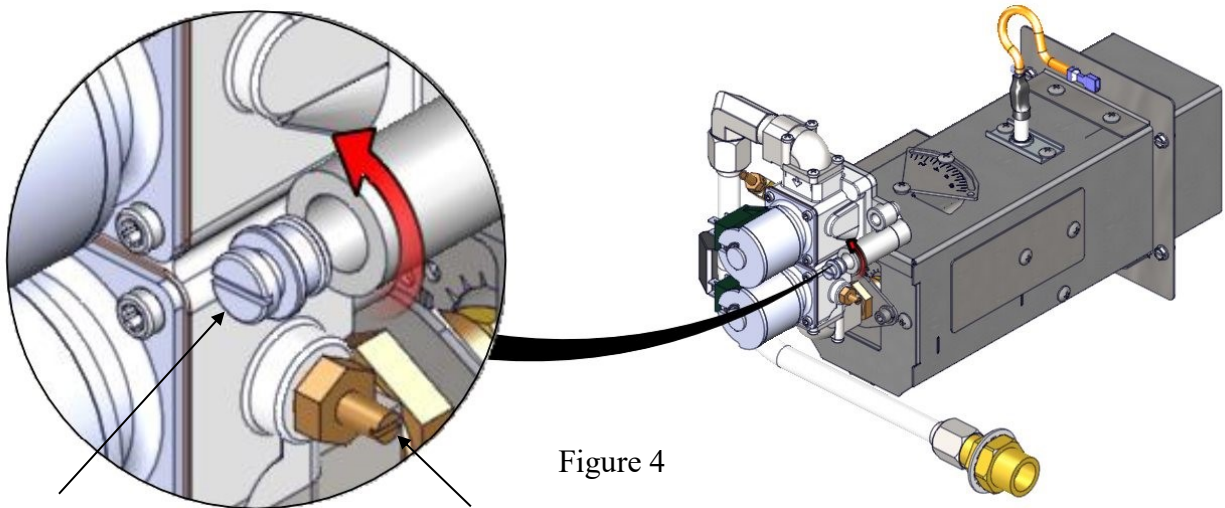

Figure 4

Seal Screw

Adjustable Bypass Orifice

Multi-Valve Adjustment Settings						
All Oven Models	Natural Gas			LP Gas		
	W/C	mbar	kPa	W/C	mbar	kPa
High Flame Bias	3.5	8.75	0.875	10	25	2.5

Air Shutter Settings - Original

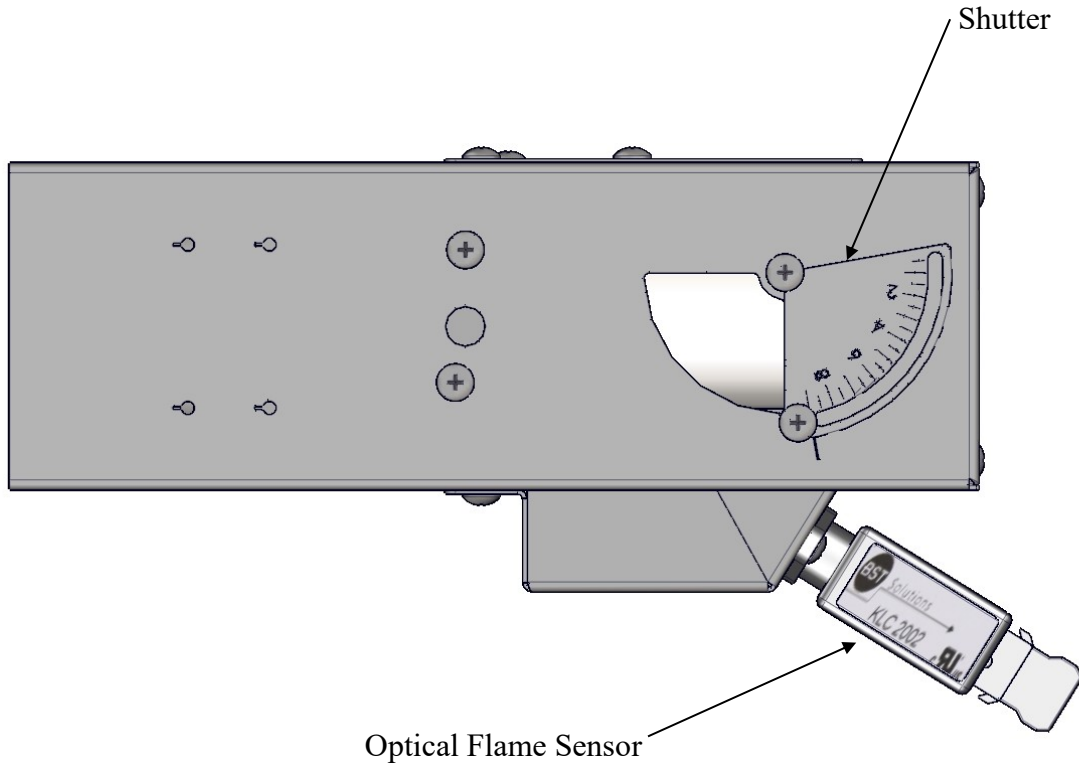

Recommended Burner Shutter Settings		
All Oven Models	Natural Gas	LP Gas
Shutter	9.0	9.0



New Installation– The shutter has been set at the factory. This should not need adjusted. If found loose call technical support for settings.

Allen Bradley Power Flex 4M Restoring XLT Hood Defaults



TIP

Read the entire instruction before programming.

To reset VFD settings change P112 to one (1) . The VFD will reset to factory default settings. To cycle power, turn circuit breaker off and on and the HMC will load the factory parameters into the VFD.

P105=65	Maximum Frequency
P106=2	Start Source
P108=4	Speed Reference
P110=2	Decel Time
A451=9	Auto Reset Tries
A452=60	Auto Reset Delay
T201=2	Terminal Block Group (I/O) Terminal 5
T202=6	Terminal Block Group (I/O) Terminal 6
A404=60	Jog Frequency

Test run the motor by turning on one of the oven/hood buttons located on the HUI.



ENTER Used to select and save parameters.



SELECT Advances one step in programming menu. Selects a digit when viewing parameter values.



ESCAPE Used to return to previous menu.

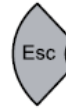

UP Increases the setting of the selected parameter.



DOWN Decrease the setting of the selected parameter.



Complete VFD manual available at www.xltovens.com.

The VFD controller is adjusted at the factory to the values displayed in the chart below.

VFD Controller Settings							
Ovens On			1832, 2336, & 2440	3240, 3250DS, 3255, 3265DS, 3270, 3280, & 3280DS	3855, 3870, & 3880DS	4455	
Top	Middle	Bottom					
Single	X			20 Hz	25 Hz	30 Hz	30 Hz
	X			20 Hz	25 Hz	30 Hz	30 Hz
Double			X	20 Hz	30 Hz	35 Hz	45 Hz
	X		X	20 Hz	30 Hz	35 Hz	45 Hz
Triple	X			20 Hz	25 Hz	30 Hz	30 Hz
		X		20 Hz	30 Hz	35 Hz	45 Hz
			X	30 Hz	35 Hz	40 Hz	50 Hz
	X	X		20 Hz	30 Hz	35 Hz	45 Hz
	X		X	30 Hz	35 Hz	40 Hz	50 Hz
		X	X	30 Hz	35 Hz	40 Hz	50 Hz
	X	X	X	30 Hz	35 Hz	40 Hz	50 Hz
Fire Suppression			60 Hz DO NOT CHANGE				

If you require either more or less air flow, follow these steps: (Reference Hood User Interface image on next page)

1. Press & hold the LIGHTS and XLT LOGO buttons to enter into factory tech mode.
2. Use the Up/Down arrows to reach manual air balance.
3. Press and hold ENTER button for three (3) seconds. Entire row will flash.
4. Scroll to desired oven setting. Press ENTER.
5. +/- should flash and it allows +/- change up to 10 Hz.
6. Press ENTER to save changes.
7. Press ON to test air balance.

How To Order Parts

Have all information ready when calling XLT. Below is a list of information that is required for all orders. At the bottom of the Bill of Materials (BOM) on the following parts overview pages are additional requirements needed depending on your parts order.

Oven/Hood information required:

- Model #
- Serial #
- Manufacture Date
- Phone #
- Contact name
- Bill to
- Ship to
- Credit card information



NOTE

CALL FOR PRICING.



NOTE

All parts images are for reference only. Some design characteristics differ by model. **All prices are subject to change, contact XLT for current prices.**

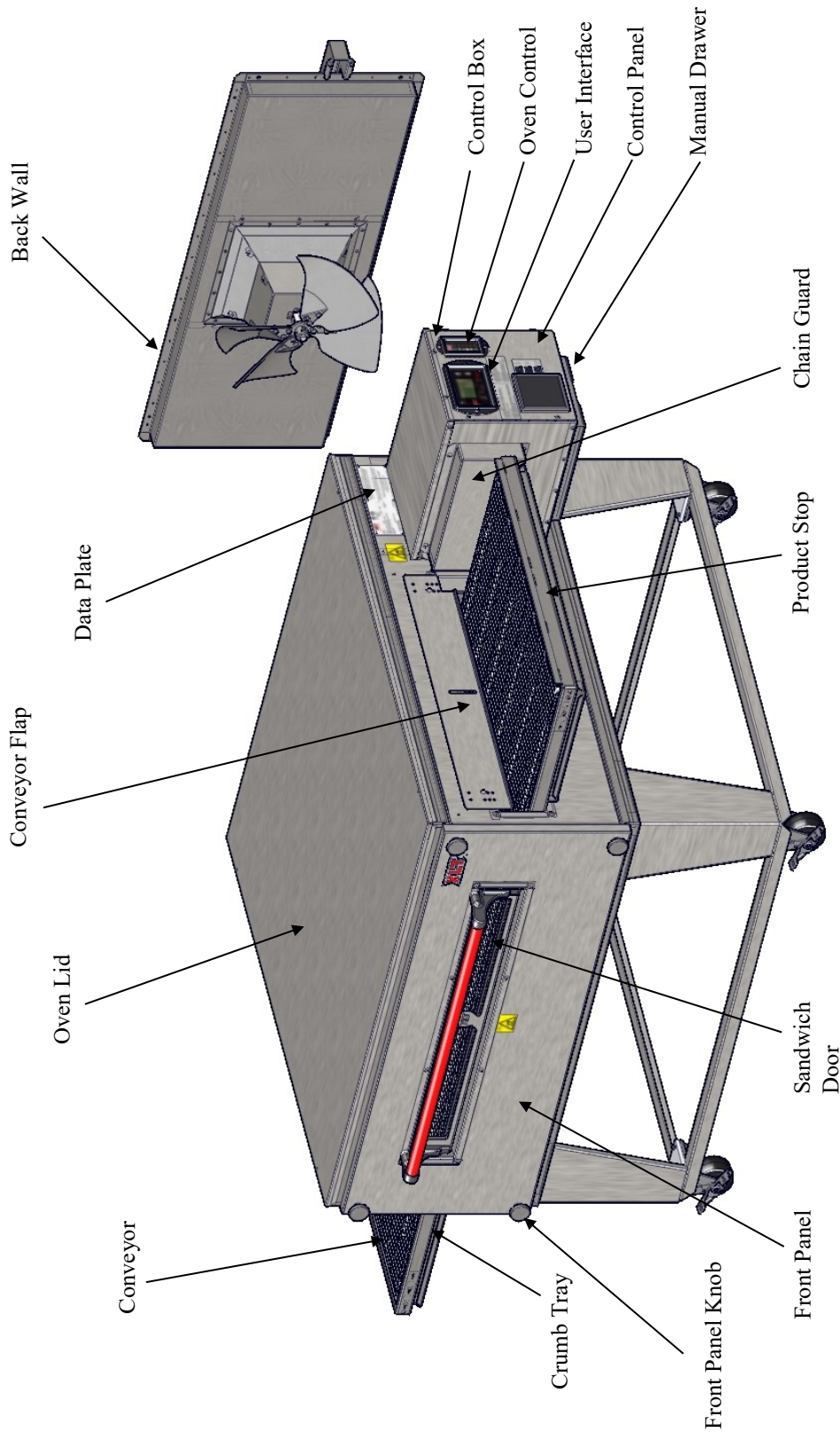

Control box package may vary based on date of manufacture. Control package shown above for overall oven reference only.



Individuals with pacemakers or internal medical devices should not handle strong rare-earth magnets. These magnets are found in the sandwich door assembly.

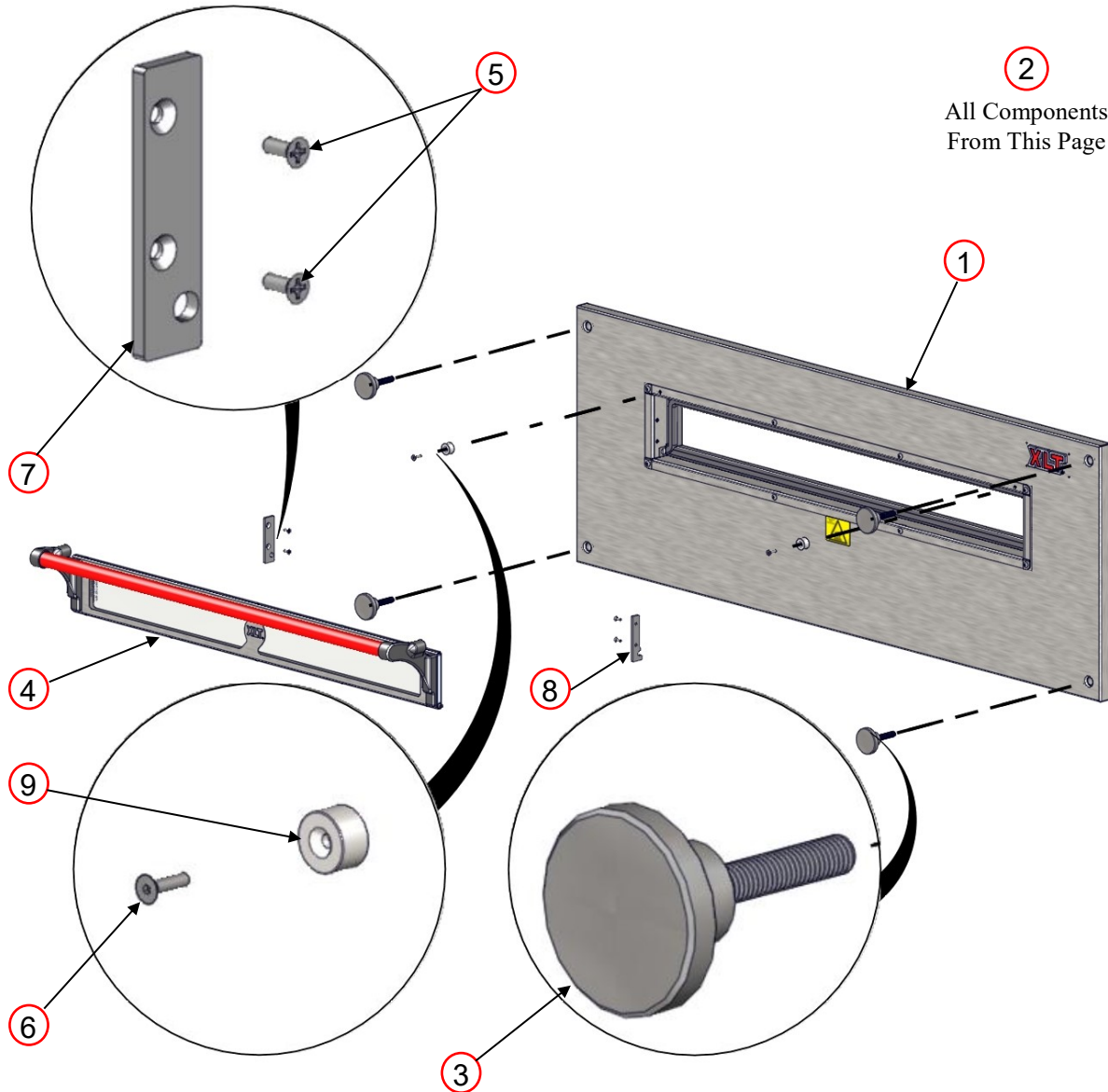

All Components
From This Page

FRONT PANEL		
ITEM	PART NUMBER	DESCRIPTION
1	XA 6400	Front Panel
2	XA 6500	Front Panel Assembly
3	XA 6505	Front Panel Knob
4	XA 6600	Sandwich Door
5	XF 126-2	Screw 10-24 x 1/2
6	XF 242	Screw 10-24 x 1/2
7	XM 6703	Door Retainer Left
8	XM 6704	Door Retainer Right
9	XP 6519	Window Steel Slug

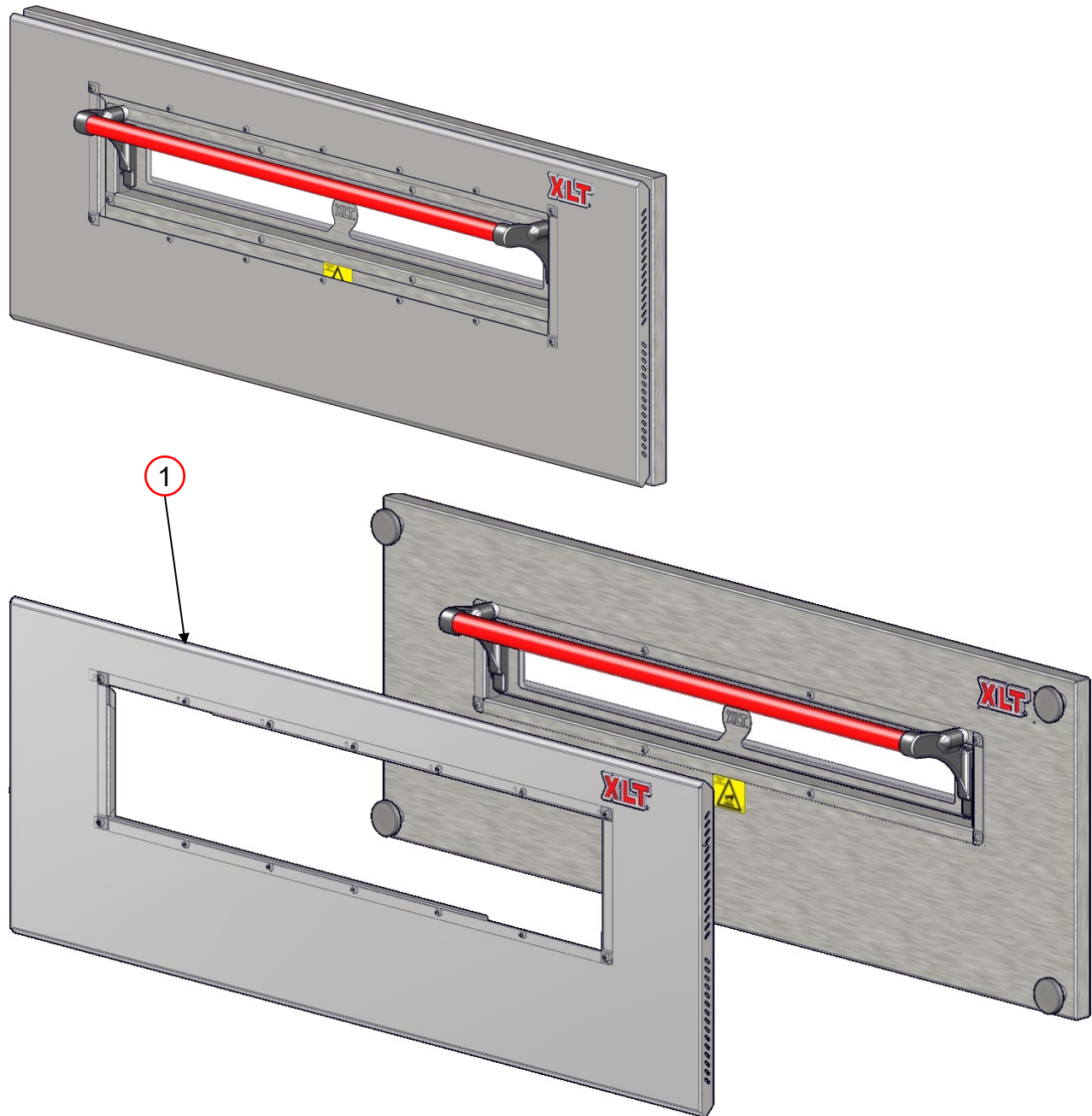

EXTENDED FRONT PANEL		
ITEM	PART NUMBER	DESCRIPTION
1	XA 6700	Extended Front Panel

Front Panel information required:

- Size of Oven
- Short or Long Sandwich Door, or No Door
- Stainless, Wood, or Painted Handle

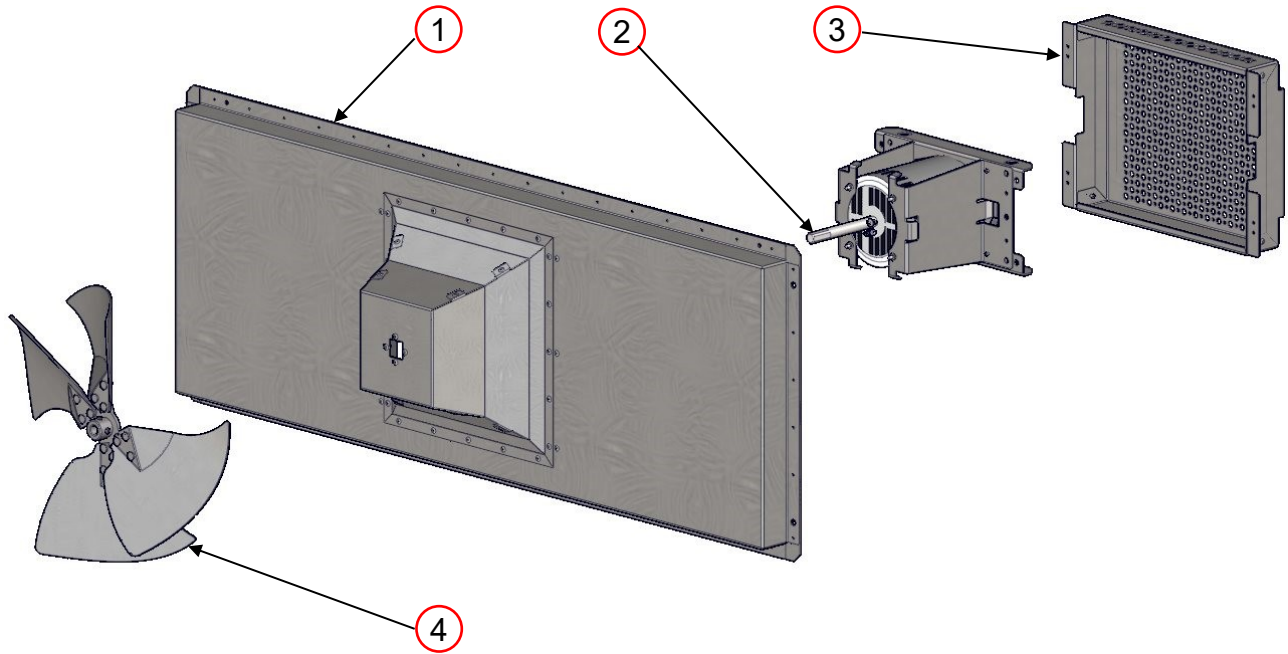

BACK WALL - STANDARD		
ITEM	PART NUMBER	DESCRIPTION
1	XA 5001	Back Wall Assembly
2	XA 5009-75	Oven Fan Motor M1
3	XA 5121	Motor Cover Assembly GAS
4	XA 5300	Fan Blade

BACK WALL - WORLD		
ITEM	PART NUMBER	DESCRIPTION
1	XA 5001	Back Wall Assembly
2	XA 5009-75-3PH	Oven Fan Motor M1
3	XA 5121	Motor Cover Assembly GAS
4	XA 5300	Fan Blade

Back Wall information required:

- Size of Oven
- Voltage

Installed Fan Height

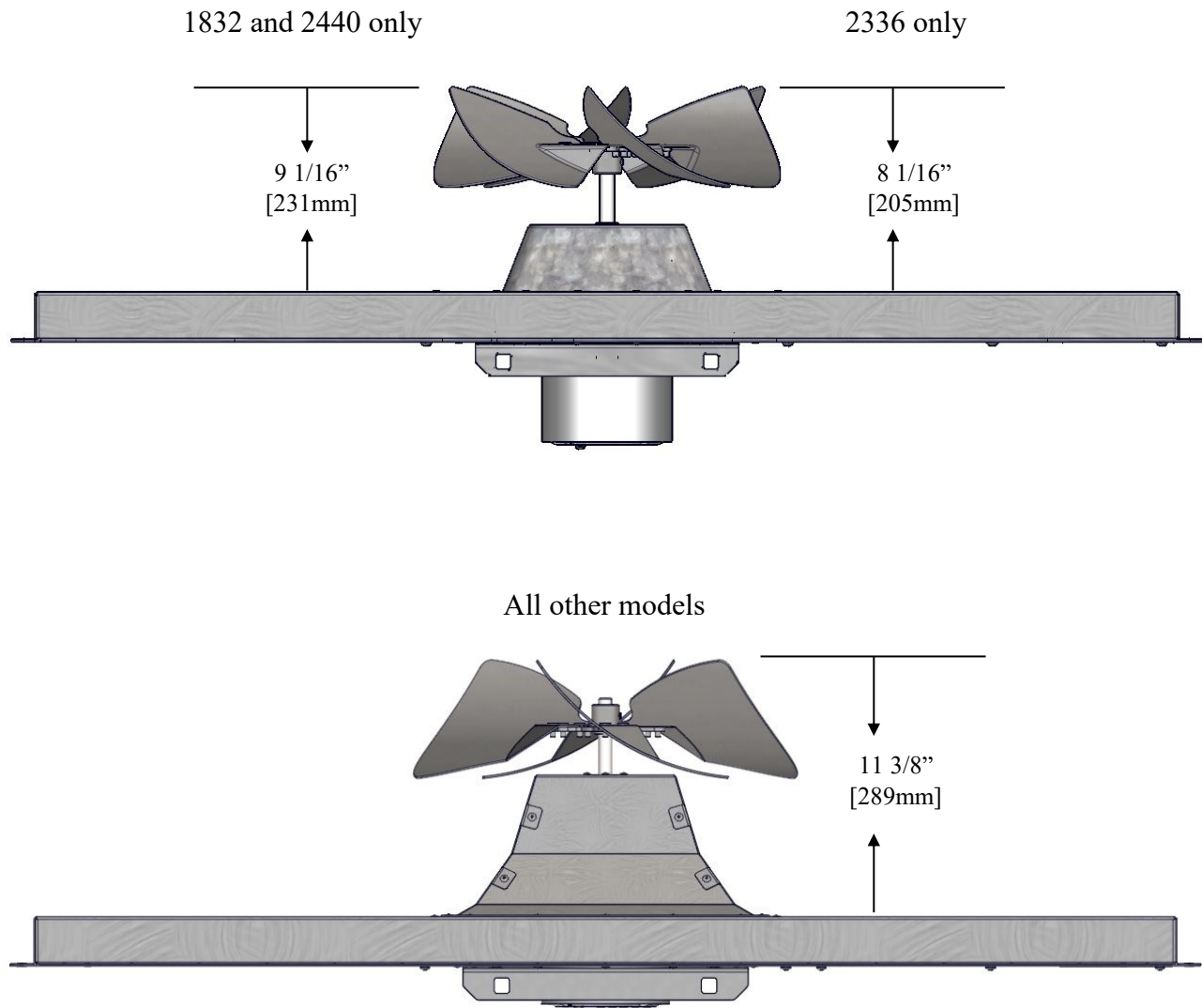

Standard Belt

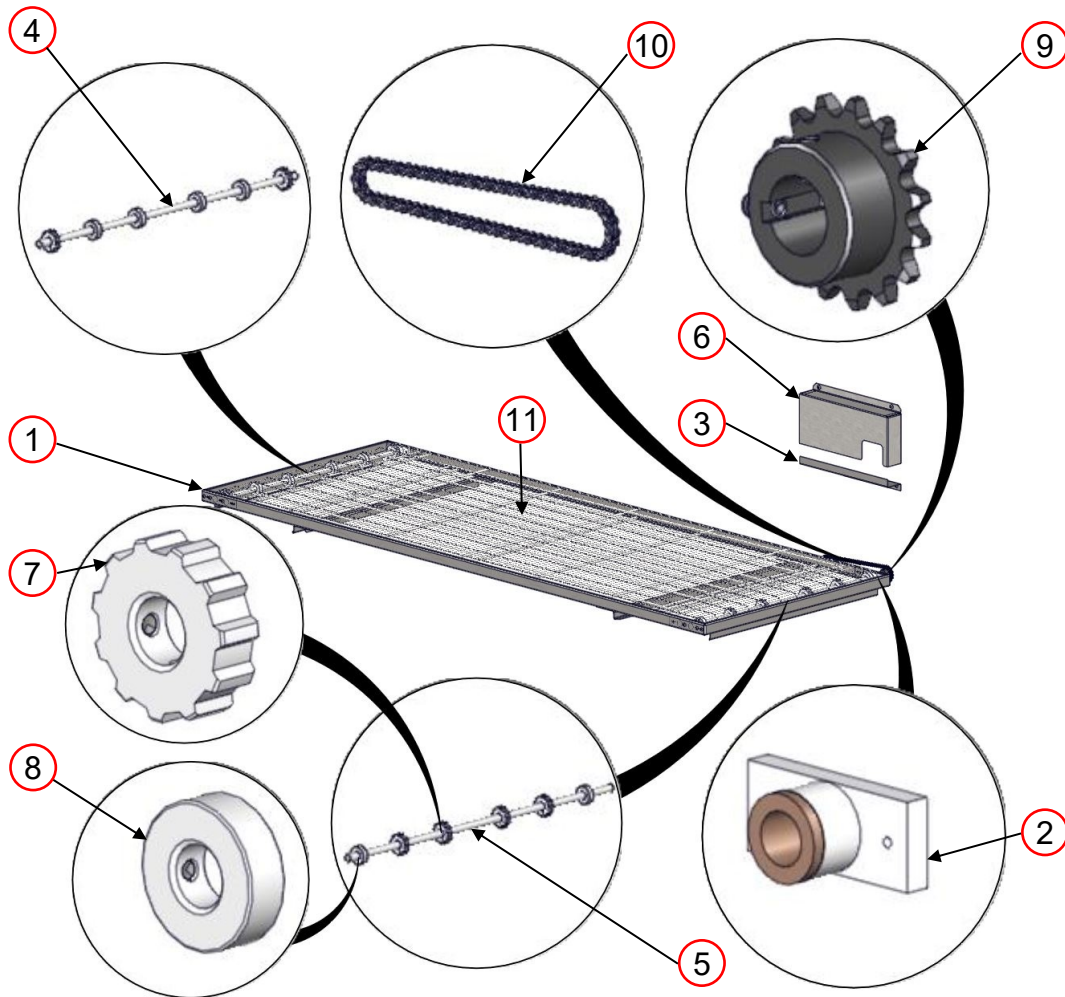

CONVEYOR		
ITEM	PART NUMBER	DESCRIPTION
1	XA 7000	Conveyor Assembly Complete
2	XA 7200	Conveyor Bearing Assembly
3	XM 4006	Chain Guard Lower
4	XM 7301	Conveyor Shaft Idle
5	XM 7302	Conveyor Shaft Drive
6	XM 9508	Chain Guard
7	XP 7403	Conveyor Roll Notched
8	XP 7404	Conveyor Roll Plain
9	XP 9503	Conveyor Sprocket Driven 15
10	XP 9505	Roller Chain
11	XP 9506	Conveyor Belt

Conveyor information required:

- Oven Size
- Right or Left Hand Controls

Split Belt

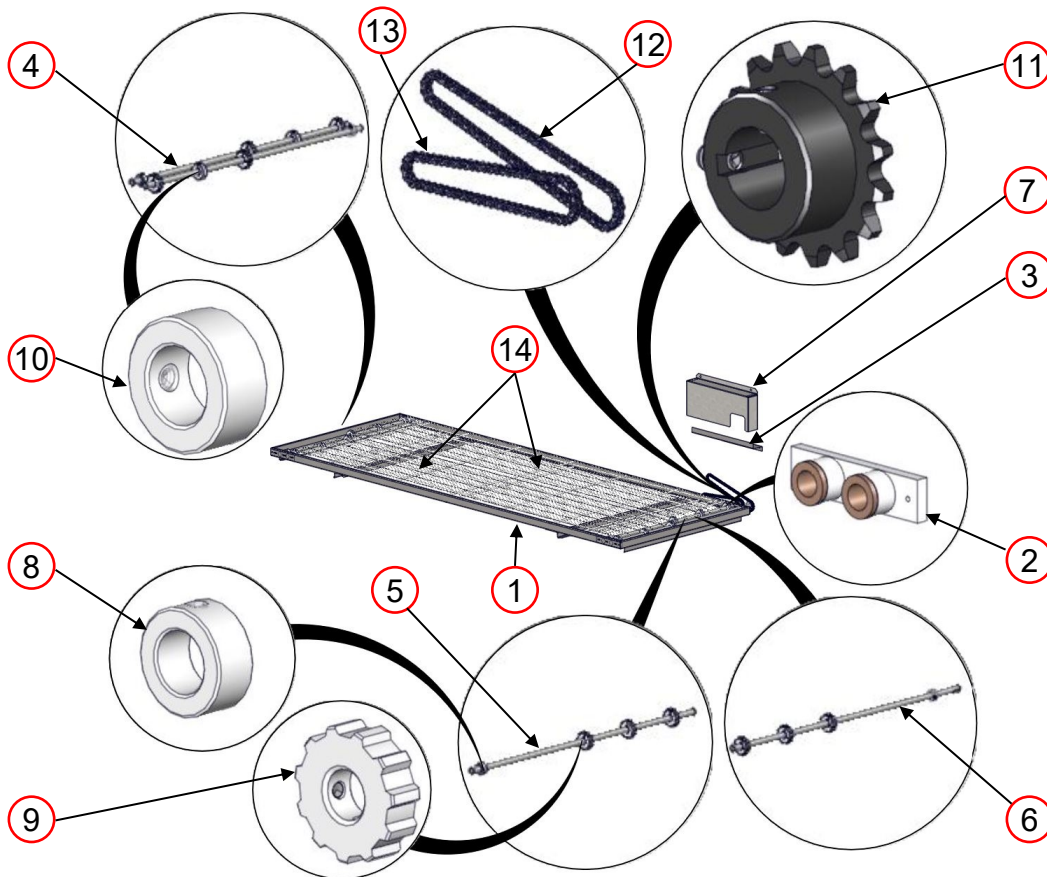

CONVEYOR		
ITEM	PART NUMBER	DESCRIPTION
1	XA 7000	Conveyor Assembly Complete
2	XA 7200	Conveyor Bearing Assembly
3	XM 4006	Chain Guard Lower
4	XM 7303	Conveyor Shaft Idle
5	XM 7304	Conveyor Shaft Drive SB INSIDE
6	XM 7305	Conveyor Shaft Drive SB OUTSIDE
7	XM 9508	Chain Guard
8	XP 7206	Shaft Collar
9	XP 7403	Conveyor Roll Notched
10	XP 7404	Conveyor Roll Plain
11	XP 9503	Conveyor Sprocket Driven 15
12	XP 9505	Roller Chain
13	XP 9505-SB	Roller Chain Split Belt
14	XP 9506	Conveyor Belt

Conveyor information required:

- Oven Size
- Right or Left Hand Controls

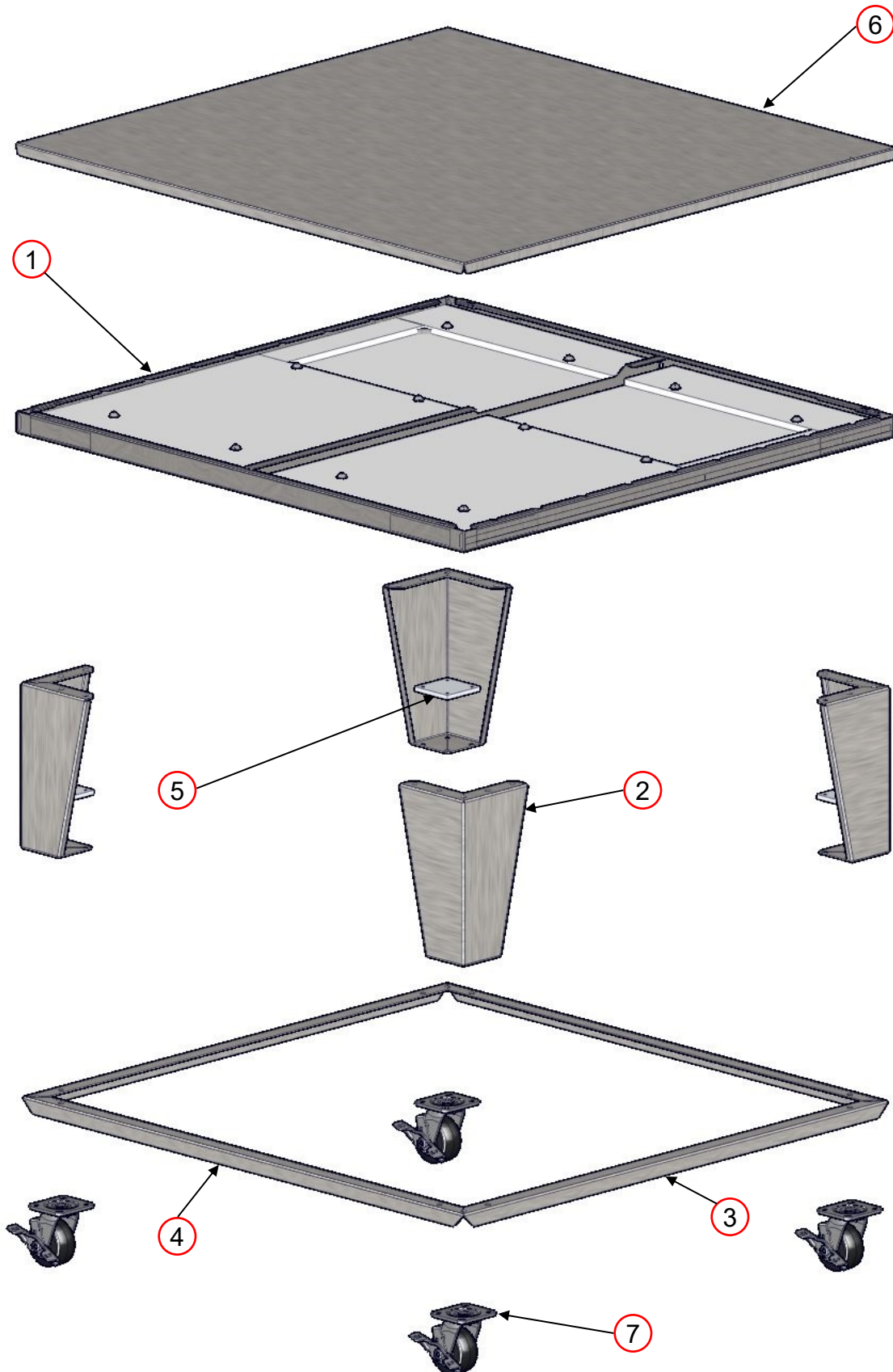

BASE		
ITEM	PART NUMBER	DESCRIPTION
1	XA 1001	Base Assembly Bare
2	XM 1003-15	Base Leg
3	XM 1006	Side Leg Angle
4	XM 1007	Front/Back Leg Angle
5	XM 1008	Bolster Plate
6	XM 1010	Oven Lid
7	XP 1004	Caster

Base information required:

- Size of Oven
- Single, Double, Triple, or Quad Stack

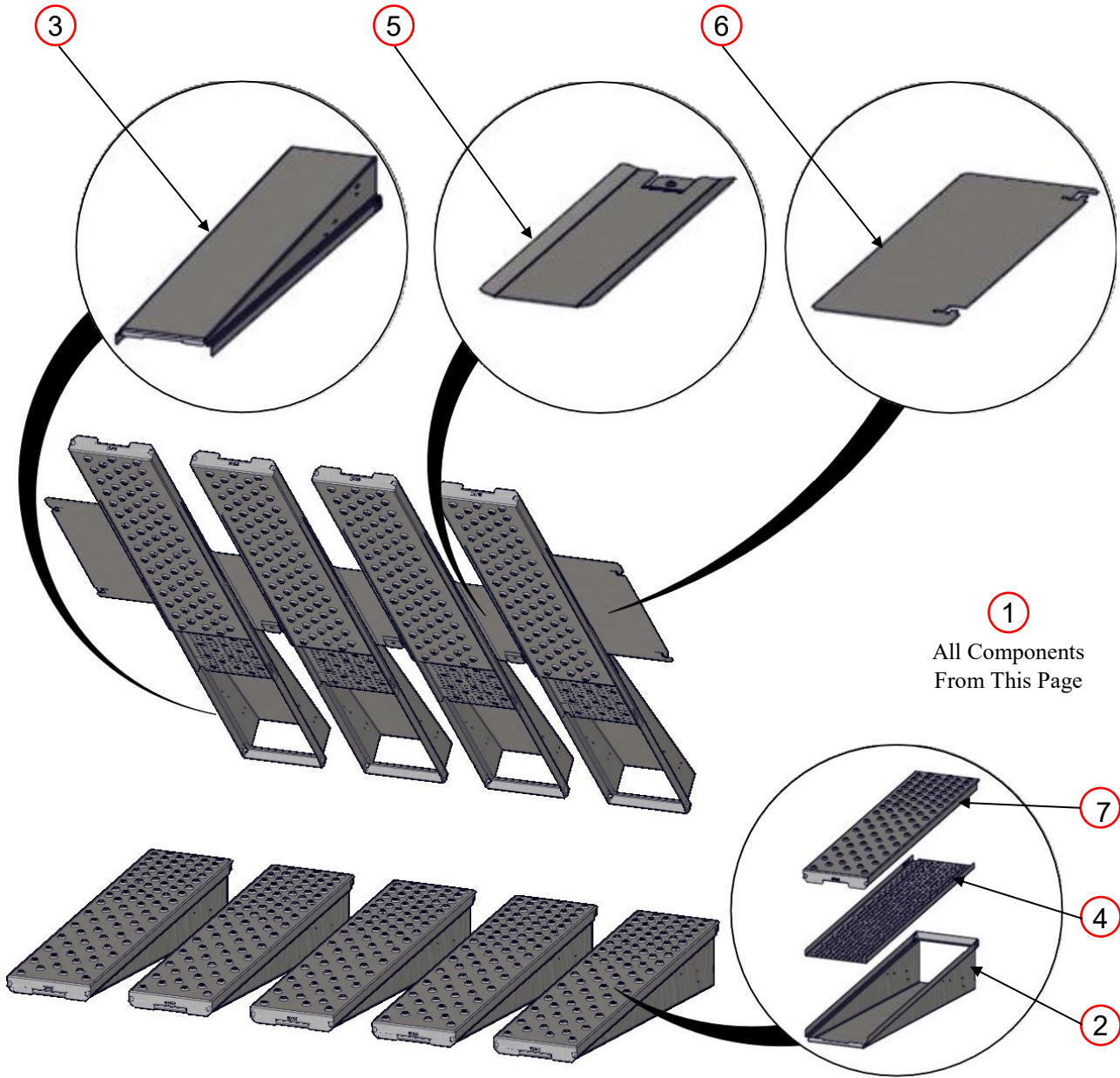

FINGERS		
ITEM	PART NUMBER	DESCRIPTION
1	XA 8Hxxxx	Finger Group Assembly
2	XA 8001-B	Finger Body Bottom
3	XA 8001-T	Finger Body Top
4	XM 8004	Finger Inner Plate Perforated
5	XM 8024	Return Air Plate
6	XM 8025	Endloss Plate
7	XM 8xxx	Finger Outer Plate

Finger information required:

- Size of Oven
- Customer name
- Part number on front of finger outer

Standard Belt

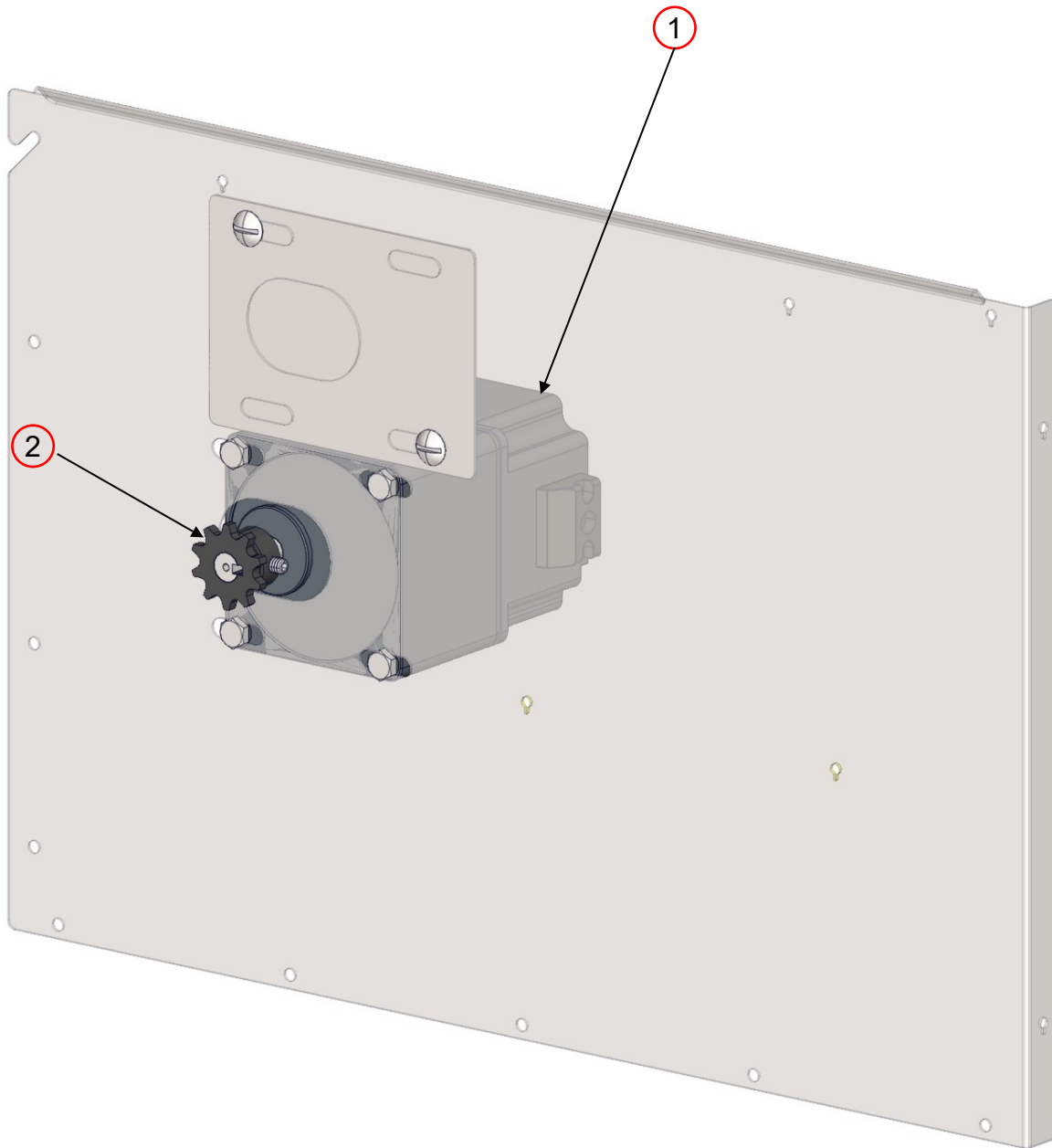

CONTROL BOX FRONT - Standard Belt		
ITEM	PART NUMBER	DESCRIPTION
1	XA 4117A-ZD ST	Conveyor Motor Assembly ZD Standard
2	XP 4155A-12mm	Sprocket Conveyor Drive 10T

Control Box Front information required:

- Size of Oven

Split Belt

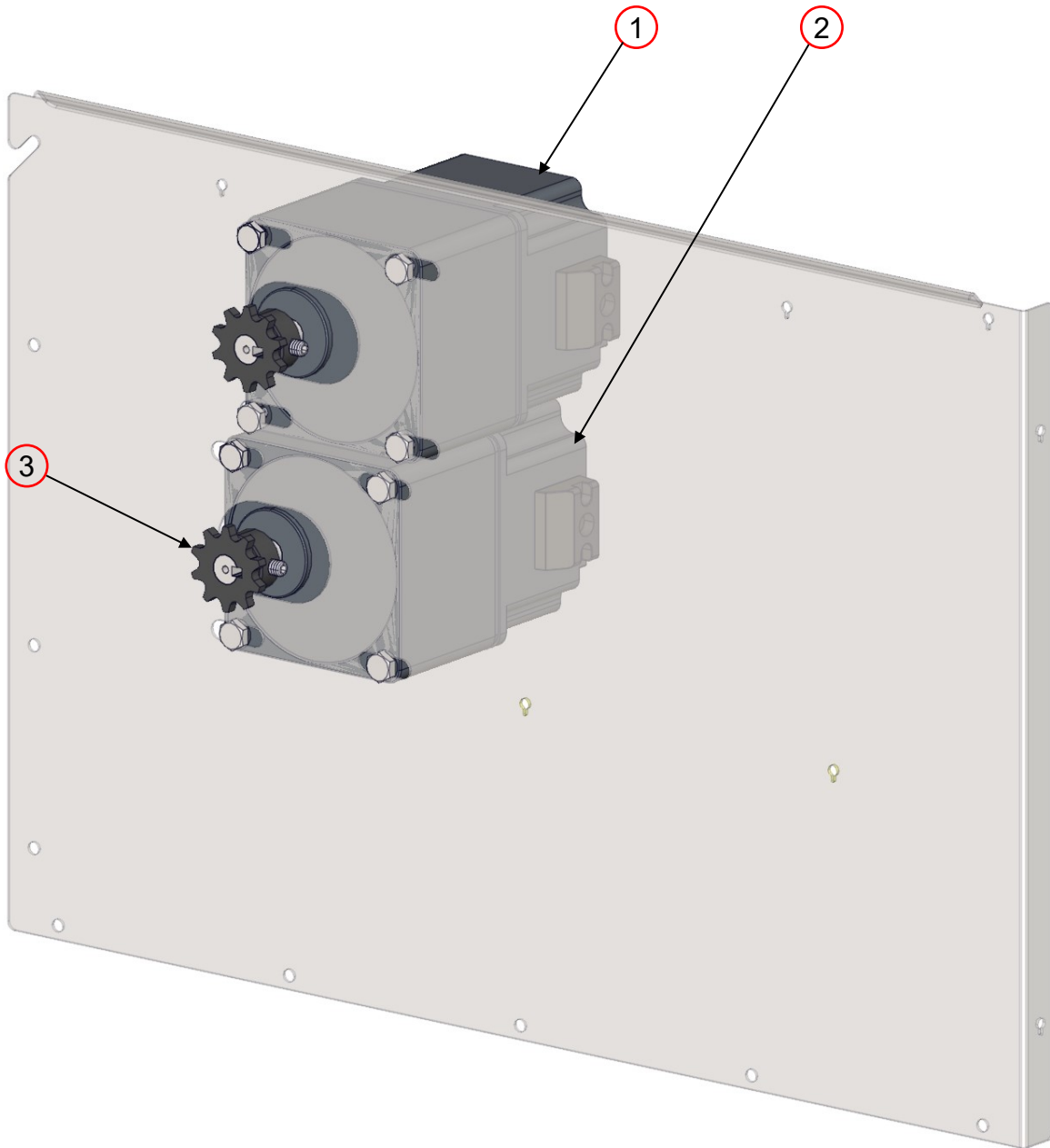

CONTROL BOX FRONT - Split Belt		
ITEM	PART NUMBER	DESCRIPTION
1	XA 4117A-ZD SB	Conveyor Motor Assembly ZD Split
2	XA 4117A-ZD ST	Conveyor Motor Assembly ZD Standard
3	XP 4155A-12mm	Sprocket Conveyor Drive 10T

Control Box Front information required:

- Size of Oven

FS/SI Assembly

①

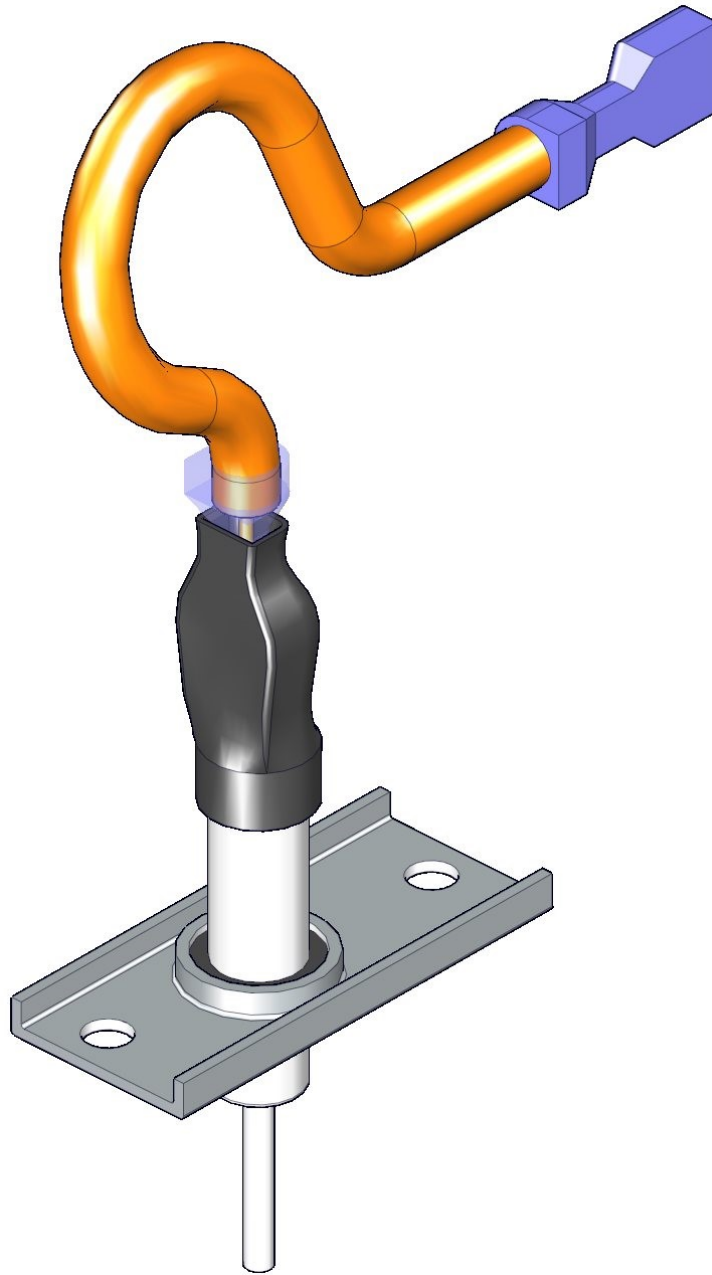

BURNER		
ITEM	PART NUMBER	DESCRIPTION
1	XA 4203-DI-SQ	Spark Rod SR

Gas Conversion Kits

①

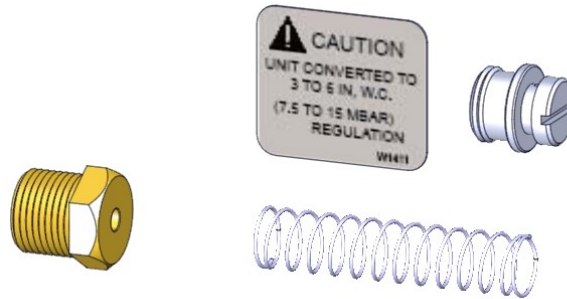

NATURAL GAS VALVE		
ITEM	PART NUMBER	DESCRIPTION
1	SP 9910-QF-NAT	Natural Gas Conversion Kit

Gas Valve information required:

- Size of Oven

①

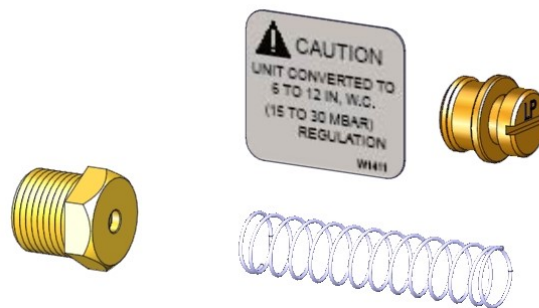

PROPANE GAS VALVE		
ITEM	PART NUMBER	DESCRIPTION
1	SP 9910-QF-LPG	LPG Conversion Kit

Gas Valve information required:

- Size of Oven

Integrated Control Package Operating Position (shown with lid removed)

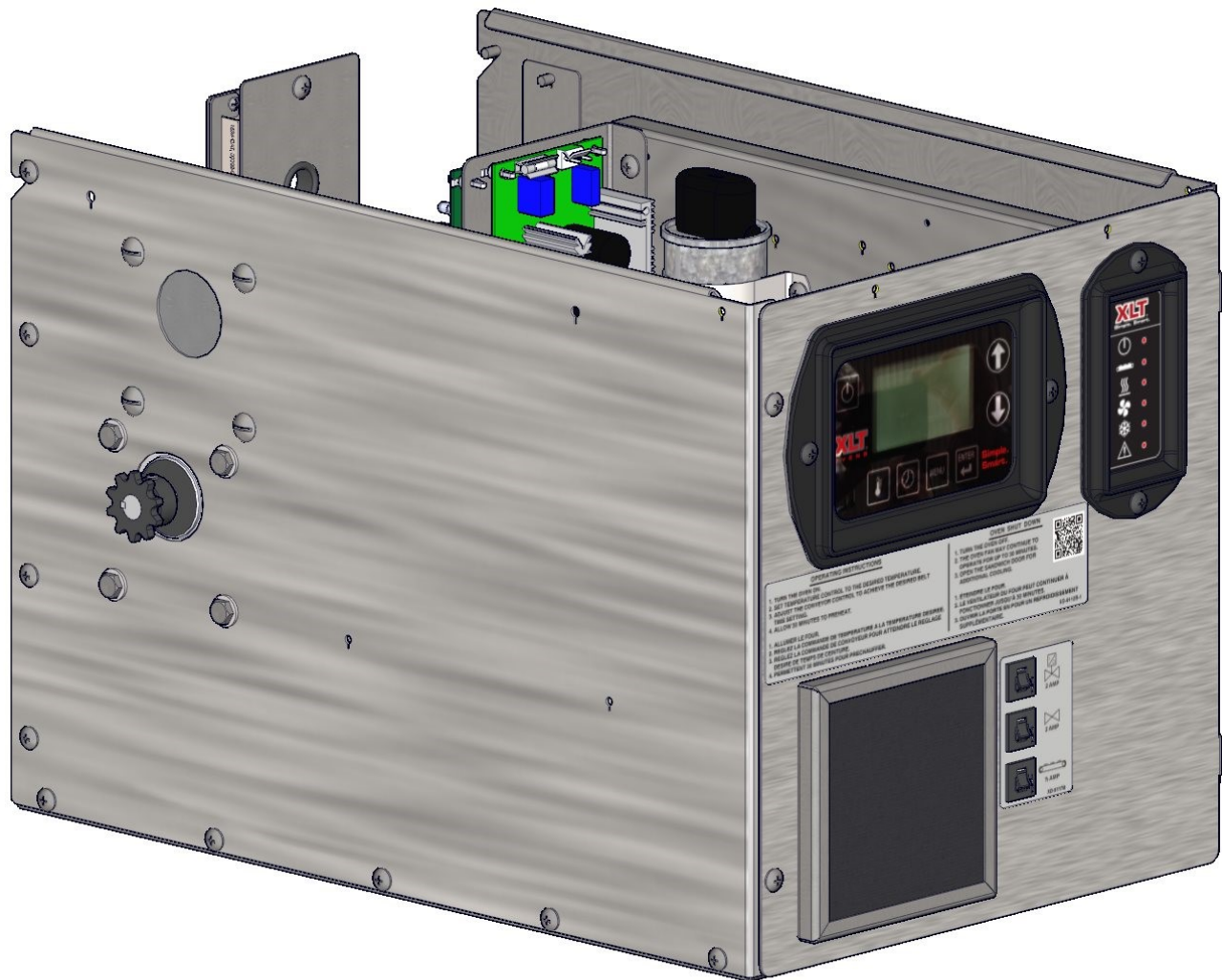

Integrated Control Package Service Position

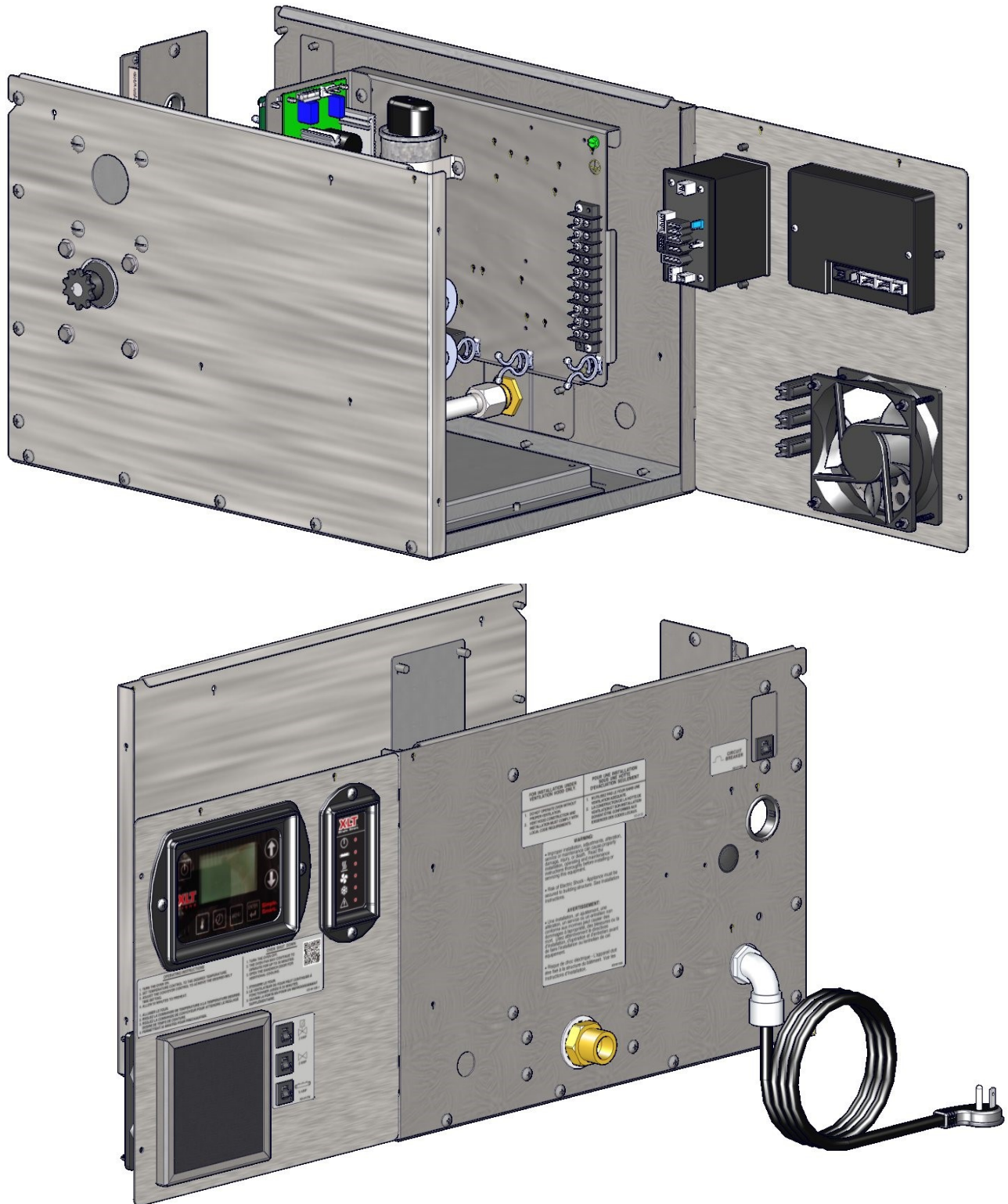

Integrated Control Package

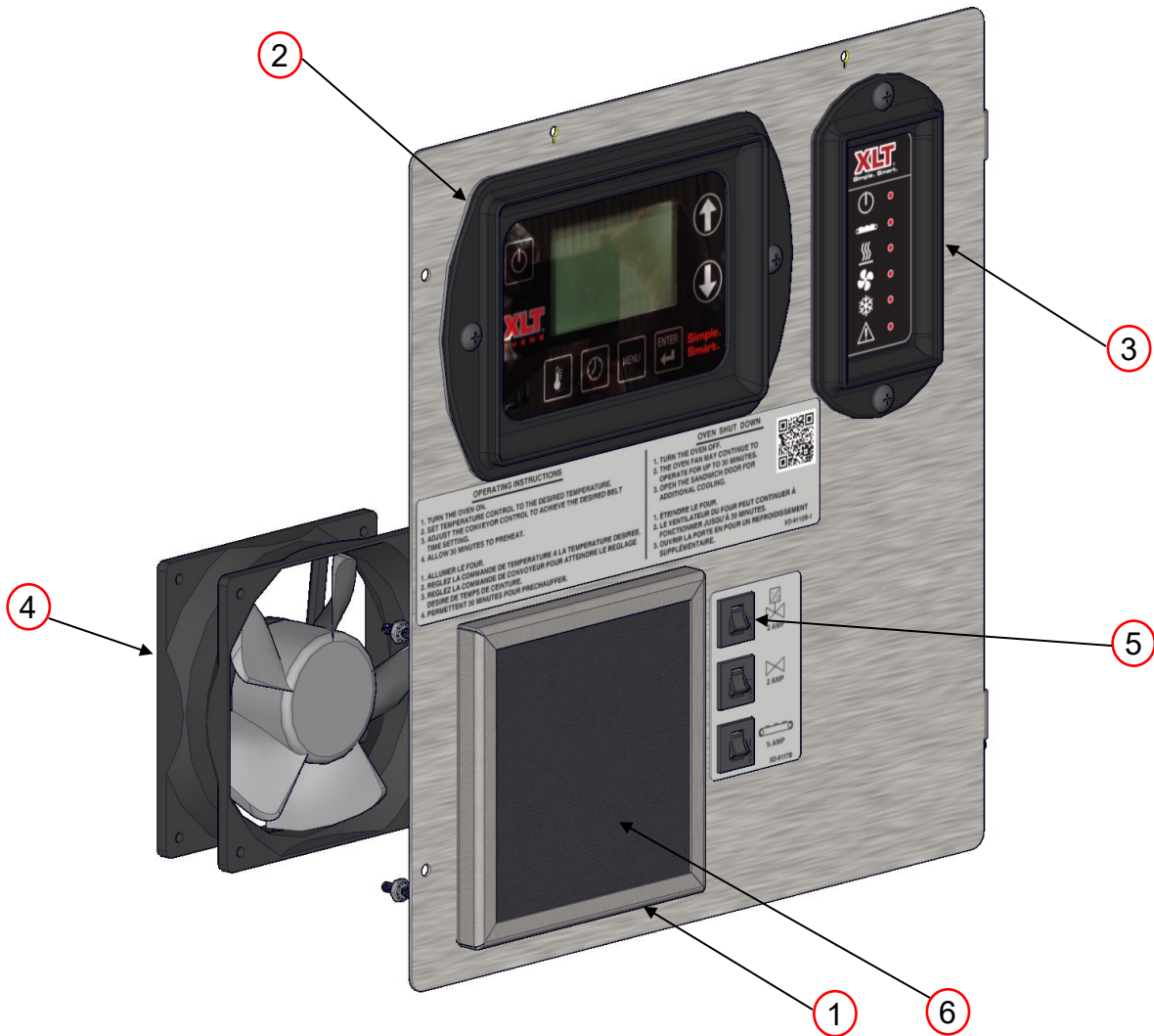

CONTROL PANEL		
ITEM	PART NUMBER	DESCRIPTION
1	SP 4520-GA	Fan Guard / Filter Repl Kit GAS
2	XP 4170-LUI	Large User Interface LUI
3	XP 4175-MC	Oven Machine Control OMC
4	XP 4501-GA	FPPG Fan Standard M3
5	XP 4515-CB	Circuit Breaker CB
6	XP 4520-GA	Fan Filter

Control Panel information required:

- Size of Oven
- Voltage
- Circuit Breaker amp rating
- Conveyor Belt direction

Integrated Control Package

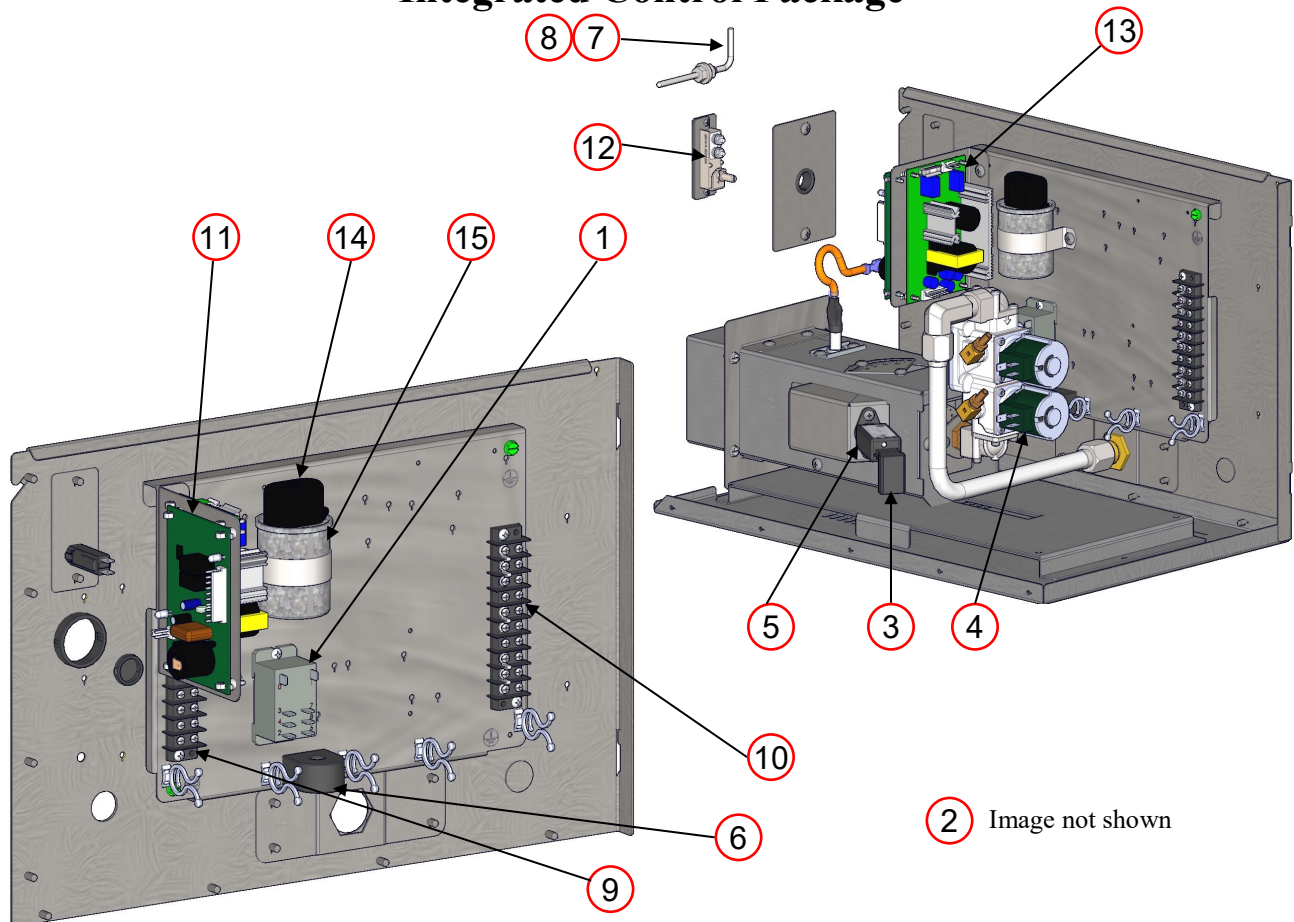

CONTROL BOX INTERIOR		
ITEM	PART NUMBER	DESCRIPTION
1	HP 2067-24VDC	Oven Fan Motor Relay R1
2	XH-4117A-Elan	Conveyor Motor Jumper Harness
3	XH 4211-DC	UV Flame Sensor Wire Plug
4	XP 4207-DI-N/P	Gas Valve V1-V2
5	XP 4210-UV-DC	Flame Sensor FS
6	XP 4310	Current Sensor CS
7	XP 4509-90	Thermocouple Type K 39 TC
8	XP 4510-90	Thermocouple Type K 90 TC
9	XP 4701-04	Terminal Strip 4 Place TS
10	XP 4701-10	Terminal Strip 10 Place TS
11	XP 4705-DI-24	Ignition Control IC
12	XP 4713A	High Temp Limit Switch S3
13	RP 4717	Power Supply PS
14	XP 5012	Capacitor Boot
15	XP 5014-30	Capacitor Baldor 3/4 HP 30uF CAP

Control Box Interior information required:

- Size of Oven
- Voltage

Integrated Control Package

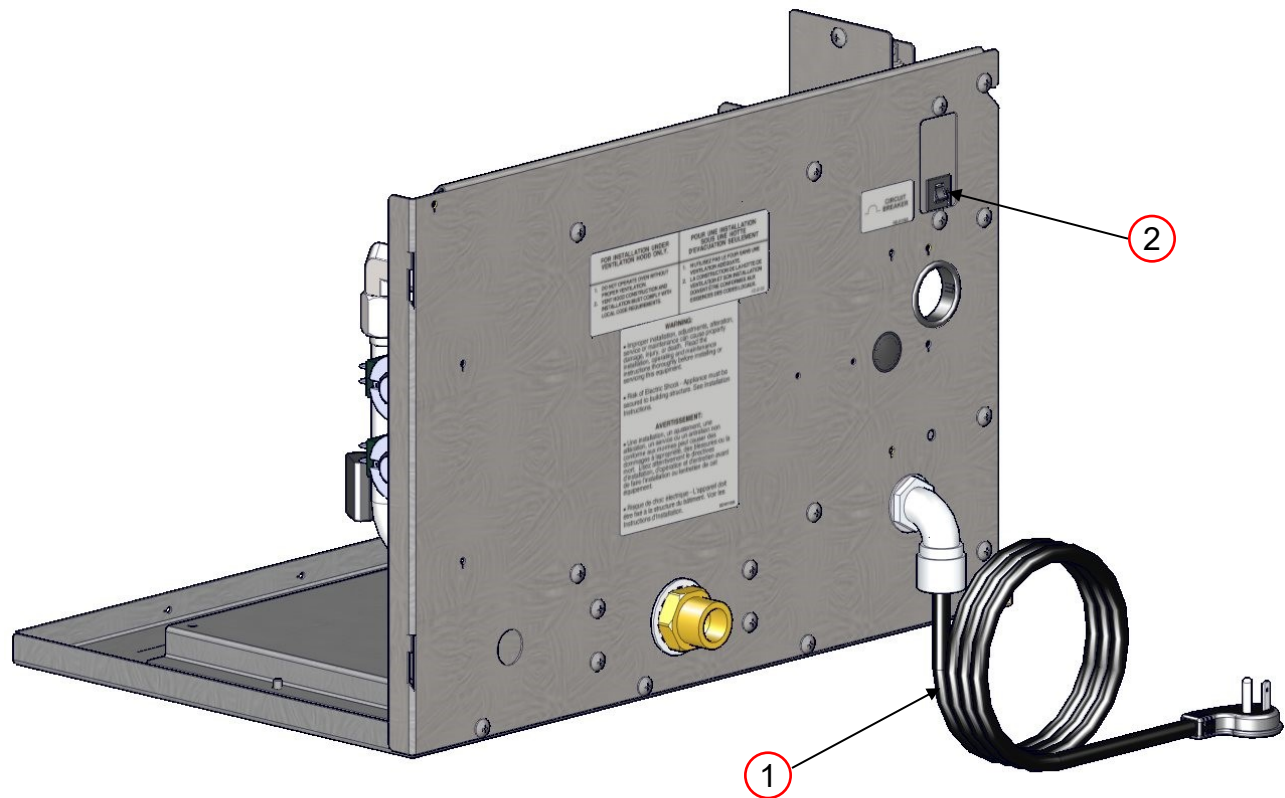

CONTROL BOX REAR		
ITEM	PART NUMBER	DESCRIPTION
1	XA 9301-S	Power Cord Assembly
2	XP 4515-CB-15A	15 Amp Circuit Breaker CB

Control Box Rear information required:

- Size of Oven
- Circuit Breaker amp rating
- Voltage

Integrated Control Package Operating Position (shown with lid removed)

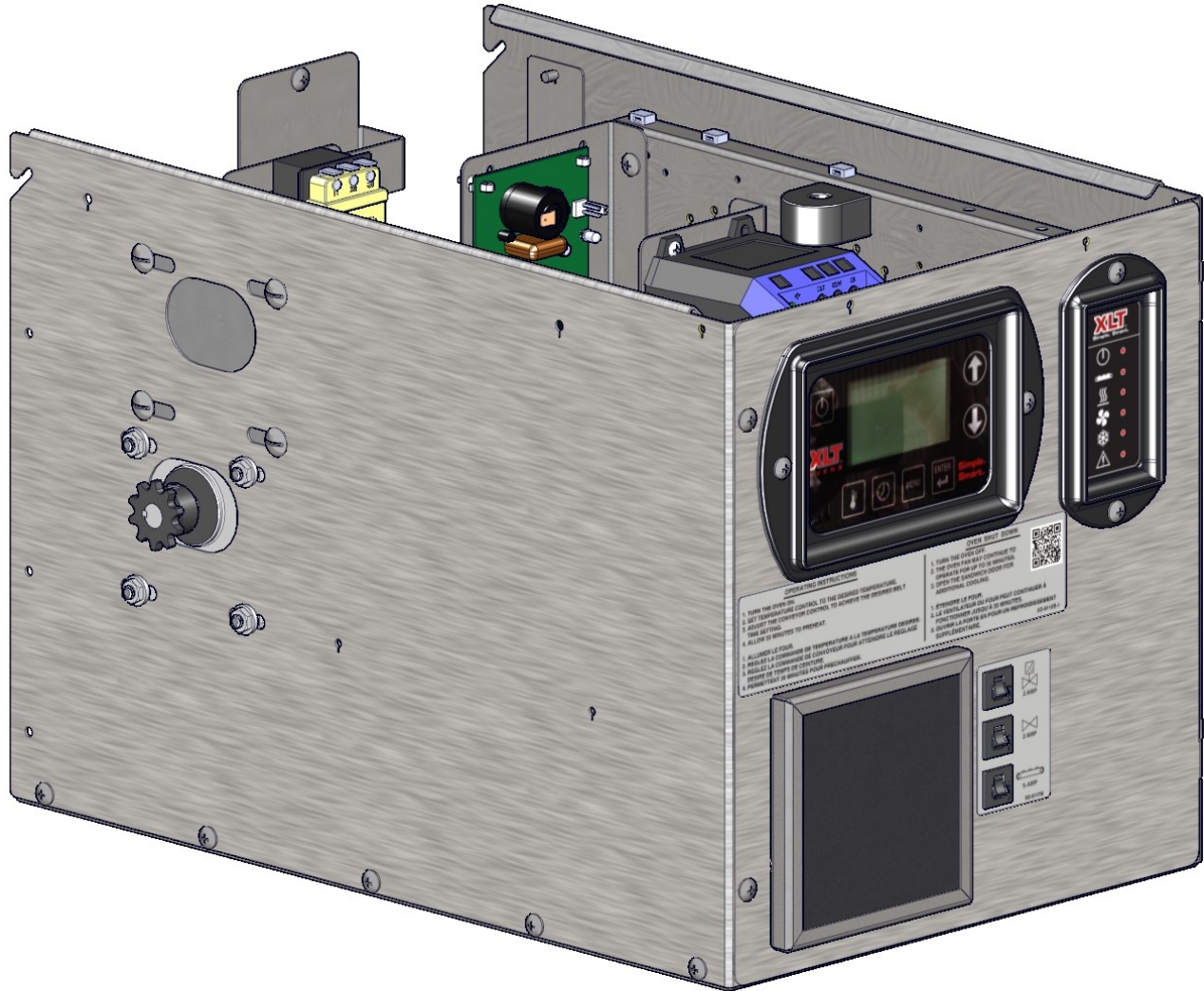

Integrated Control Package Service Position

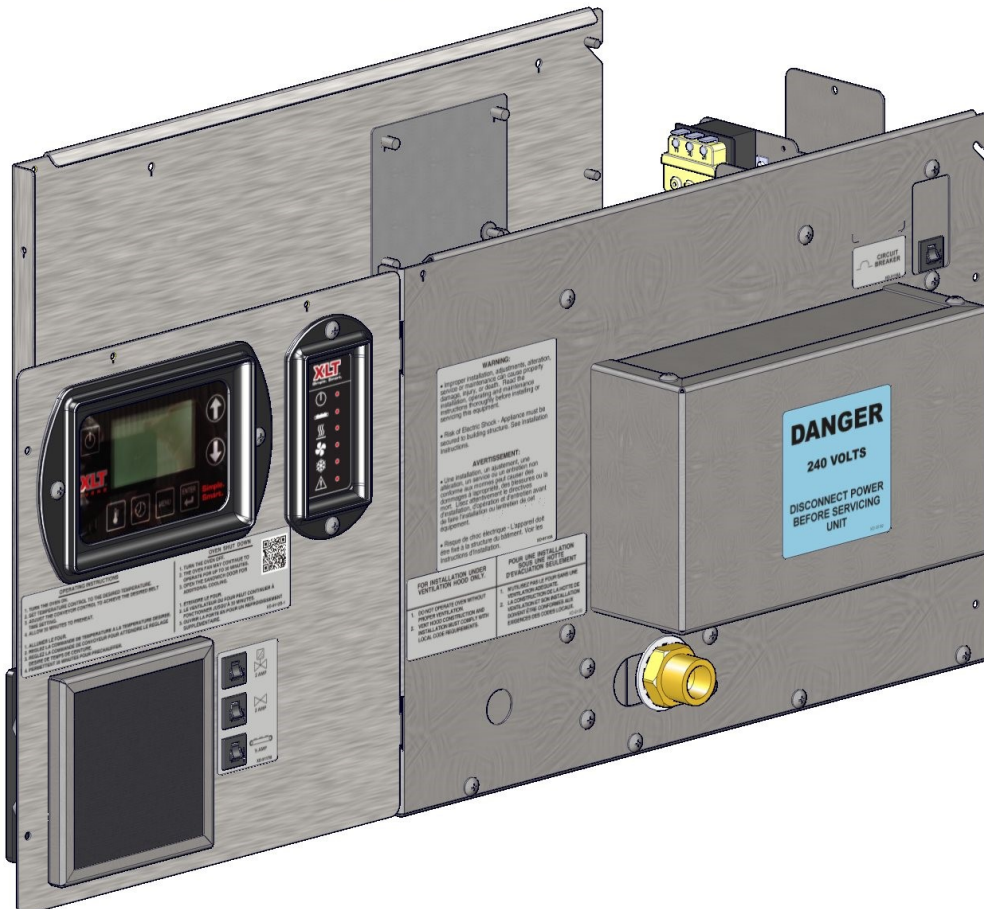
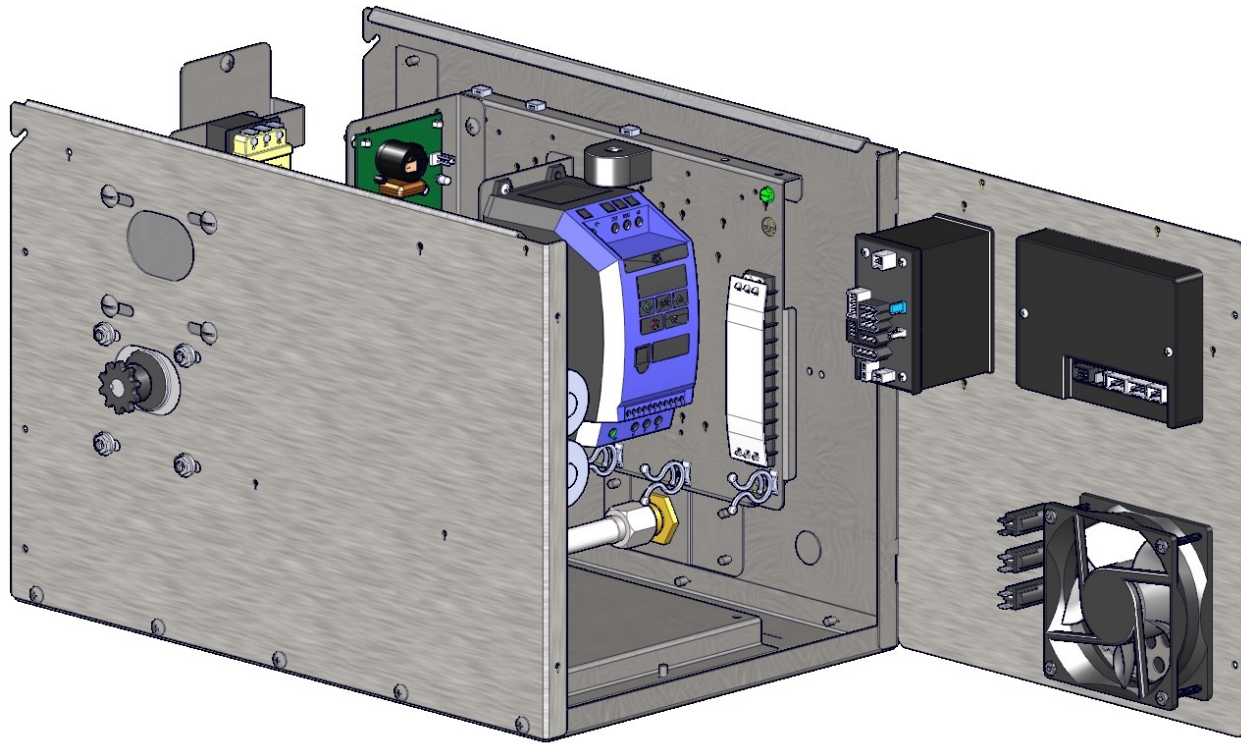

Integrated Control Package



CONTROL PANEL

ITEM	PART NUMBER	DESCRIPTION
1	SP 4520-GA	Fan Guard / Filter Repl Kit GAS
2	XP 4170-LUI	Large User Interface LUI
3	XP 4175-MC	Oven Machine Control OMC
4	XP 4501-GA	FPPG Fan Standard M3
5	XP 4515-CB	Circuit Breaker CB
6	XP 4520-GA	Fan Filter

Control Panel information required:

- Size of Oven
- Voltage
- Circuit Breaker amp rating
- Conveyor Belt direction

Integrated Control Package

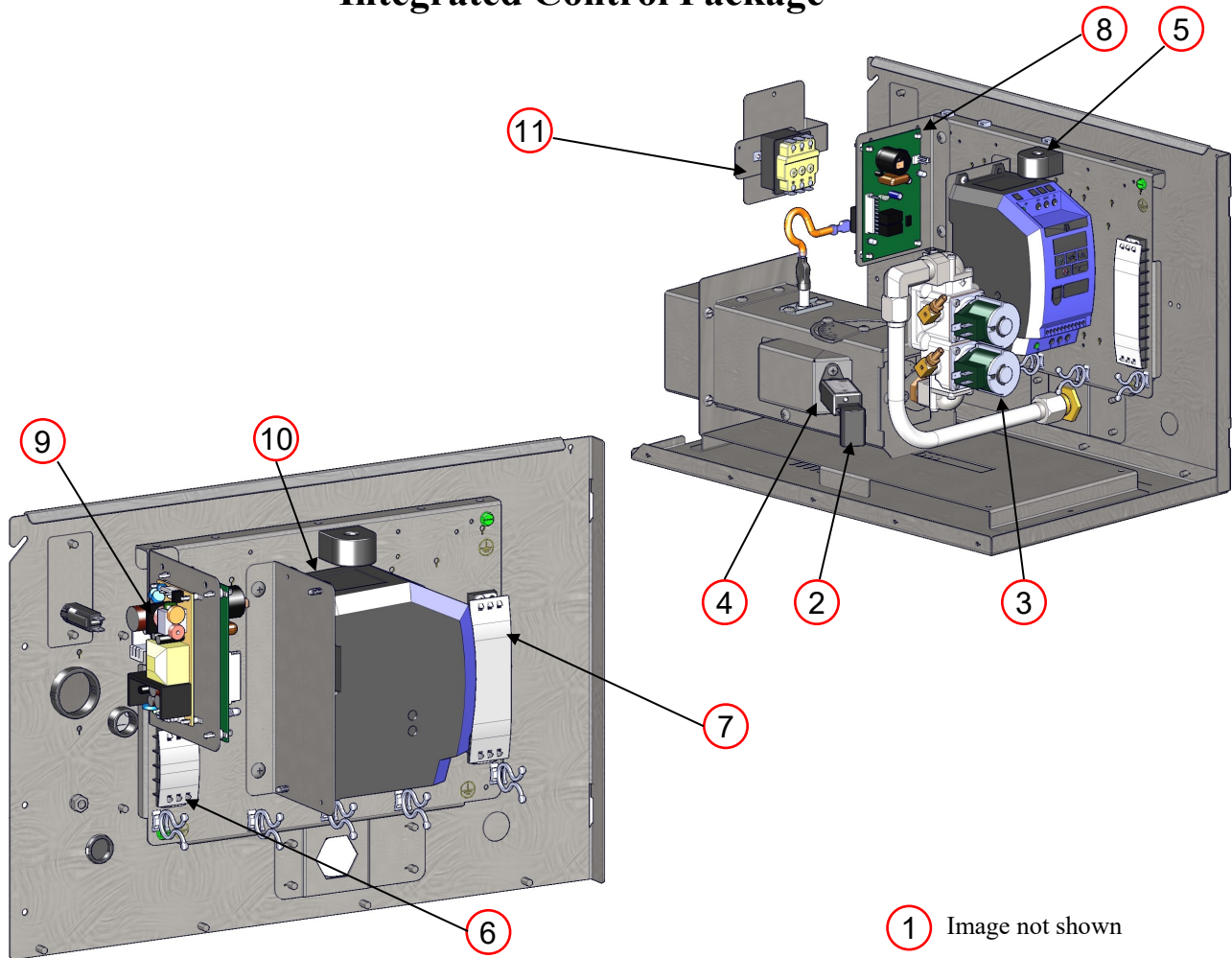

CONTROL BOX INTERIOR		
ITEM	PART NUMBER	DESCRIPTION
1	XH-4117A-Elan	Conveyor Motor Jumper Harness
2	XH 4211-DC	UV Flame Sensor Wire Plug
3	XP 4207-DI-N/P	Gas Valve V1-V2
4	XP 4210-UV-DC	Flame Sensor FS
5	XP 4310	Current Sensor
6	XP 4701-04	Terminal Strip 4 Place TS
7	XP 4701-10	Terminal Strip 10 Place TS
8	XP 4705-DI-24	Ignition Control IC
9	RP 4717	Power Supply PS
10	XP 4718-4.3	VFD Invertex Optidrive E3
11	XP 4723A	High Temp Limit Switch (S3)

Control Box Back information required:

- Size of Oven
- Voltage

Integrated Control Package

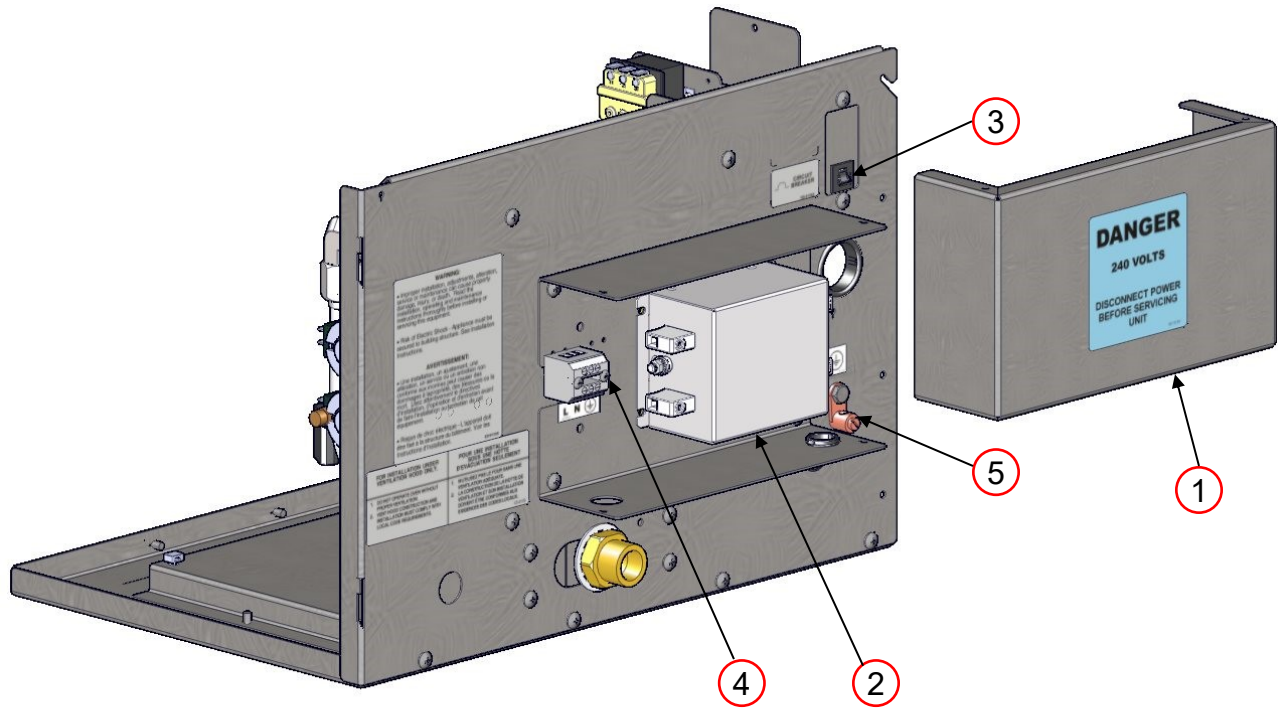

CONTROL BOX REAR		
ITEM	PART NUMBER	DESCRIPTION
1	XM 9303	Power Inlet Box Cover
2	XP 4313	EMI Power Filter FLT1
3	XP 4515-CB-7A	7 Amp Circuit Breaker CB
4	XP 4702-03-W	Terminal Strip 3 Pole TS
5	XP 4707	Ground Lug Copper World

Control Box Rear information required:

- Size of Oven
- Circuit Breaker amp rating
- Voltage

**Integrated Control Package
Operating Position (shown with lid removed)**

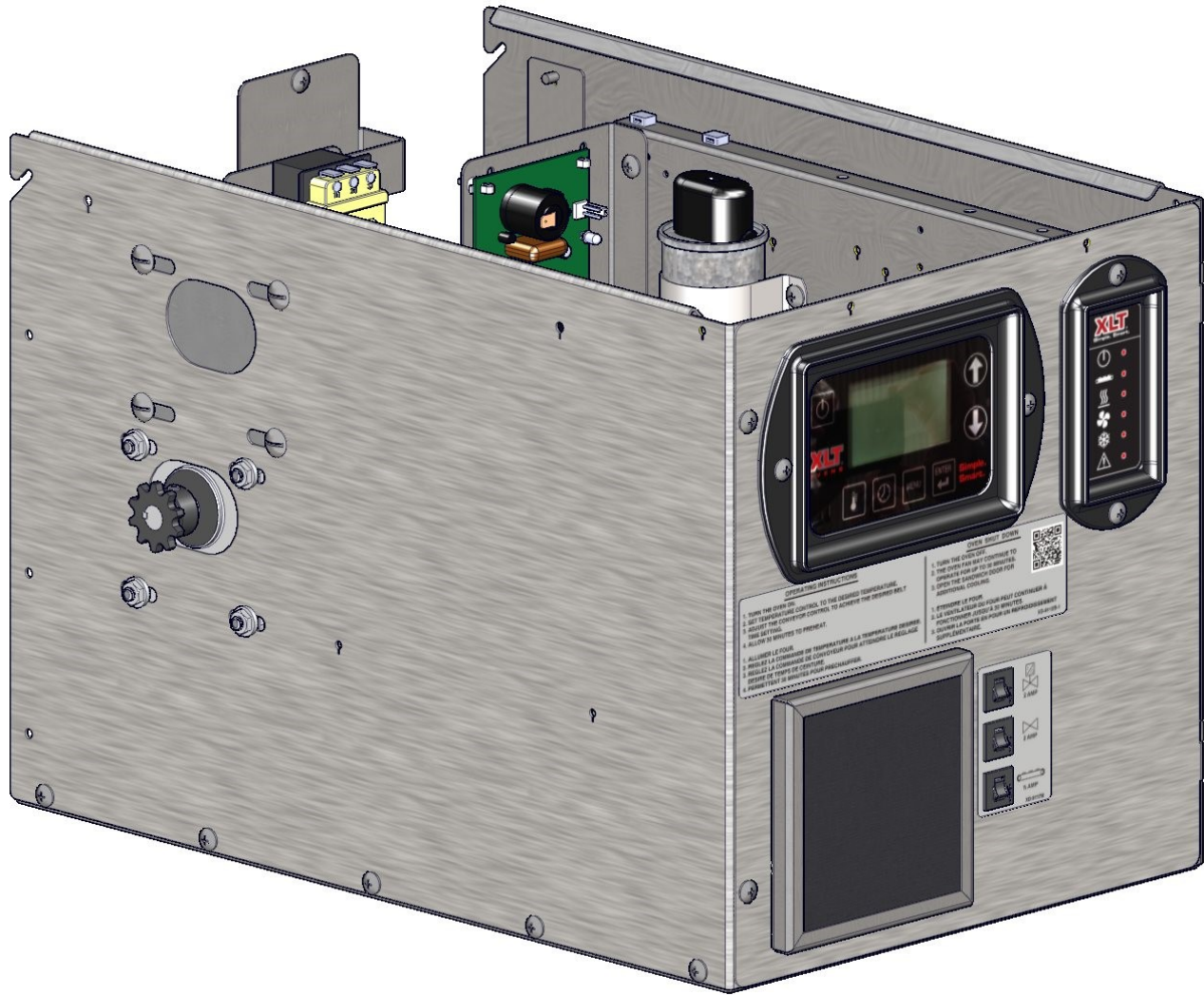

Integrated Control Package Service Position

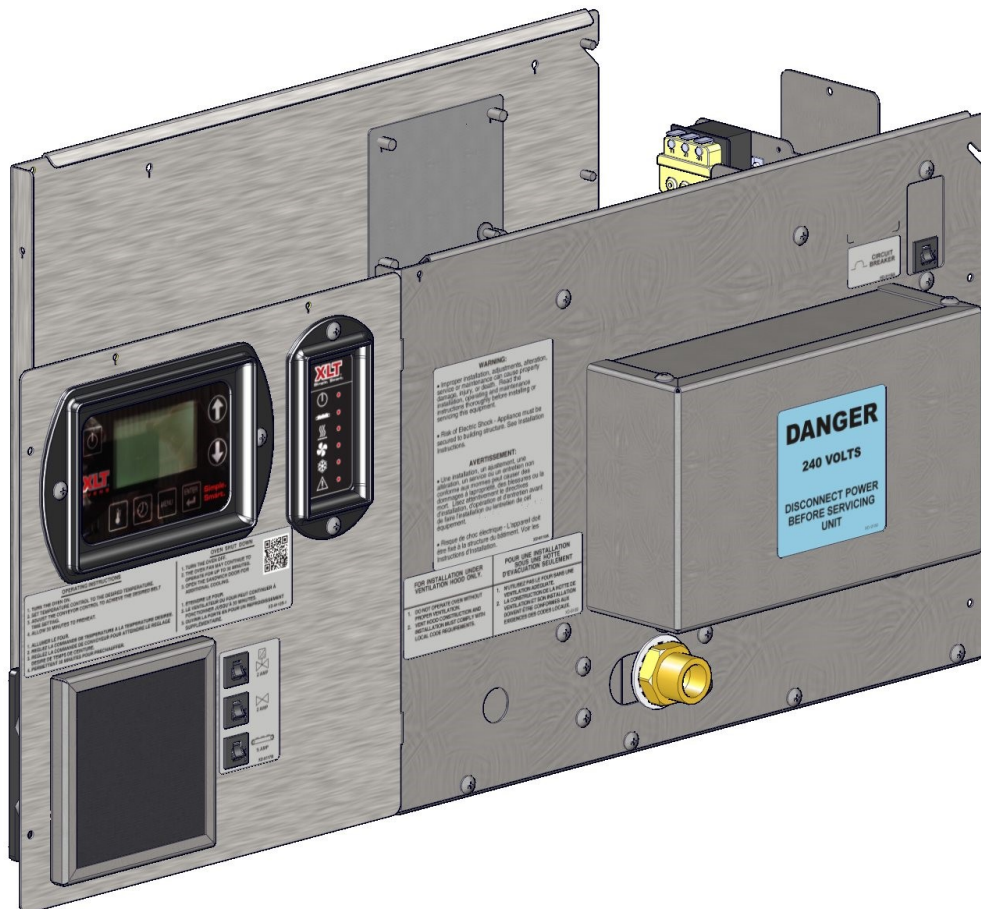
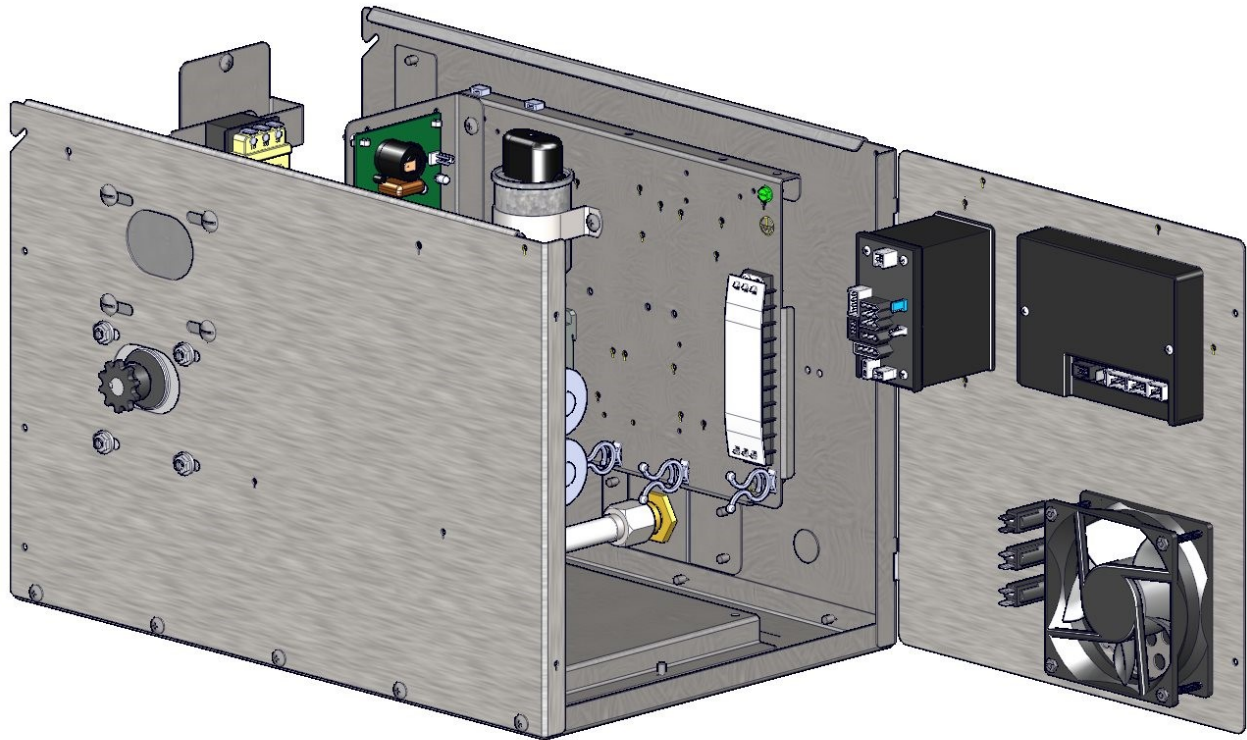

Integrated Control Package

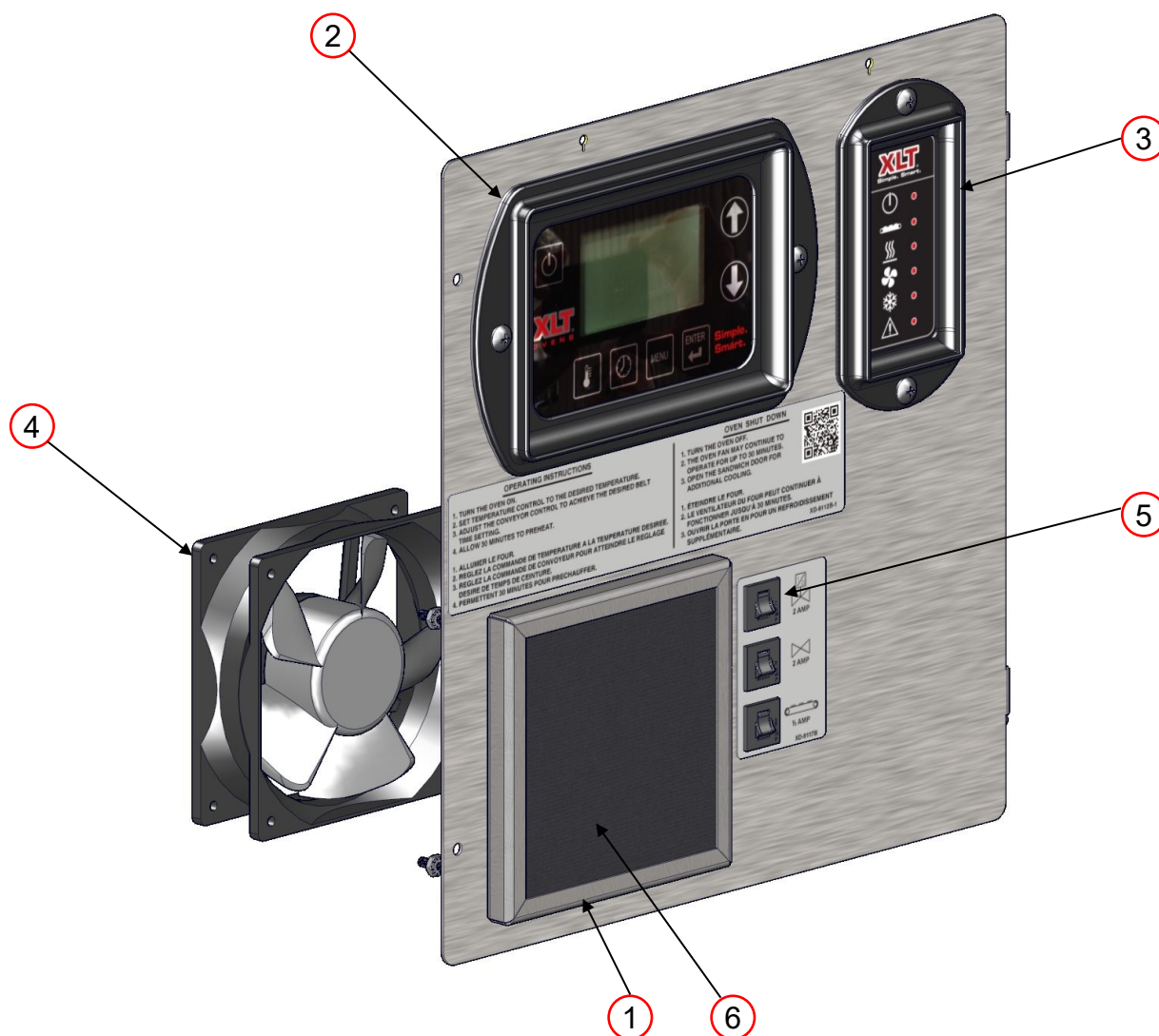

CONTROL PANEL		
ITEM	PART NUMBER	DESCRIPTION
1	SP 4520-GA	Fan Guard / Filter Repl Kit GAS
2	XP 4170-LUI	Large User Interface LUI
3	XP 4175-MC	Oven Machine Control OMC
4	XP 4501-GA	FPPG Fan Standard M3
5	XP 4515-CB	Circuit Breaker CB
6	XP 4520-GA	Fan Filter

Control Panel information required:

- Size of Oven
- Voltage
- Circuit Breaker amp rating
- Conveyor Belt direction

Integrated Control Package

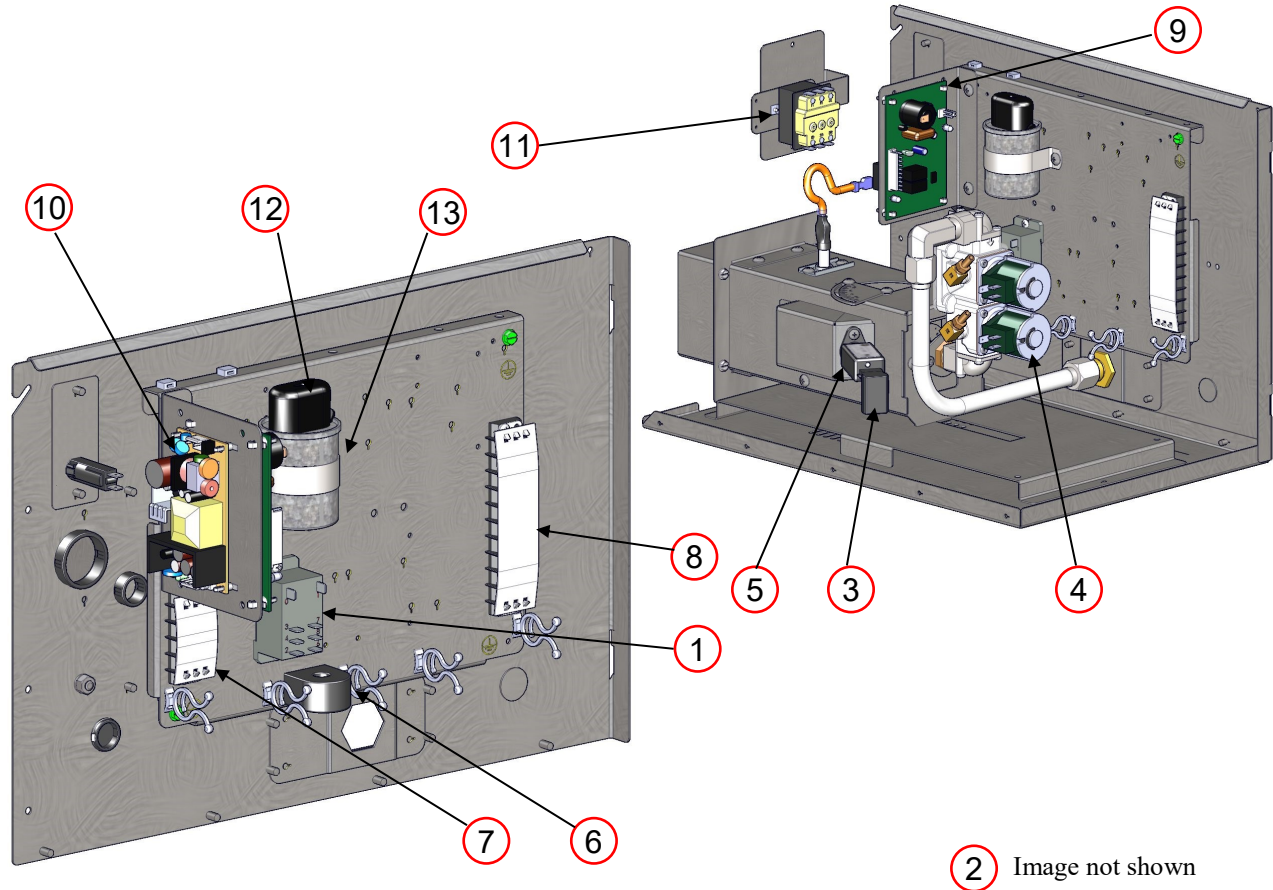

World Control Box non VFD - Integrated Control Package

CONTROL BOX INTERIOR		
ITEM	PART NUMBER	DESCRIPTION
1	HP 2067-24VDC	Oven Fan Motor Relay R1
2	XH-4117A-Elan	Conveyor Motor Jumper Harness
3	XH 4211-DC	UV Flame Sensor Wire Plug
4	XP 4207-DI-N/P	Gas Valve V1-V2
5	XP 4210-UV-DC	Flame Sensor FS
6	XP 4310	Current Sensor CS
7	XP 4701-04	Terminal Strip 4 Place TS
8	XP 4701-10	Terminal Strip 10 Place TS
9	XP 4705-DI-24	Ignition Control IC
10	RP 4717	Power Supply PS
11	XP 4723A	High Temp Switch
12	XP 5012	Capacitor Boot

Control Box Back information required:

- Size of Oven
- Voltage

Integrated Control Package

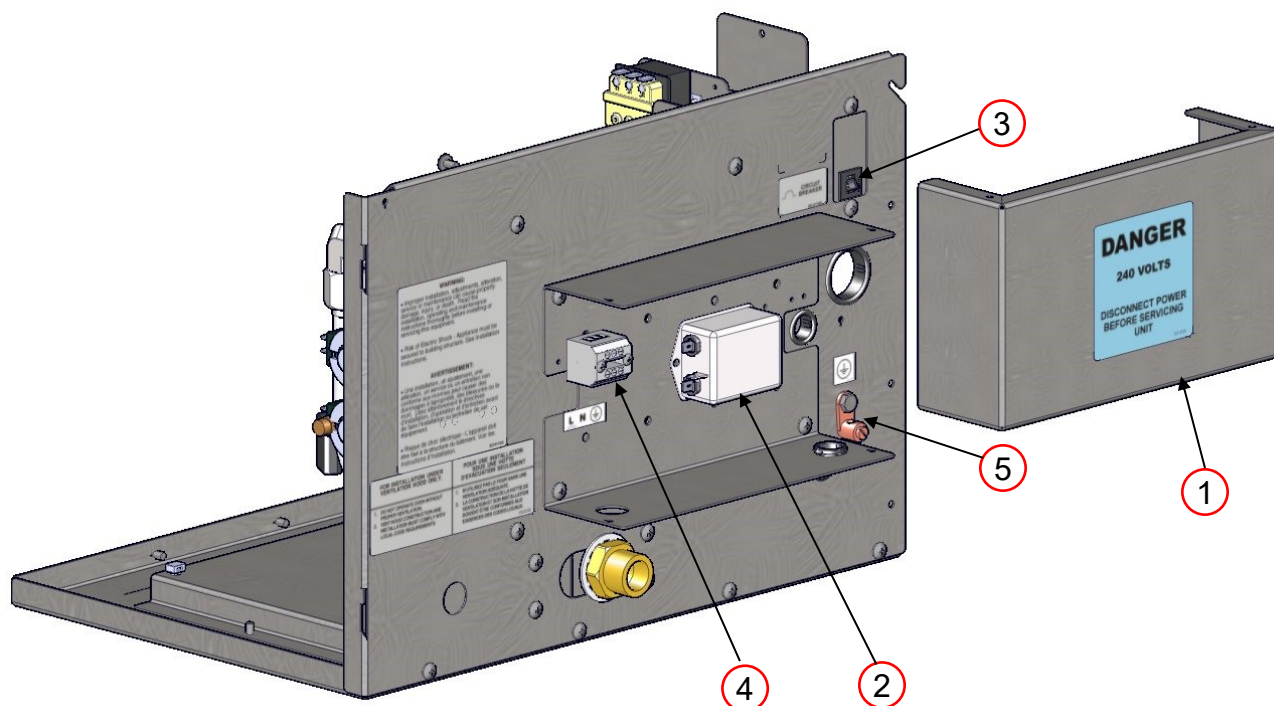

CONTROL BOX REAR		
ITEM	PART NUMBER	DESCRIPTION
1	XM 9303	Power Inlet Box Cover
2	XP 4320	EMI Power Filter FLT1
3	XP 4515-CB-7A	7 Amp Circuit Breaker CB
4	XP 4702-03-W	Terminal Strip 3 Pole TS
5	XP 4707	Ground Lug Copper World

Control Box Rear information required:

- Size of Oven
- Circuit Breaker amp rating
- Voltage

Operating Position (shown with lid removed)

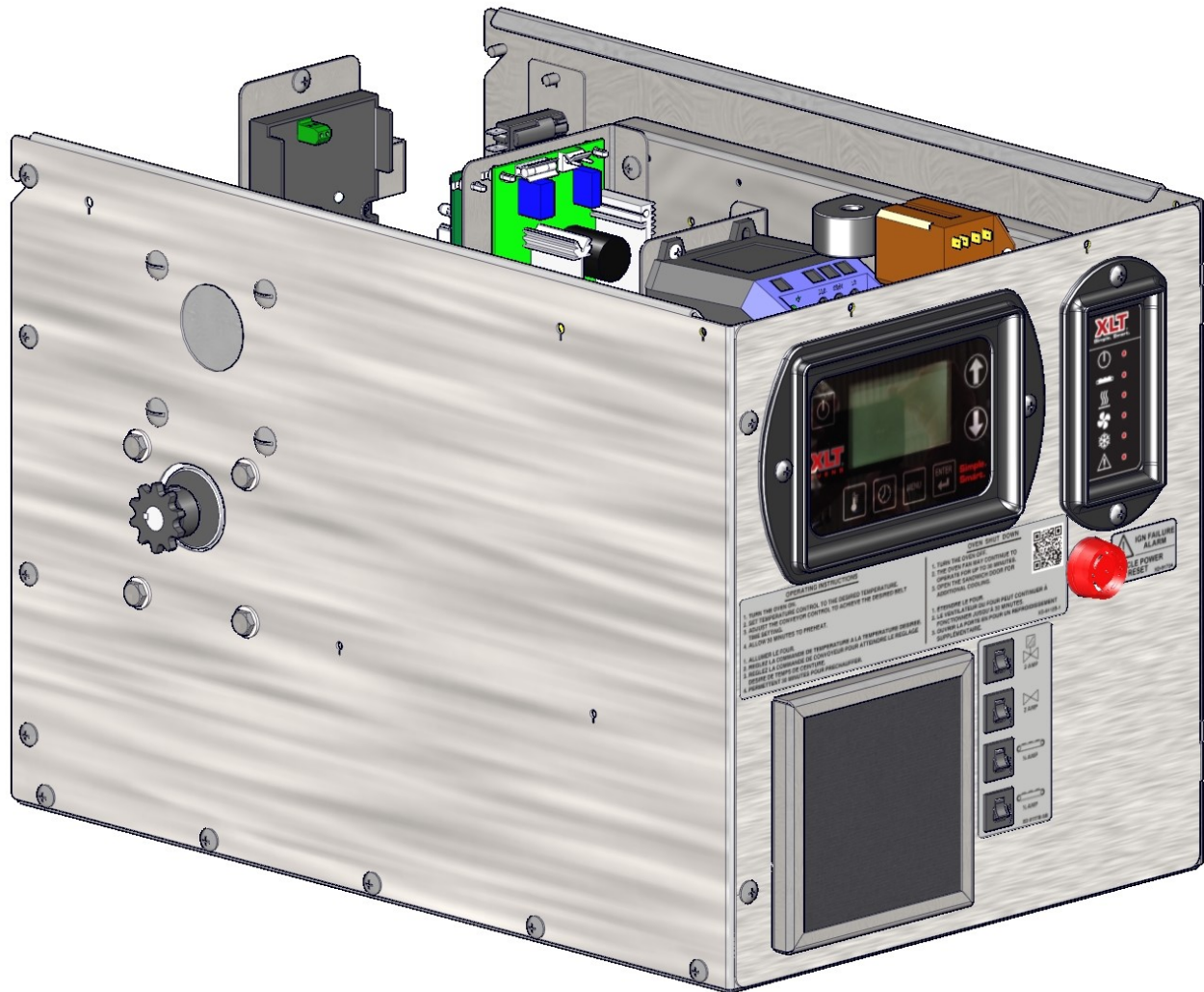

Service Position

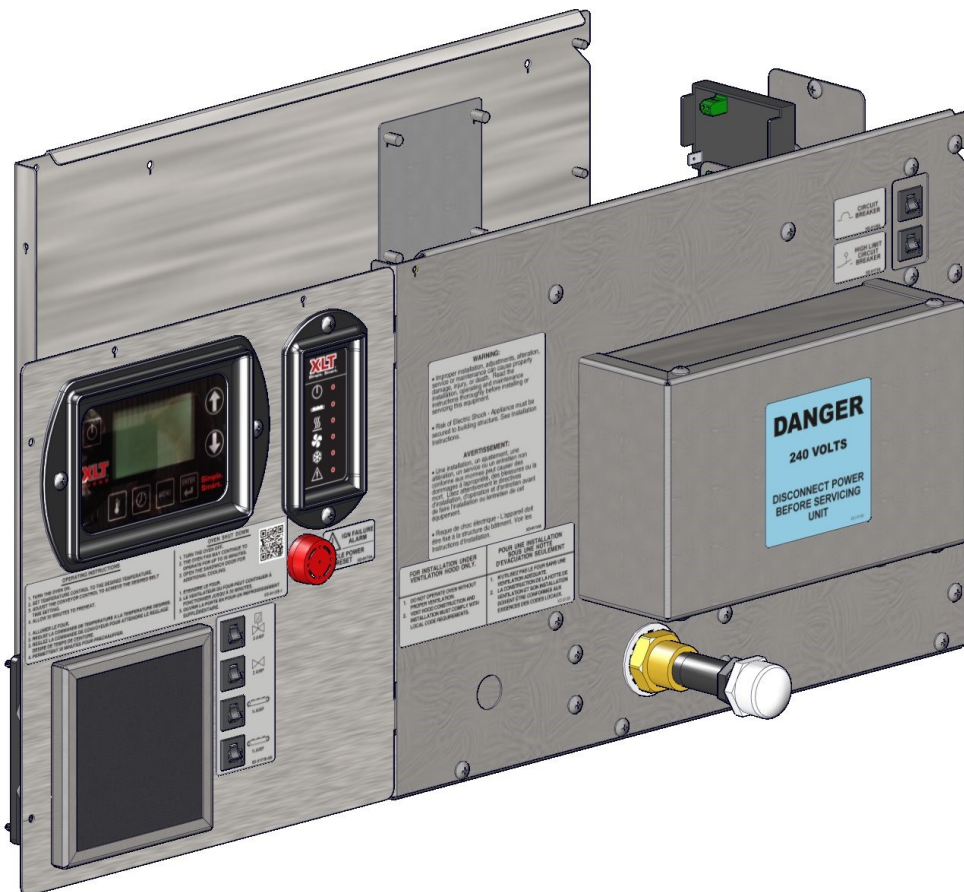
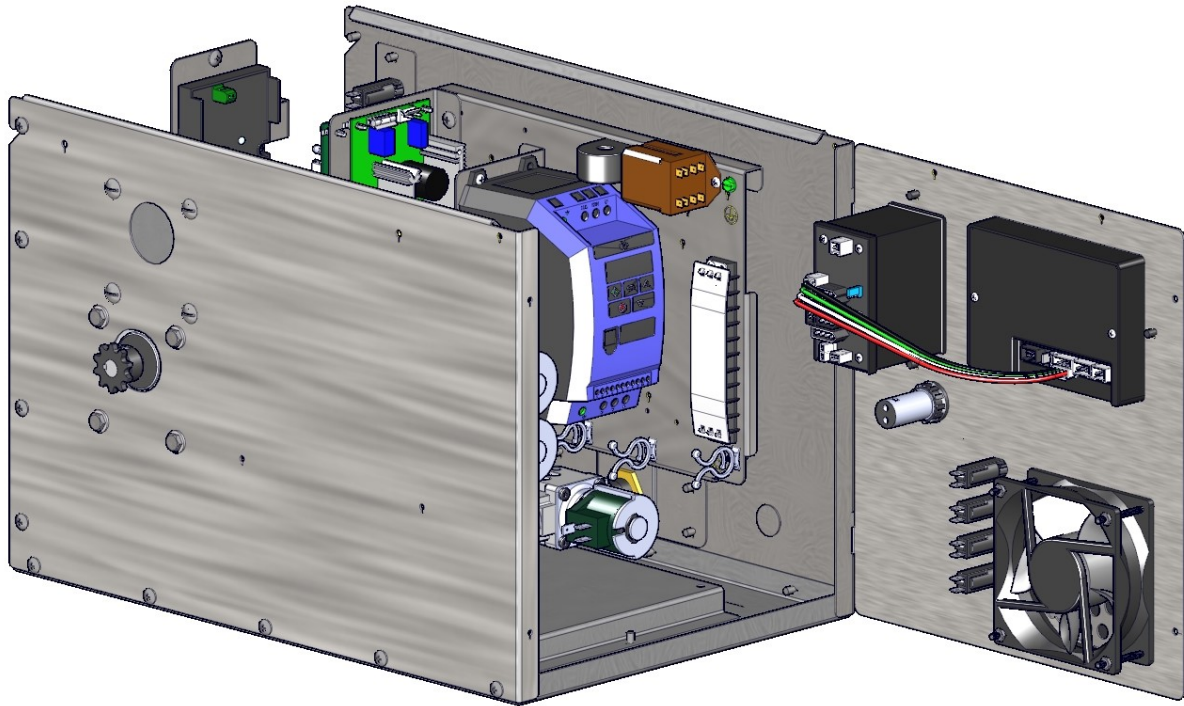



CONTROL PANEL

ITEM	PART NUMBER	DESCRIPTION
1	HP 2063	Alarm And Buzzer AL
2	SP 4520-GA	Fan Guard / Filter Repl Kit GAS
3	XP 4170-LUI	Large User Interface LUI
4	XP 4175-MC	Oven Machine Control OMC
5	XP 4501-GA	FPPG Fan Standard M3
6	XP 4515-CB	Circuit Breaker CB
7	XP 4520-GA	Fan Filter

Control Panel information required:

- Size of Oven
- Voltage
- Circuit Breaker amp rating
- Conveyor Belt direction

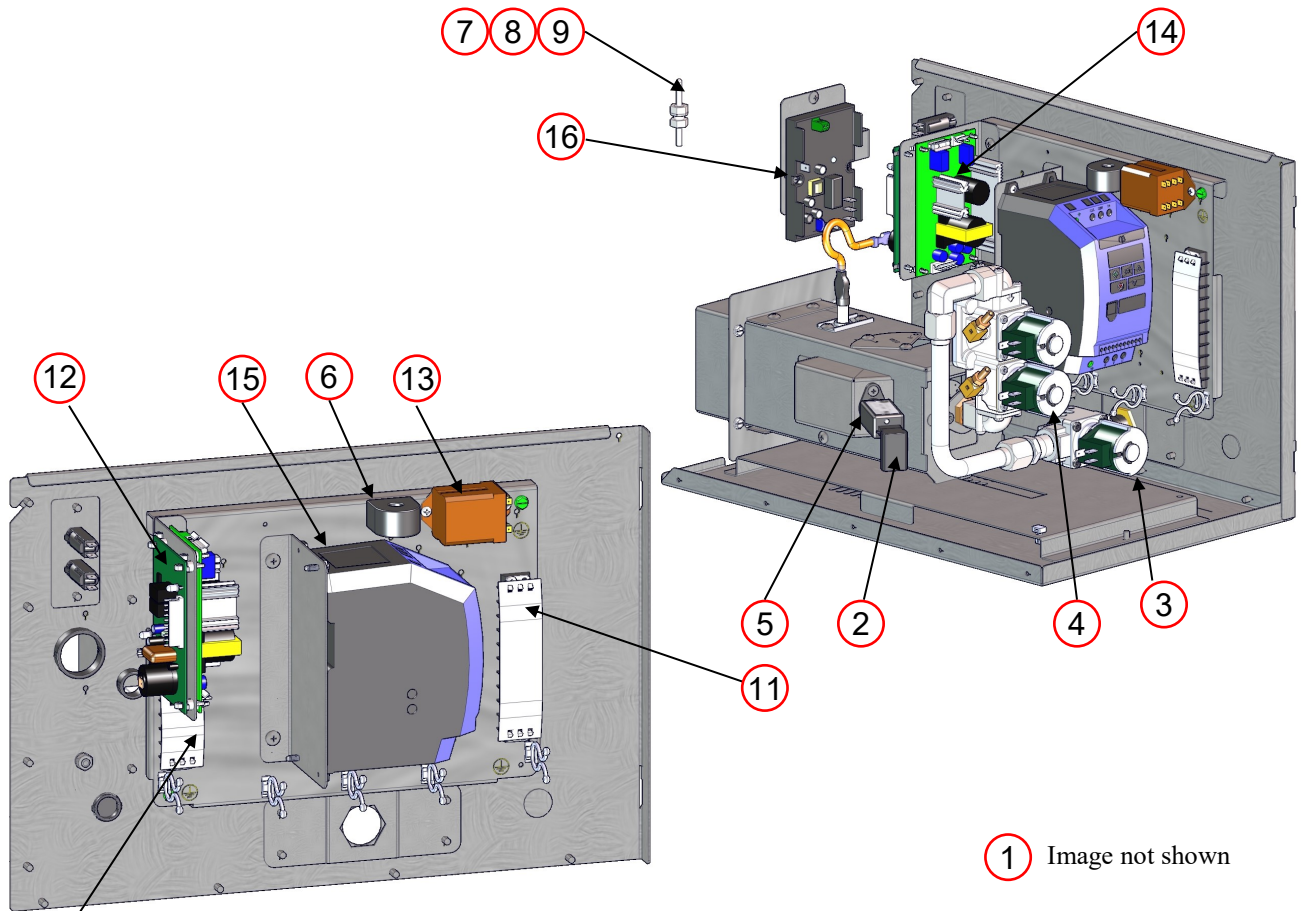

CONTROL BOX INTERIOR		
ITEM	PART NUMBER	DESCRIPTION
1	XH-4117A-Elan	Conveyor Motor Jumper Harness
2	XH 4211-DC	UV Flame Detector Wire Plug
3	XP 4207-DI-AE	Shut-Off Valve V3
4	XP 4207-DI-N/P	Gas Valve V1-V2
5	XP 4210-UV-DC	Flame Sensor FS
6	XP 4310	Current Sensor
7	XP 4509-90	Thermocouple Type K 39 TC
8	XP 4510-90	Thermocouple Type K 90 TC
9	XP 4512	RTD Class B Element
10	XP 4701-04	Terminal Strip 4 Place TS
11	XP 4701-10	Terminal Strip 10 Place TS
12	XP 4705-DI-24	Ignition Control IC
13	XP 4715	Proving Relay R2
14	XP 4716	Power Supply PS
15	XP 4718-4.3	VFD Invertex Optidrive E3
16	XP 4723A-Elan	Elan High Limit Switch S3

Control Box Back information required:

- Size of Oven
- Voltage

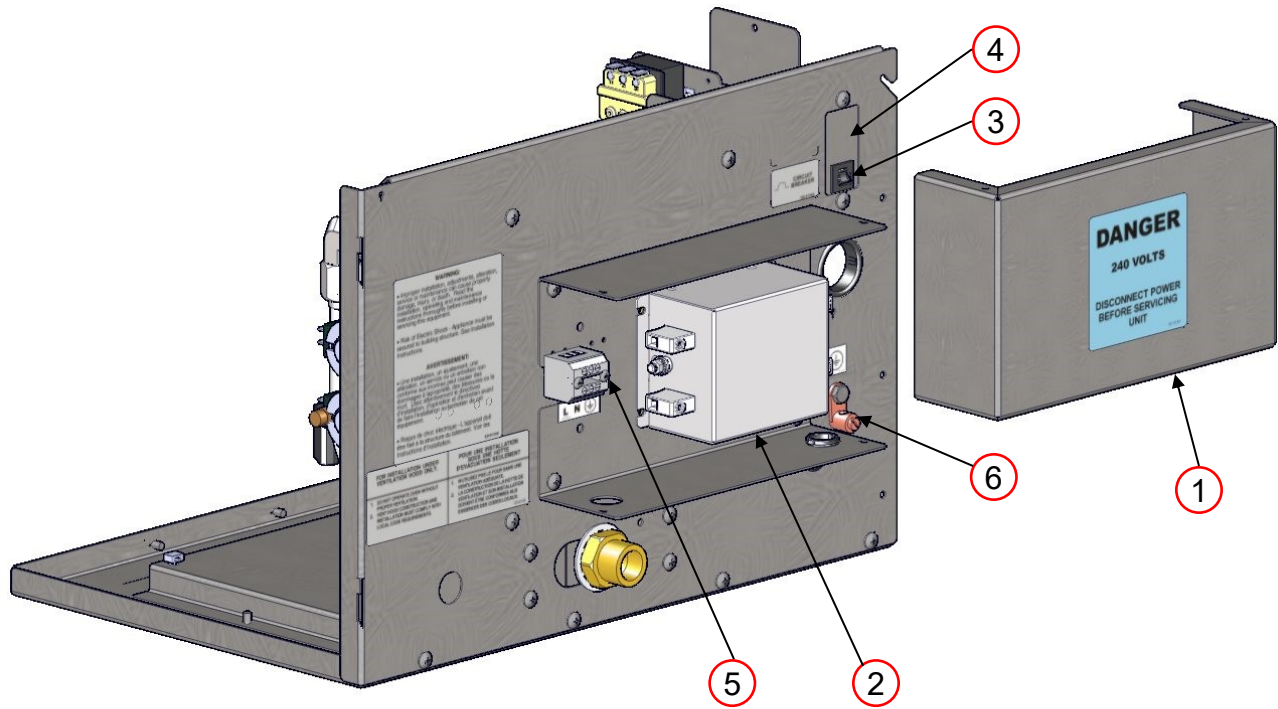

CONTROL BOX REAR		
ITEM	PART NUMBER	DESCRIPTION
1	XM 9303	Power Inlet Box Cover
2	XP 4313	EMI Power Filter FLT1
3	XP 4515-CB-0.5A	1/2 Amp Circuit Breaker CB
4	XP 4515-CB-10A	10 Amp Circuit Breaker CB
5	XP 4702-03-W	Terminal Strip 3 Pole TS
6	XP 4707	Ground Lug Copper World

Control Box Rear information required:

- Size of Oven
- Circuit Breaker amp rating
- Voltage

Operating Position (shown with lid removed)

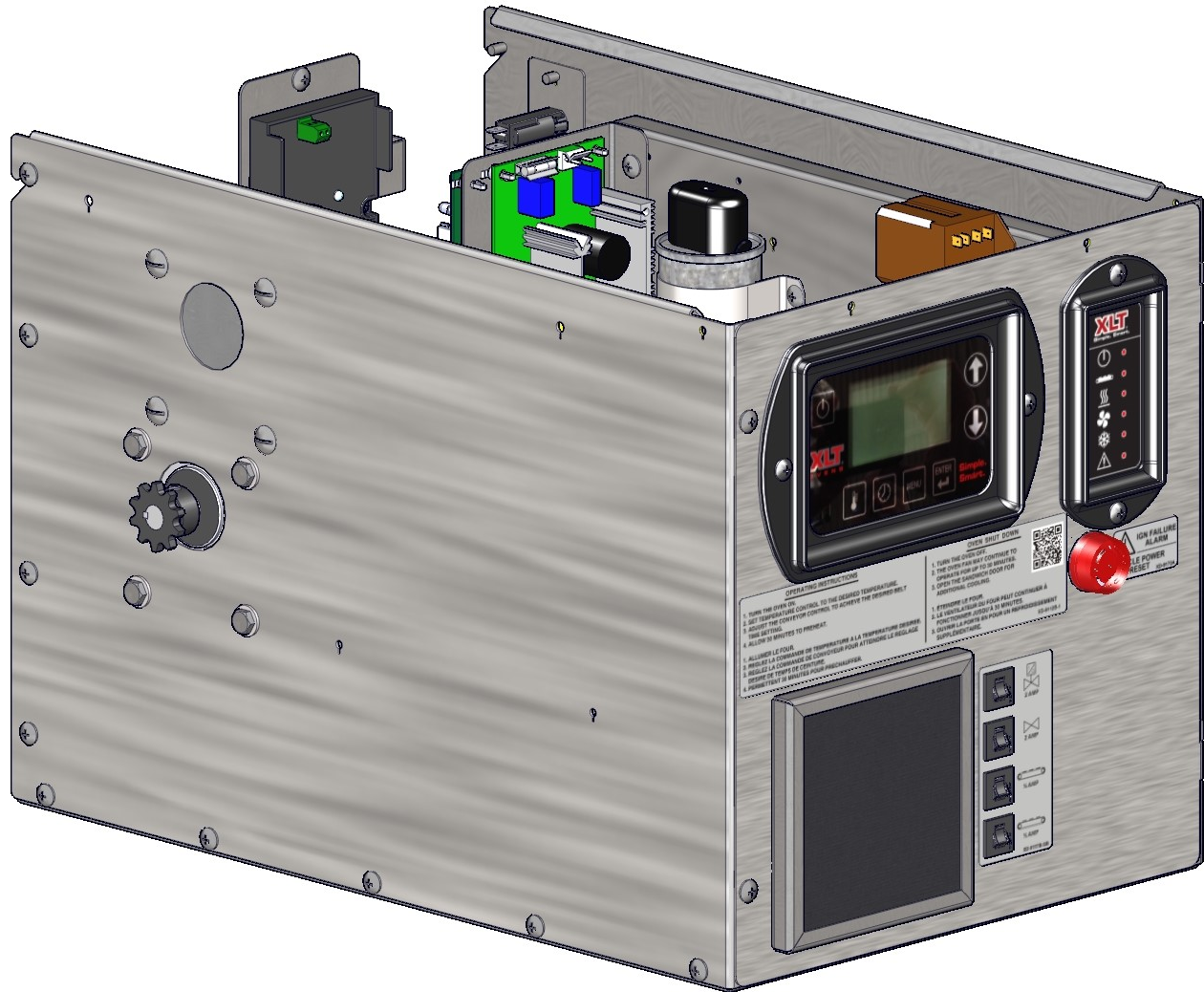

Service Position

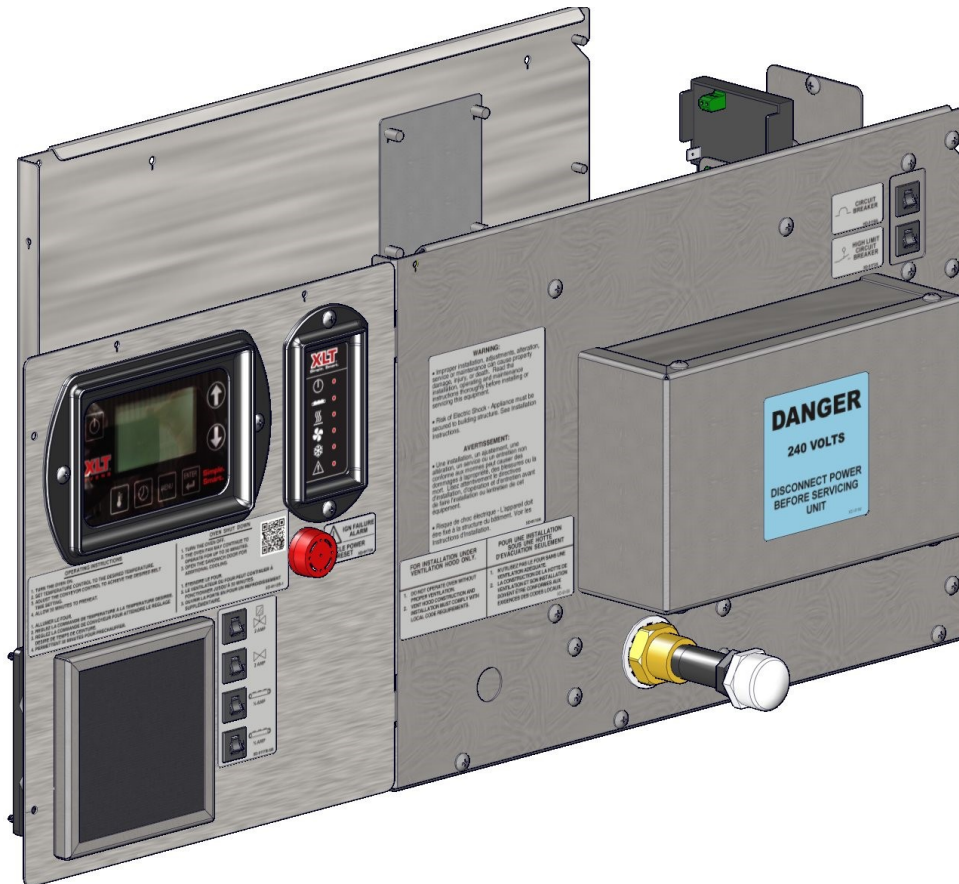
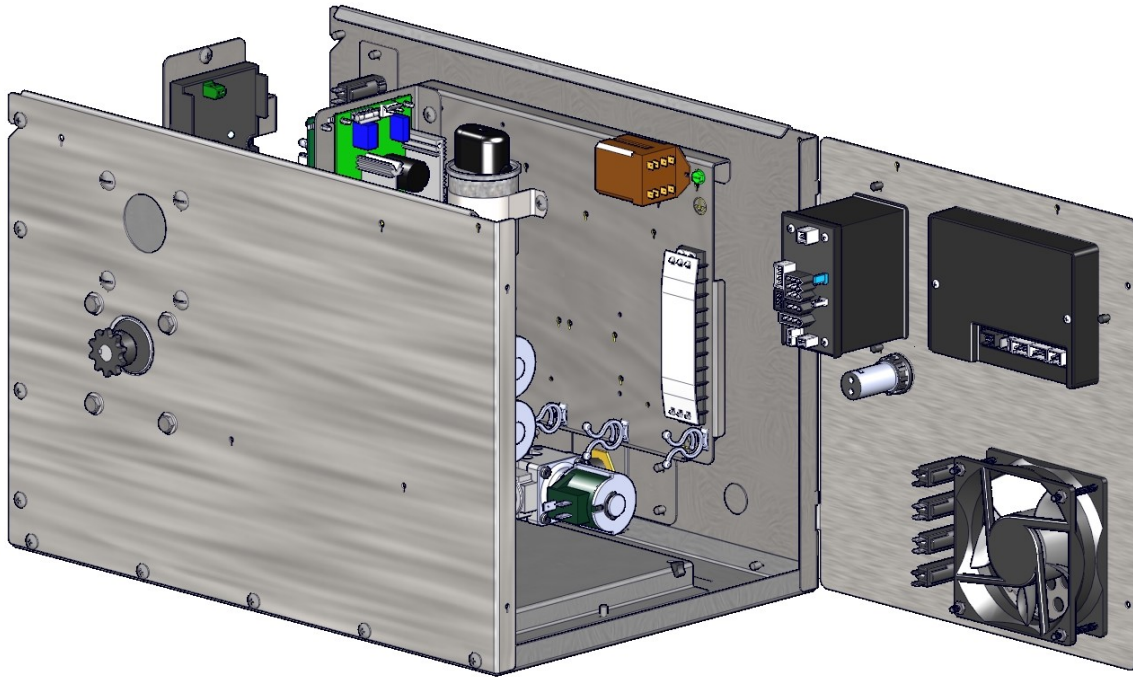



CONTROL PANEL		
ITEM	PART NUMBER	DESCRIPTION
1	HP 2063	Alarm And Buzzer AL
2	SP 4520-GA	Fan Guard / Filter Repl Kit GAS
3	XP 4170-LUI	Large User Interface LUI
4	XP 4175-MC	Oven Machine Control OMC
5	XP 4501-GA	FPPG Fan Standard M3
6	XP 4515-CB	Circuit Breaker CB
7	XP 4520-GA	Fan Filter

Control Panel information required:

- Size of Oven
- Voltage
- Circuit Breaker amp rating
- Conveyor Belt direction

78 OVEN PARTS - AUSTRALIA CONTROL BOX NON VFD

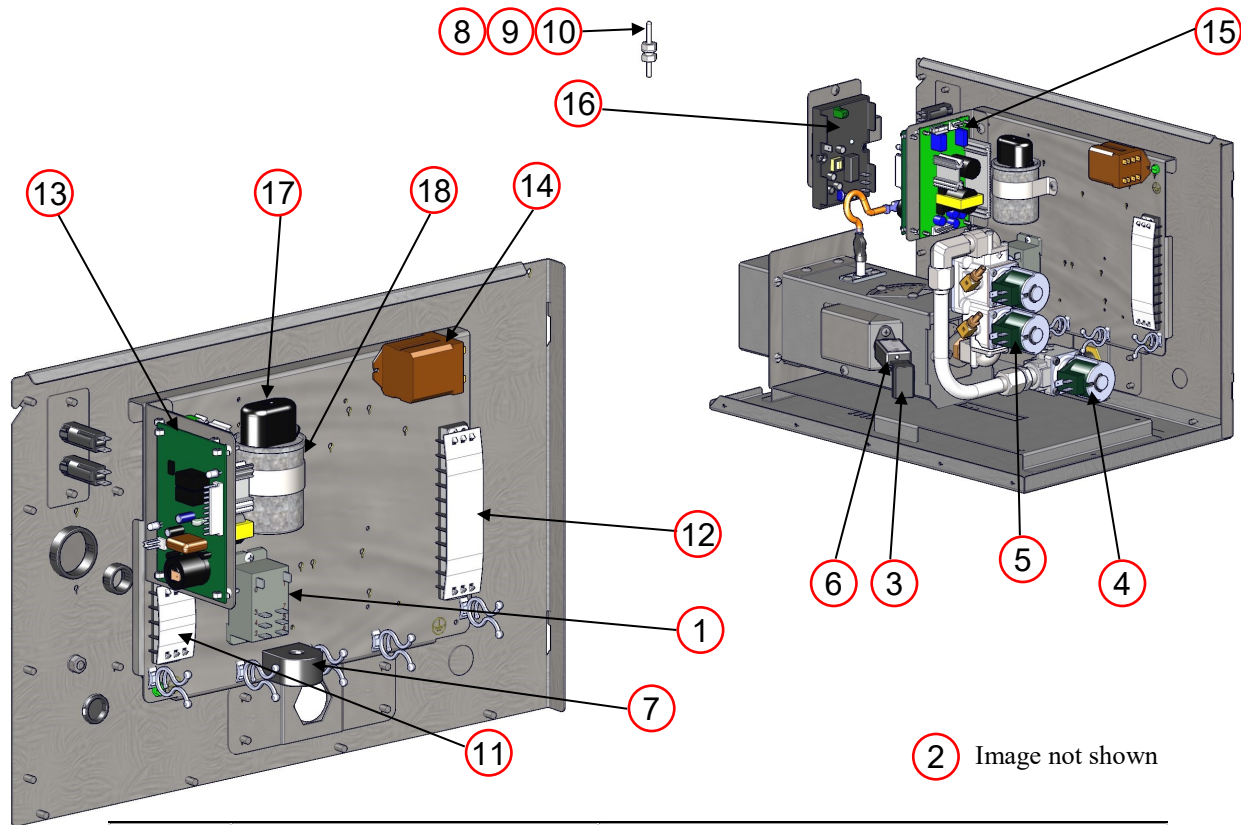

Australia Control Box non VFD		
CONTROL BOX INTERIOR		
ITEM	PART NUMBER	DESCRIPTION
1	XP 2067-24VDC	Relay 8 Pin 30A 24 VDC
2	XH-4117A-Elan	Conveyor Motor Jumper Harness
3	XH 4211-DC	UV Flame Detector Wire Plug
4	XP 4207-DI-AE	Shut-Off Valve V3
5	XP 4207-DI-N/P	Gas Valve V1-V2
6	XP 4210-UV-DC	Flame Sensor FS
7	XP 4310	Current Sensor CS
8	XP 4509-90	Thermocouple Type K 39 TC
9	XP 4510-90	Thermocouple Type K 90 TC
10	XP 4512	RTD Class B Element
11	XP 4701-04	Terminal Strip 4 Place TS
12	XP 4701-10	Terminal Strip 10 Place TS
13	XP 4705-DI-24	Ignition Control IC
14	XP 4715	Proving Relay R2
15	XP 4716	Power Supply PS
16	XP 4723A-Elan	Elan High Limit Switch S3

Control Box Back information required:

- Size of Oven
- Voltage

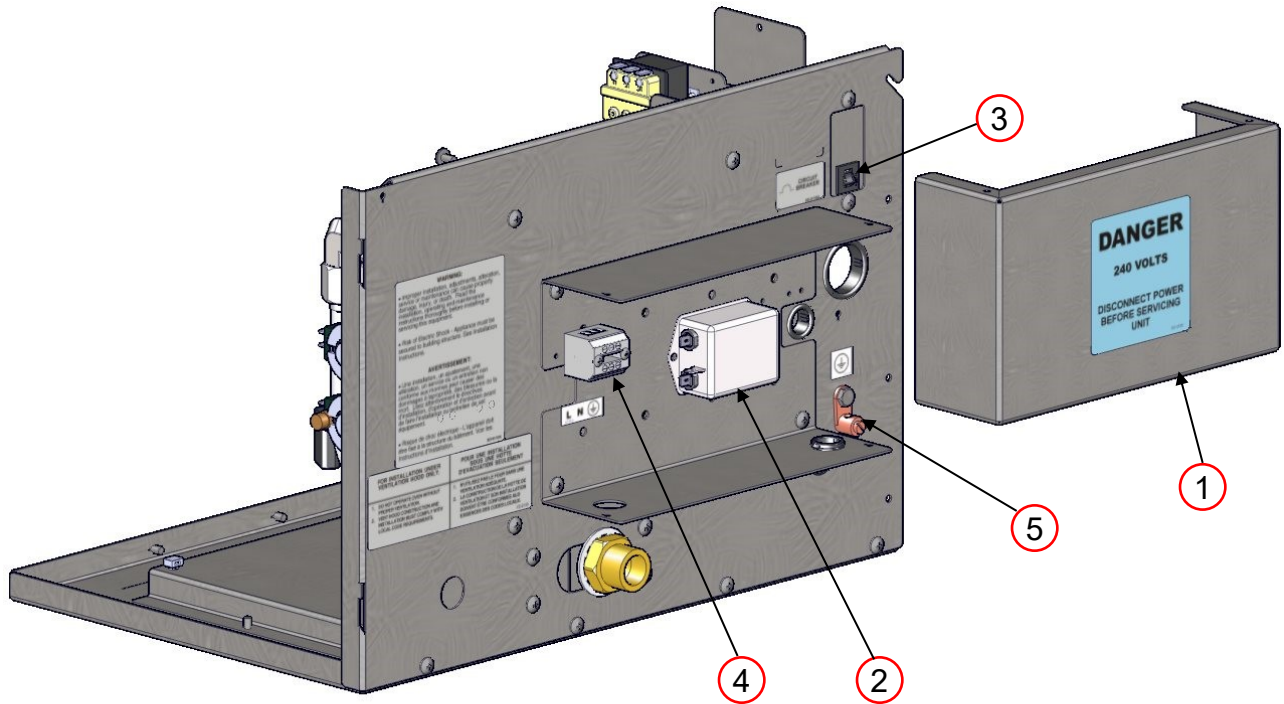

CONTROL BOX REAR		
ITEM	PART NUMBER	DESCRIPTION
1	XM 9303	Power Inlet Box Cover
2	XP 4320	EMI Power Filter FLT1
3	XP 4515-CB-7A	7 Amp Circuit Breaker CB
4	XP 4702-03-W	Terminal Strip 3 Pole TS
5	XP 4707	Ground Lug Copper World

Control Box Rear information required:

- Size of Oven
- Circuit Breaker amp rating
- Voltage

**Discrete Control Package
Operating Position (shown with lid removed)**

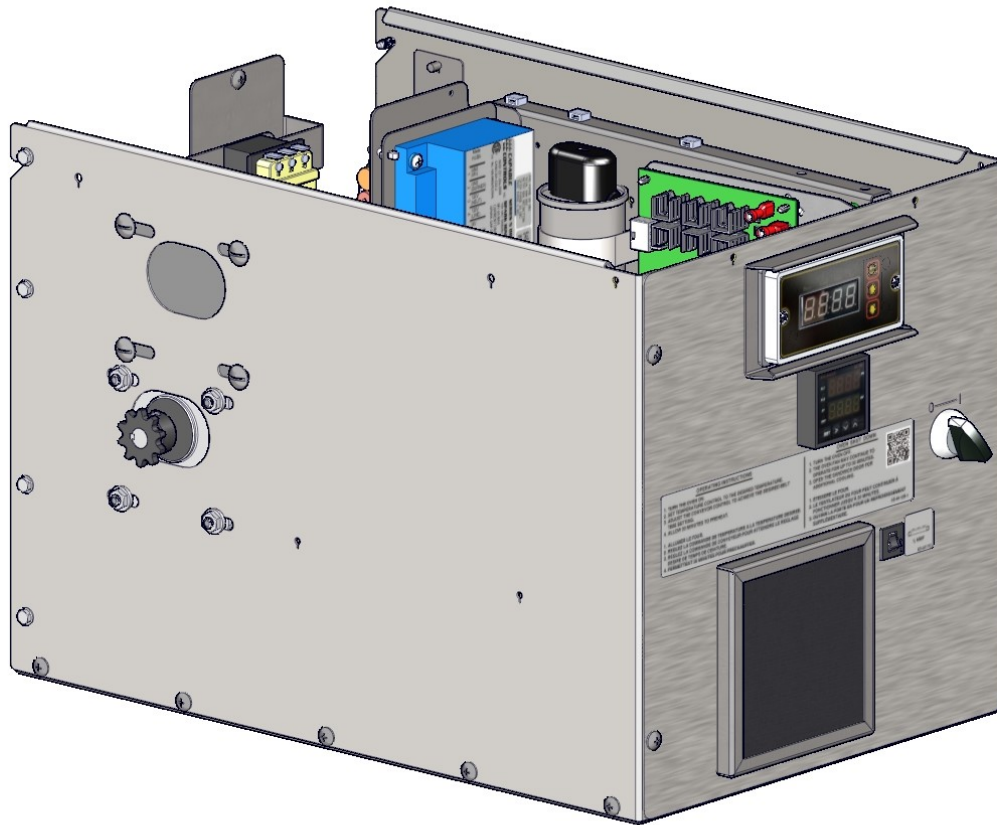

**Discrete Control Package
Service Position**

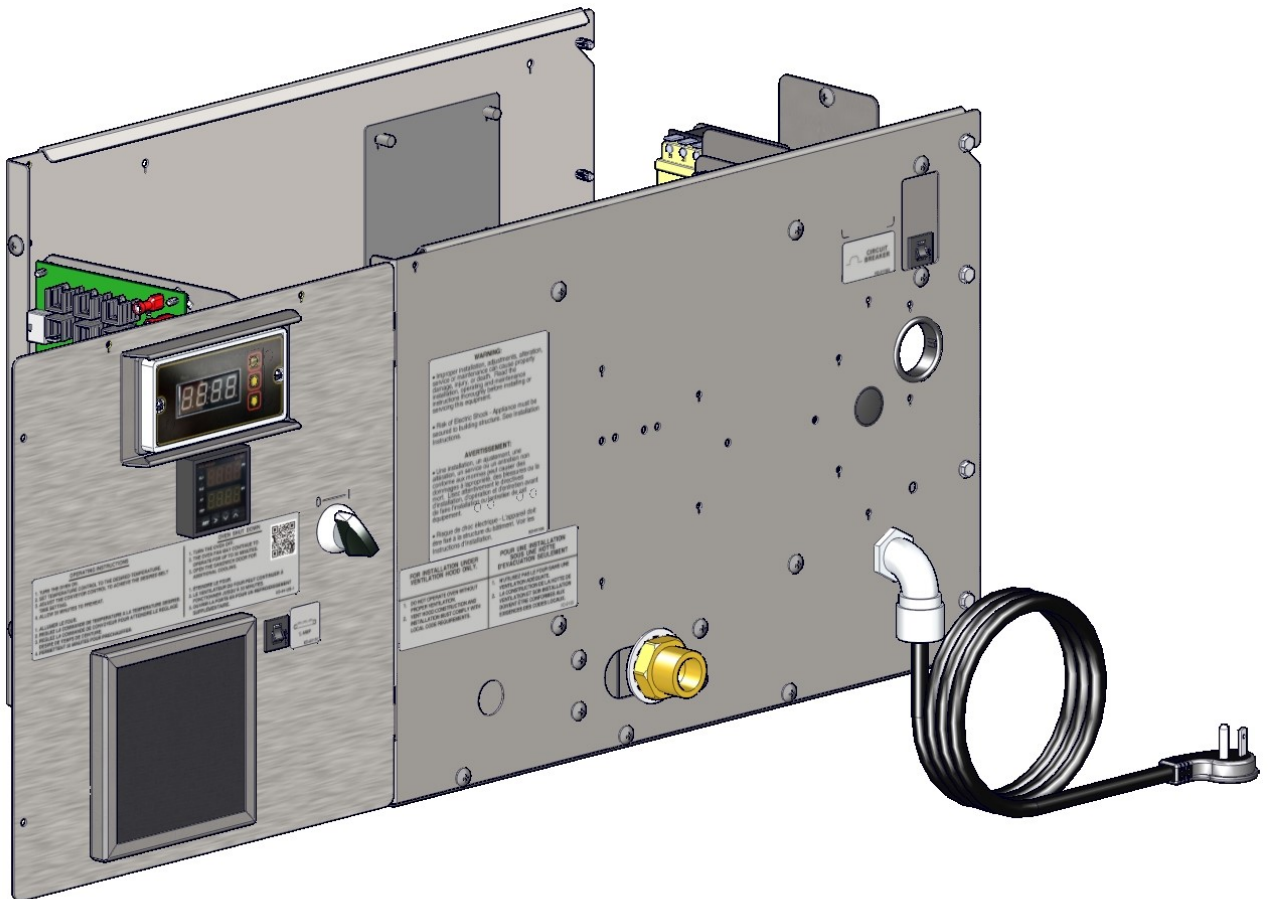
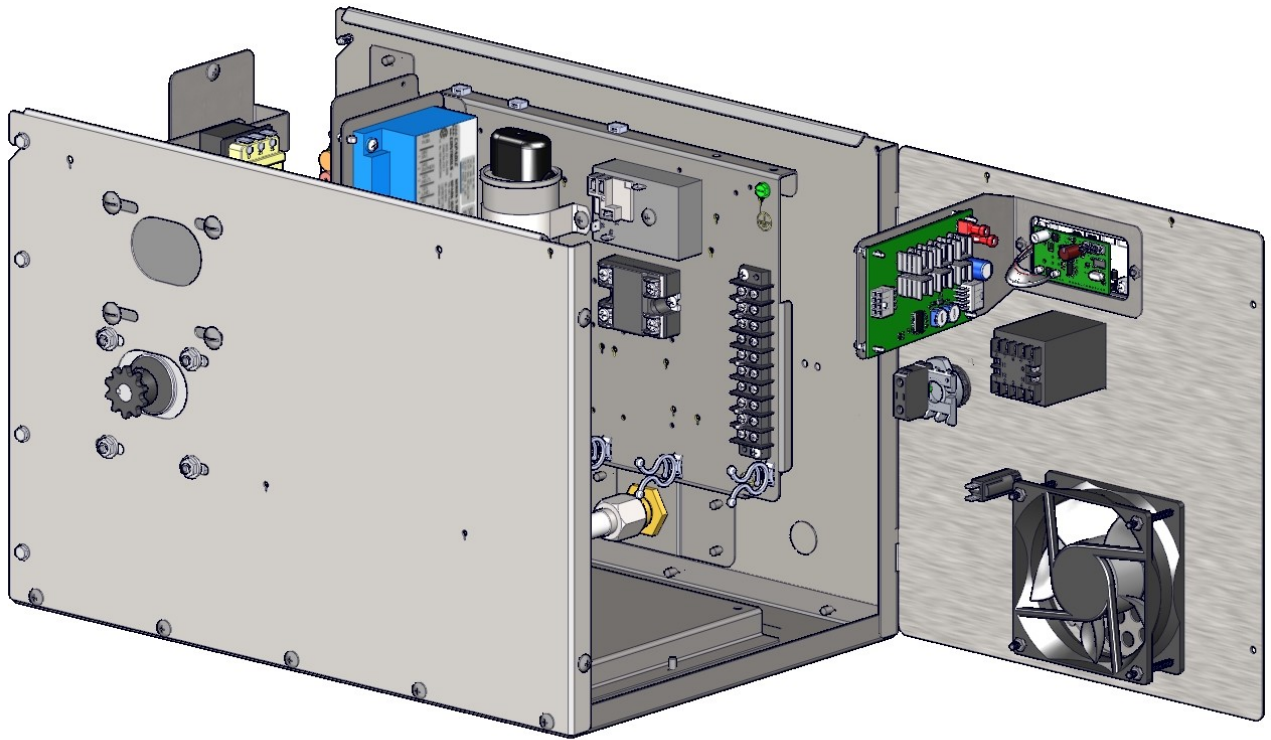

Discrete Control Package

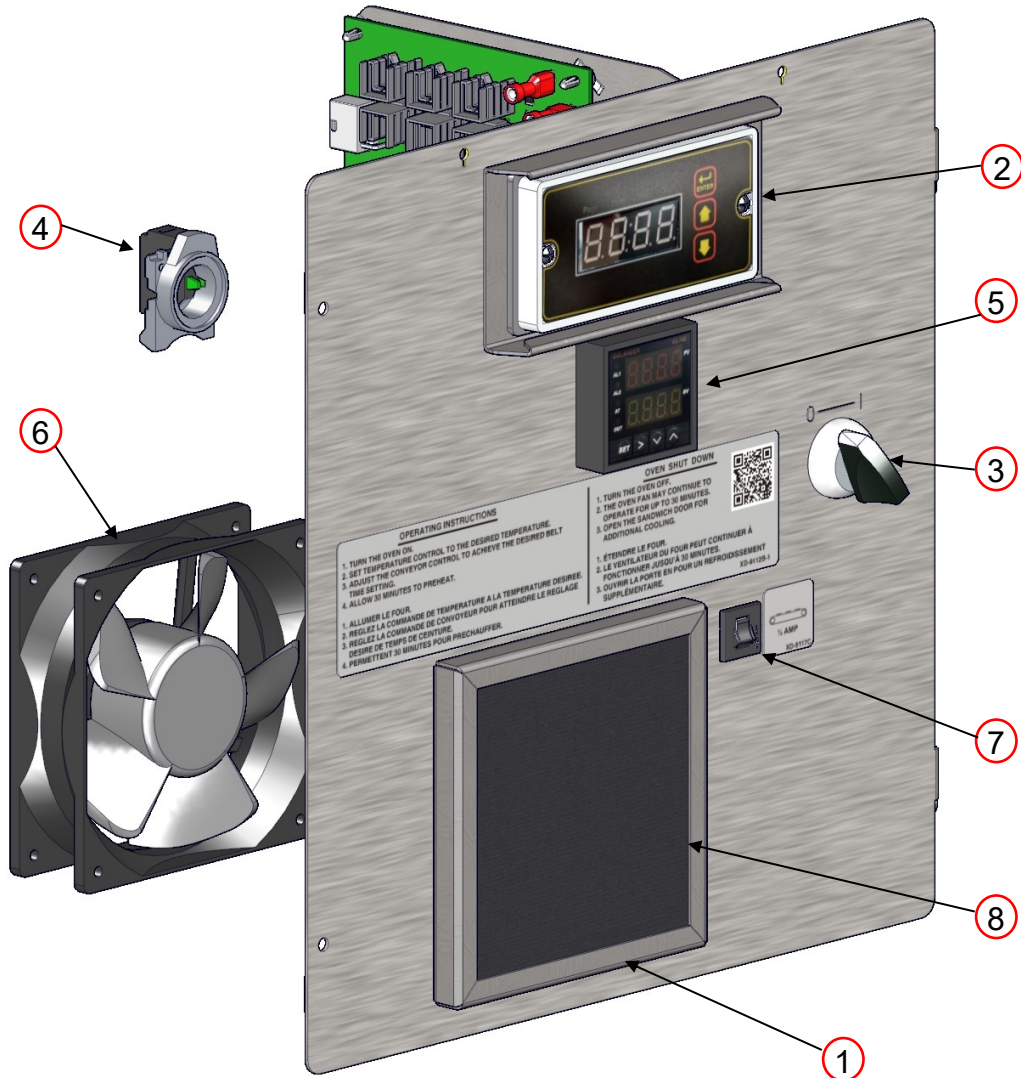

CONTROL PANEL		
ITEM	PART NUMBER	DESCRIPTION
1	SP 4520-GA	Fan Guard / Filter Repl Kit GAS
2	SP 4507-24-D	Conveyor Speed Control 24VDC
3	XP 4101	Switch Operator
4	XP 4102	Contact Block 1 Pole w/Mount
5	XP 4508	Temperature Control
6	XP 4501-GA	FPPG Fan Standard (M3)
7	XP 4515-CB	Circuit Breaker (CB)
8	XP 4520-GA	Fan Filter

Control Panel information required:

- Size of Oven
- Voltage
- Circuit Breaker amp rating
- Conveyor Belt direction

Discrete Control Package

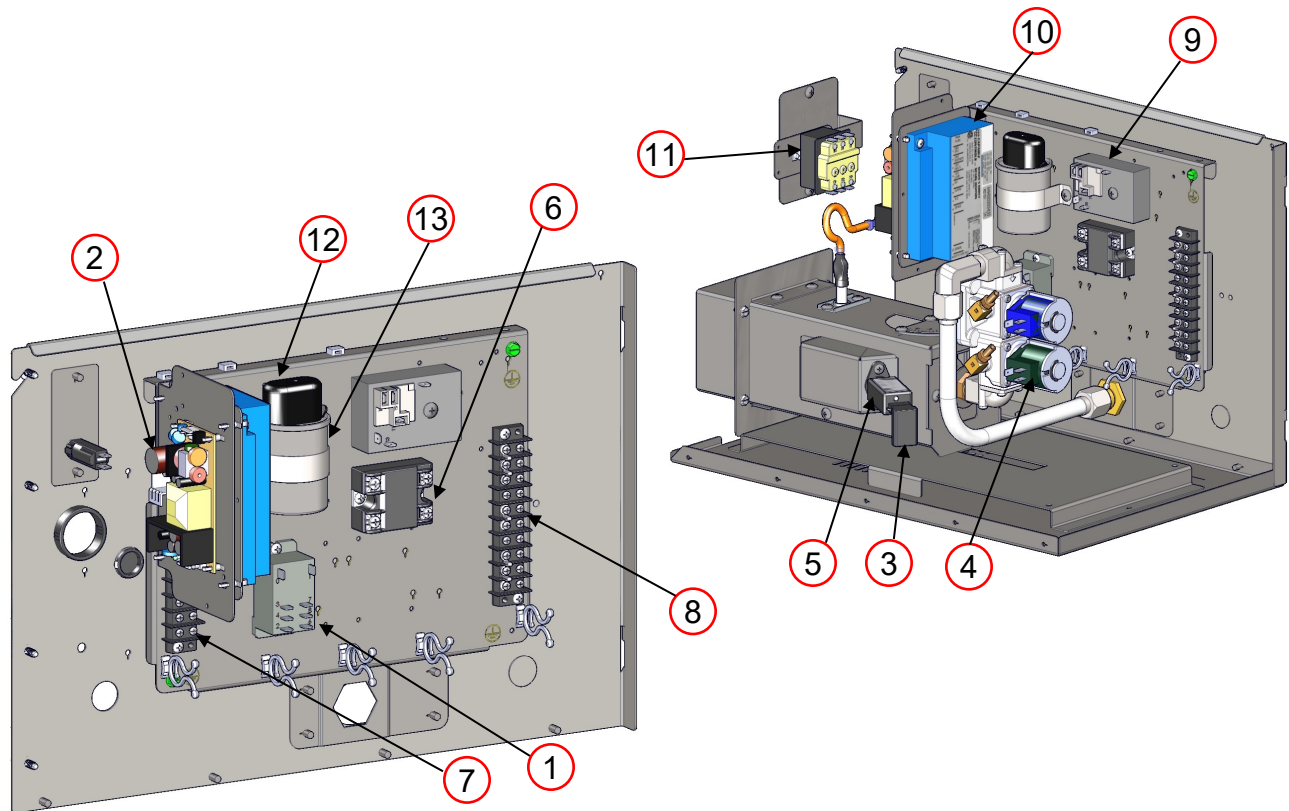

CONTROL BOX INTERIOR		
ITEM	PART NUMBER	DESCRIPTION
1	HP 2067-24VDC	Oven Fan Motor Relay (R1)
2	RP 4717	Power Supply (PS)
3	XH 4211-DC	UV Flame Sensor Wire Plug
4	XP 4207-DI-N/P	Gas Valve (V1-V2)
5	XP 4210-UV-DC	Flame Sensor (FS)
6	XP 4305-10	Relay 10A Solid State (SSR)
7	XP 4701-04	Terminal Strip 4 Place (TS)
8	XP 4701-10	Terminal Strip 10 Place (TS)
9	XP 4704-120 VOLT	Cool Down Timer 120 Volt R1
10	XP 4705-DI-120	Ignition Control 120 VAC (IC)
11	XP 4723A	High Temp Limit Switch (S3)
12	XP 5012	Capacitor Boot
13	XP 5014-30	Capacitor Baldor 3/4 HP 30uF (CAP)

Control Panel information required:

- Size of Oven
- Voltage

Discrete Control Package

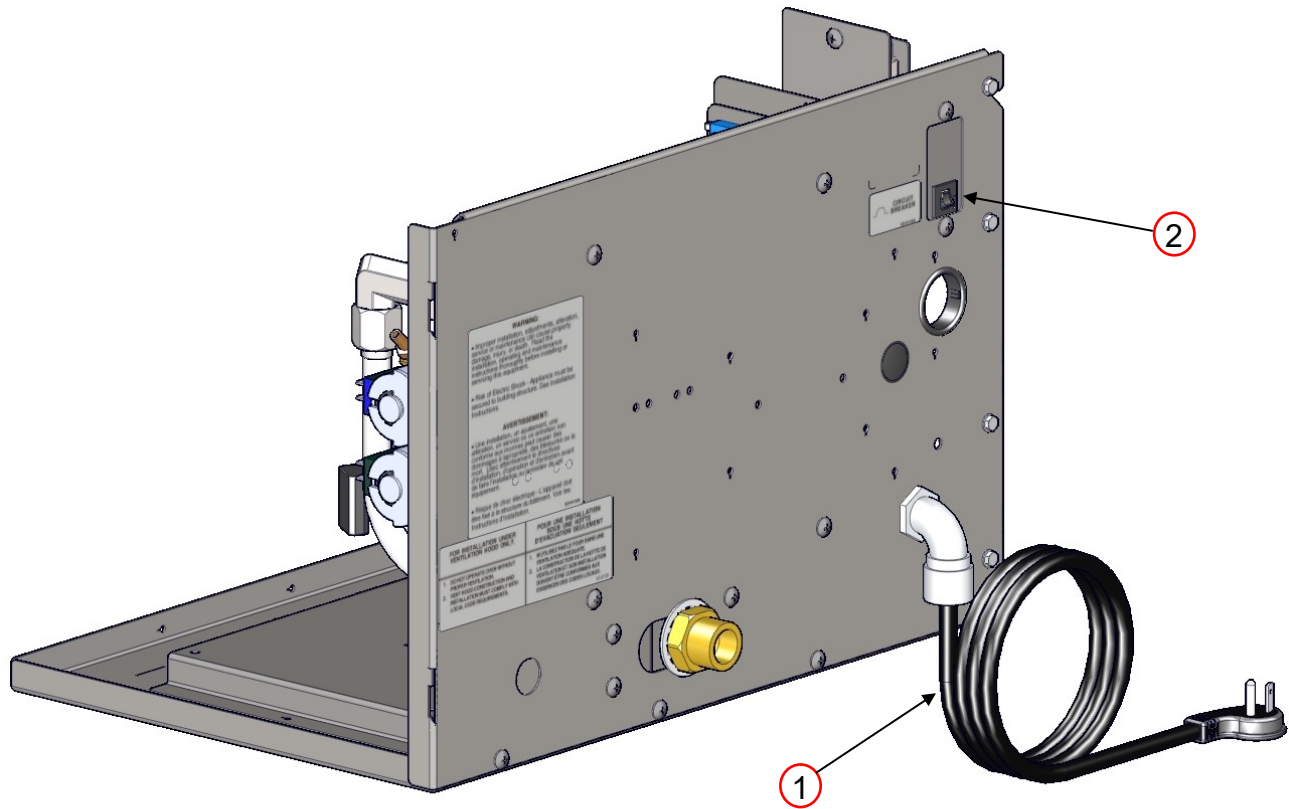

CONTROL BOX REAR		
ITEM	PART NUMBER	DESCRIPTION
1	XA 9301-S	Power Cord Assembly
2	XP 4515-CB-15A	15 Amp Circuit Breaker (CB)

Control Panel information required:

- Size of Oven
- Voltage
- Circuit Breaker amp rating

**Discrete Control Package
Operating Position (shown with lid removed)**

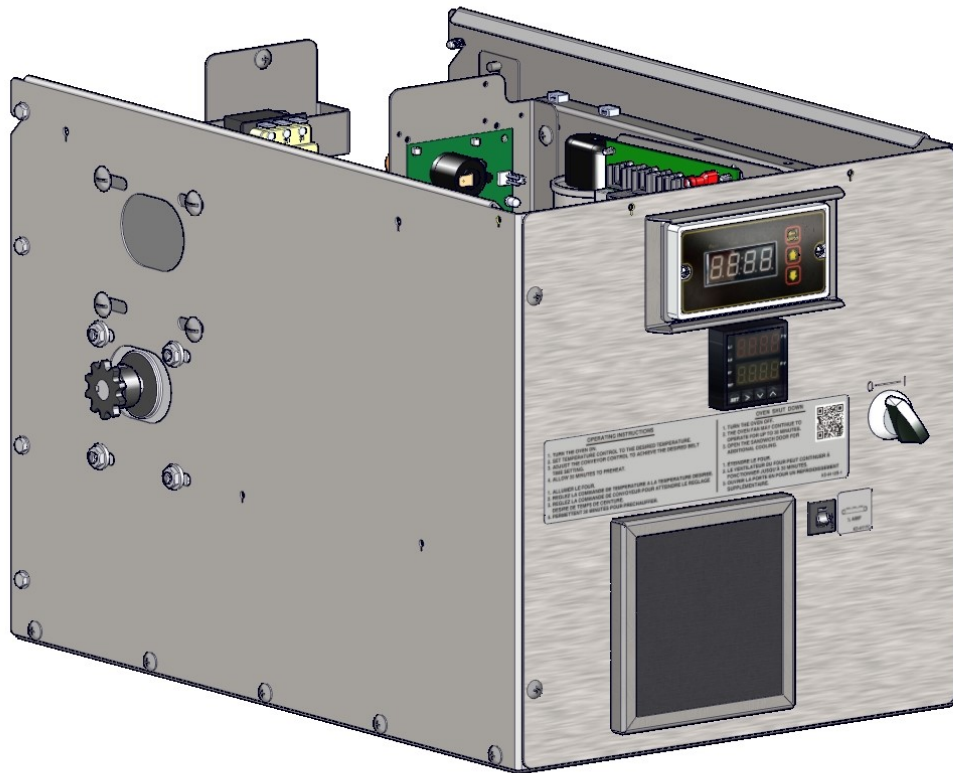

Discrete Control Package
Service Position

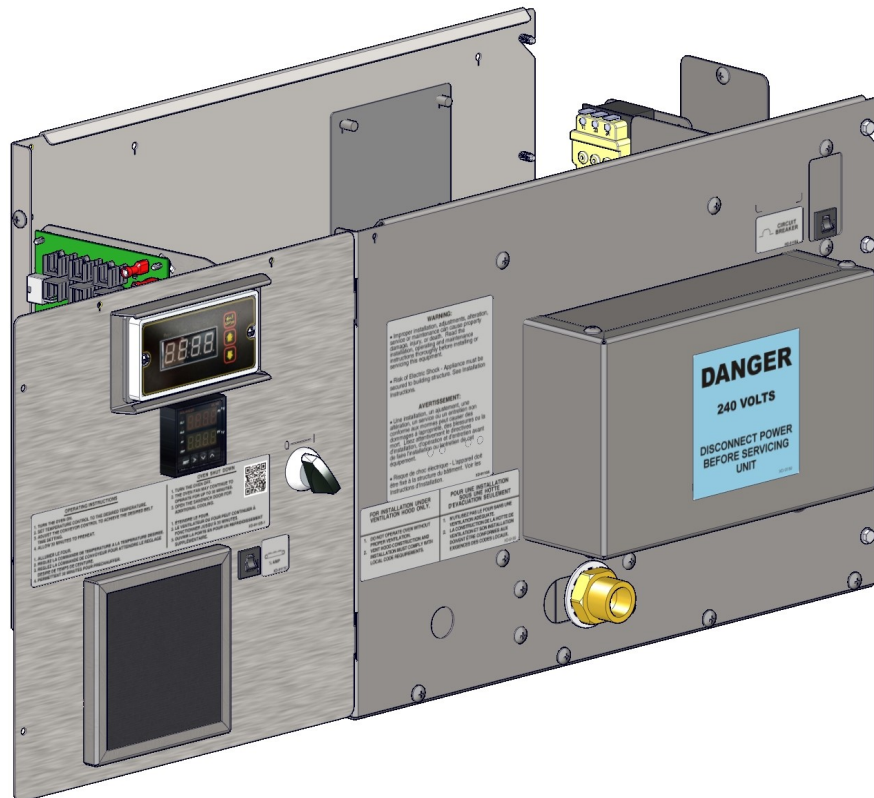
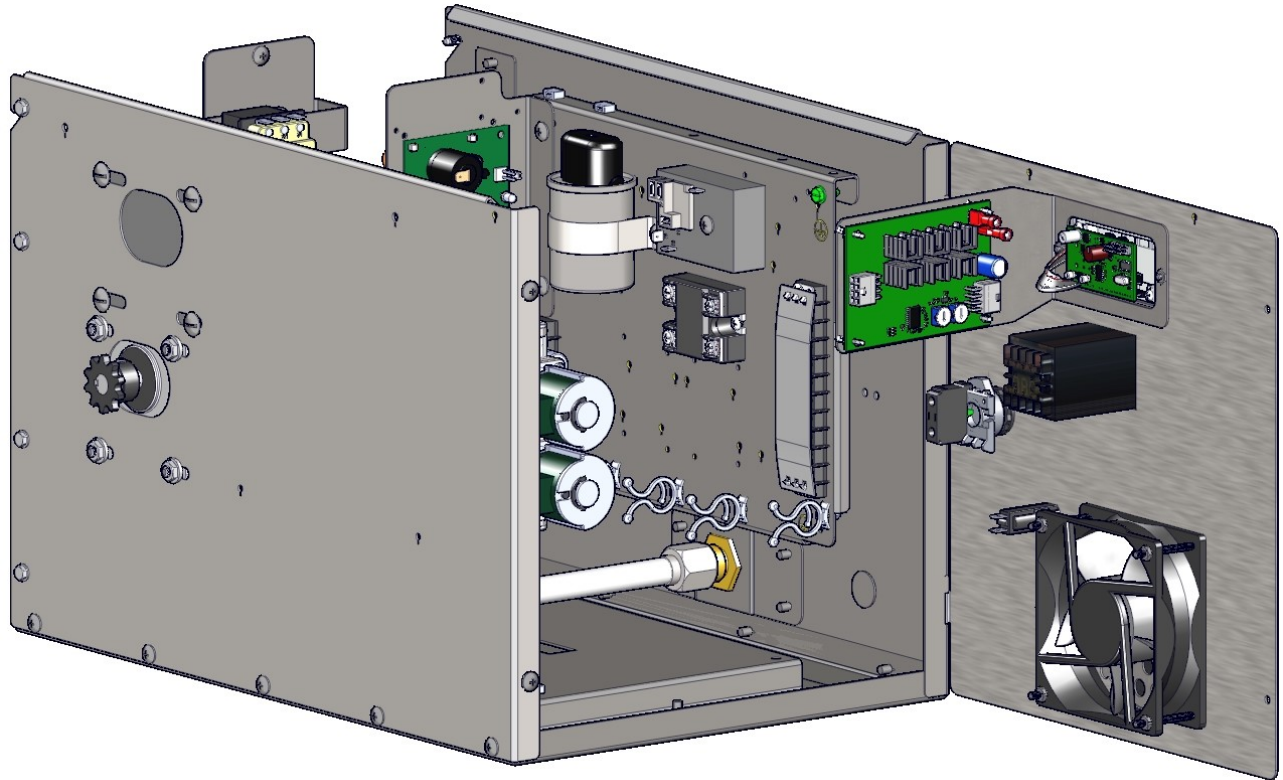

Discrete Control Package

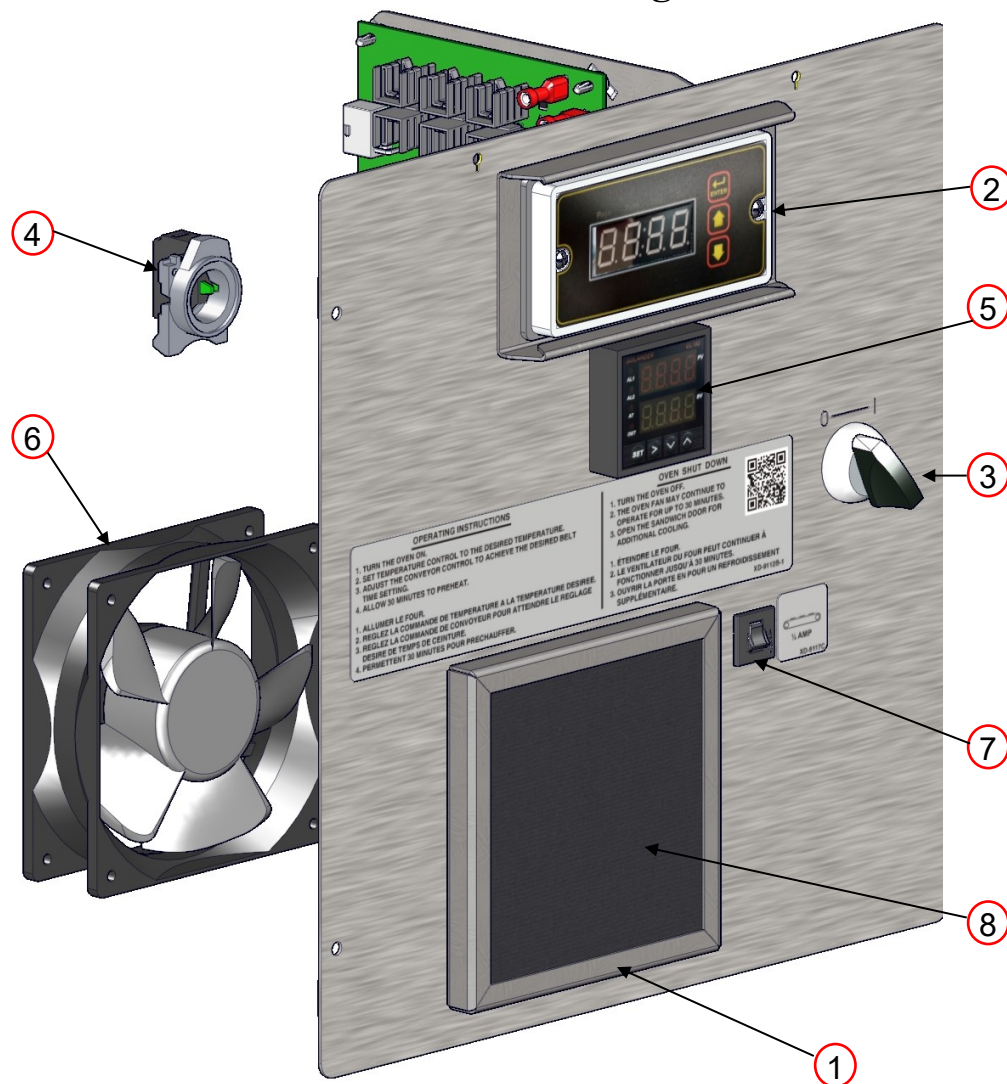

CONTROL PANEL		
ITEM	PART NUMBER	DESCRIPTION
1	SP 4520-GA	Fan Guard / Filter Repl Kit GAS
2	SP 4507-24-D	Conveyor Speed Control 24VDC
3	XP 4101	Switch Operator
4	XP 4102	Contact Block 1 Pole w/Mount
5	XP 4508	Temperature Control
6	XP 4501-GA	FPPG Fan Standard (M3)
7	XP 4515-CB	Circuit Breaker (CB)
8	XP 4520-GA	Fan Filter

Control Panel information required:

- Size of Oven
- Voltage
- Circuit Breaker amp rating
- Conveyor Belt direction

Discrete Control Package

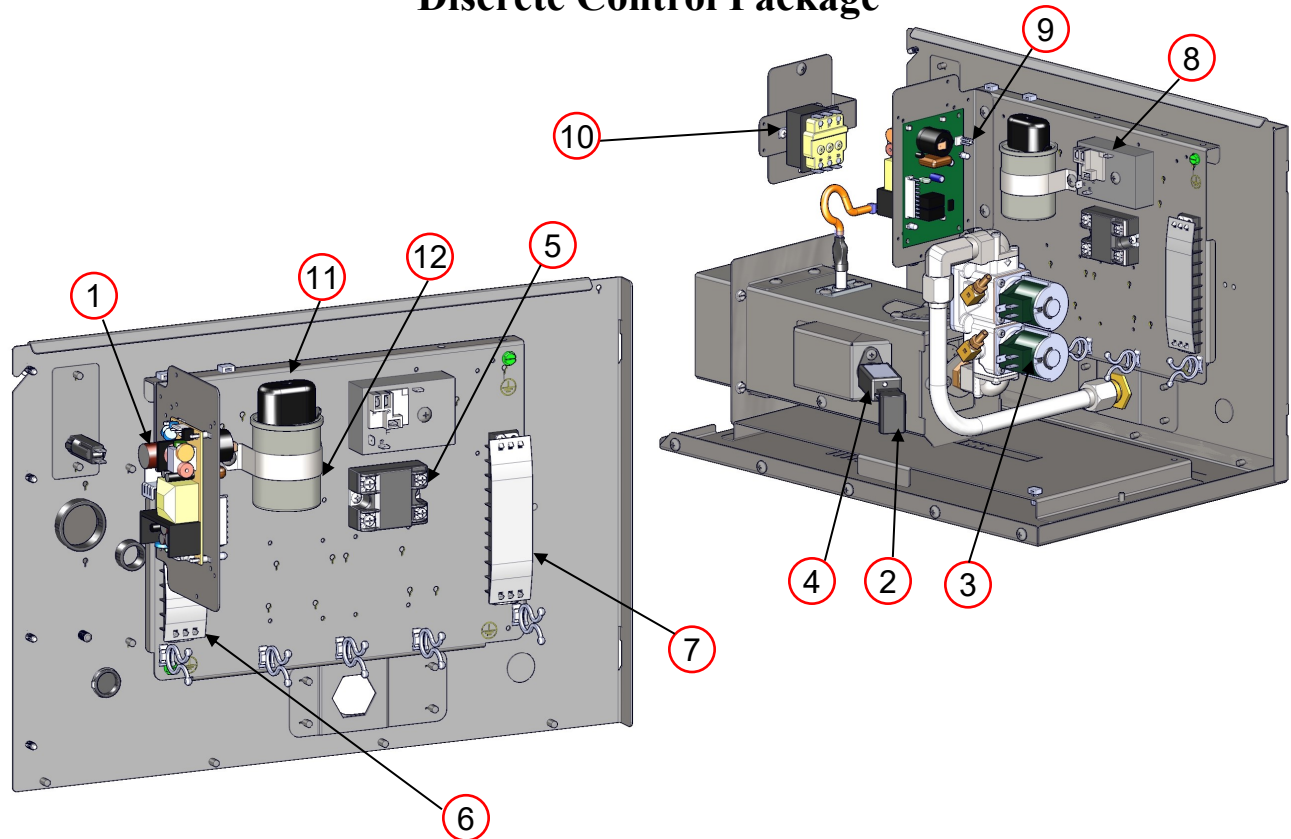

CONTROL BOX INTERIOR		
ITEM	PART NUMBER	DESCRIPTION
1	RP 4717	Power Supply (PS)
2	XH 4211-DC	UV Flame Sensor Wire Plug
3	XP 4207-DI-N/P	Gas Valve (V1-V2)
4	XP 4210-UV-DC	Flame Sensor (FS)
5	XP 4305-10	Relay 10A Solid State (SSR)
6	XP 4701-04	Terminal Strip 4 Place (TS)
7	XP 4701-10	Terminal Strip 10 Place (TS)
8	XP 4704-120 VOLT	Cool Down Timer 120 Volt R1
9	XP 4705-DI-24	Ignition Control 24 VAC (IC)
10	XP 4723A	High Temp Limit Switch (S3)
11	XP 5012	Capacitor Boot
12	XP 5014-30	Capacitor Baldor 3/4 HP 30uF (CAP)

Control Panel information required:

- Size of Oven
- Voltage

Discrete Control Package

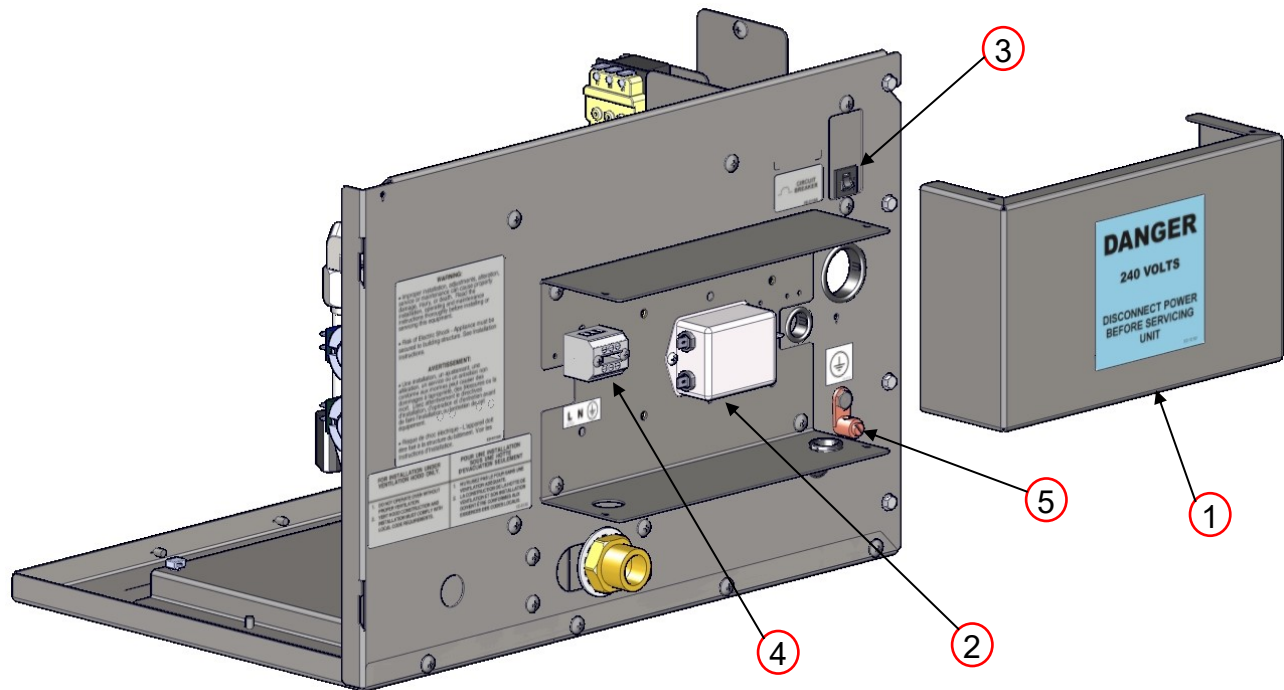

CONTROL BOX REAR		
ITEM	PART NUMBER	DESCRIPTION
1	XM 9303	Power Inlet Box Cover
2	XP 4320	EMI Power Filter FLT1
3	XP 4515-CB-7A	7 Amp Circuit Breaker CB
4	XP 4702-03-W	Terminal Strip 3 Pole TS
5	XP 4707	Ground Lug Copper World

Control Panel information required:

- Size of Oven
- Voltage
- Circuit Breaker amp rating

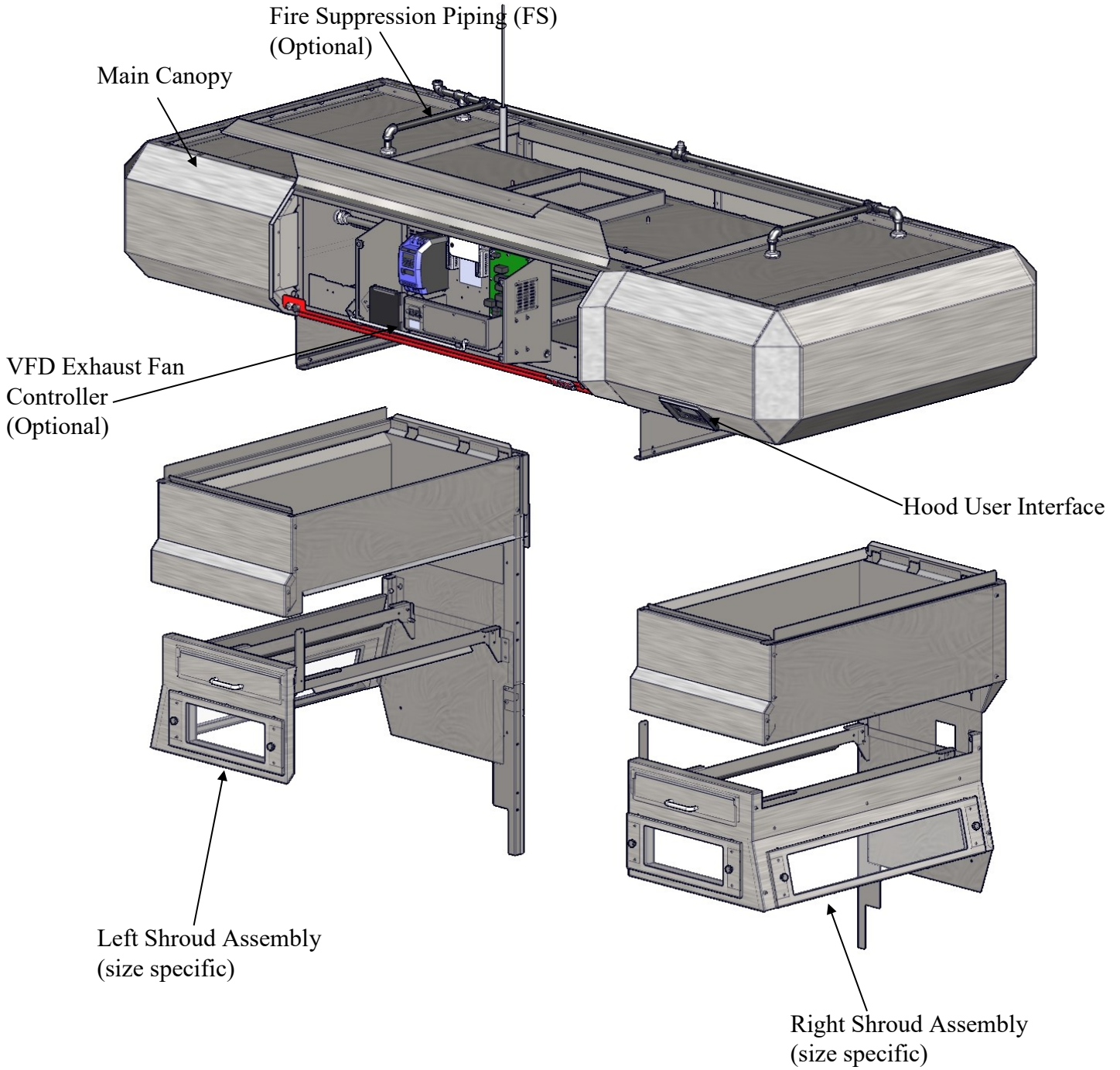

VFD Control Box

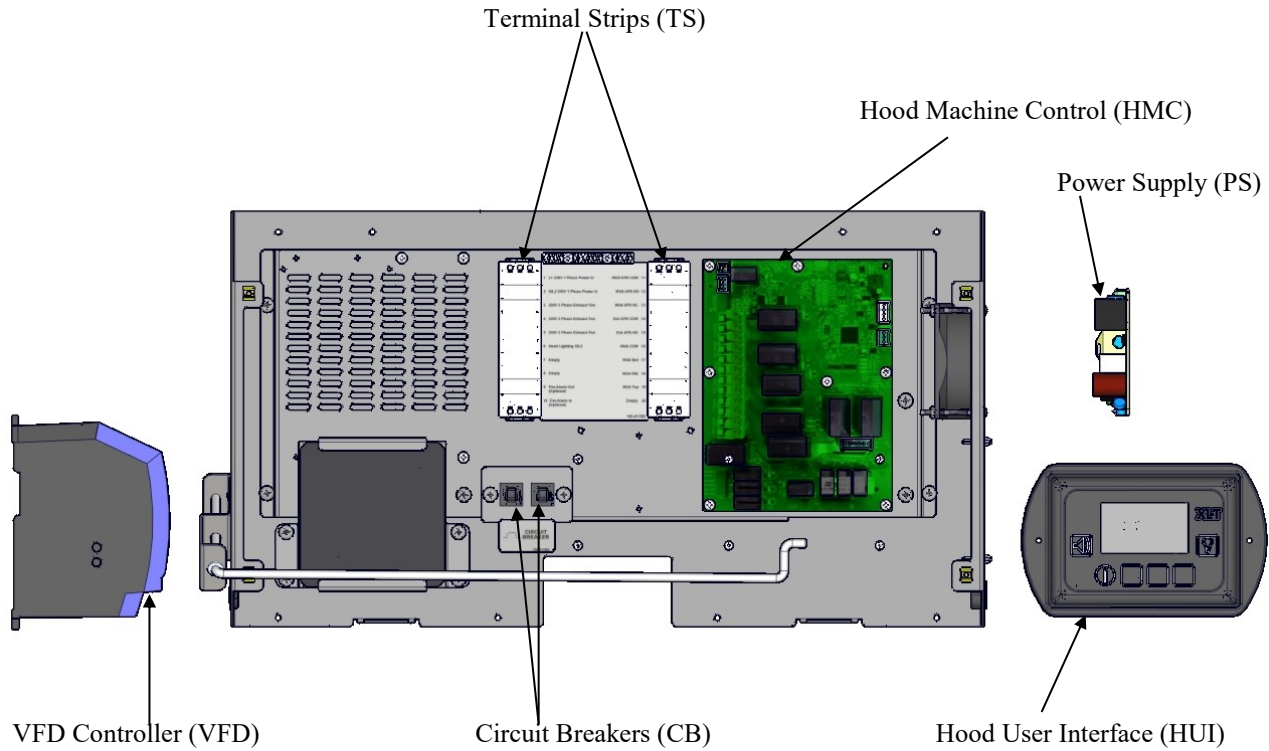

VFD Control Box (Cover removed)

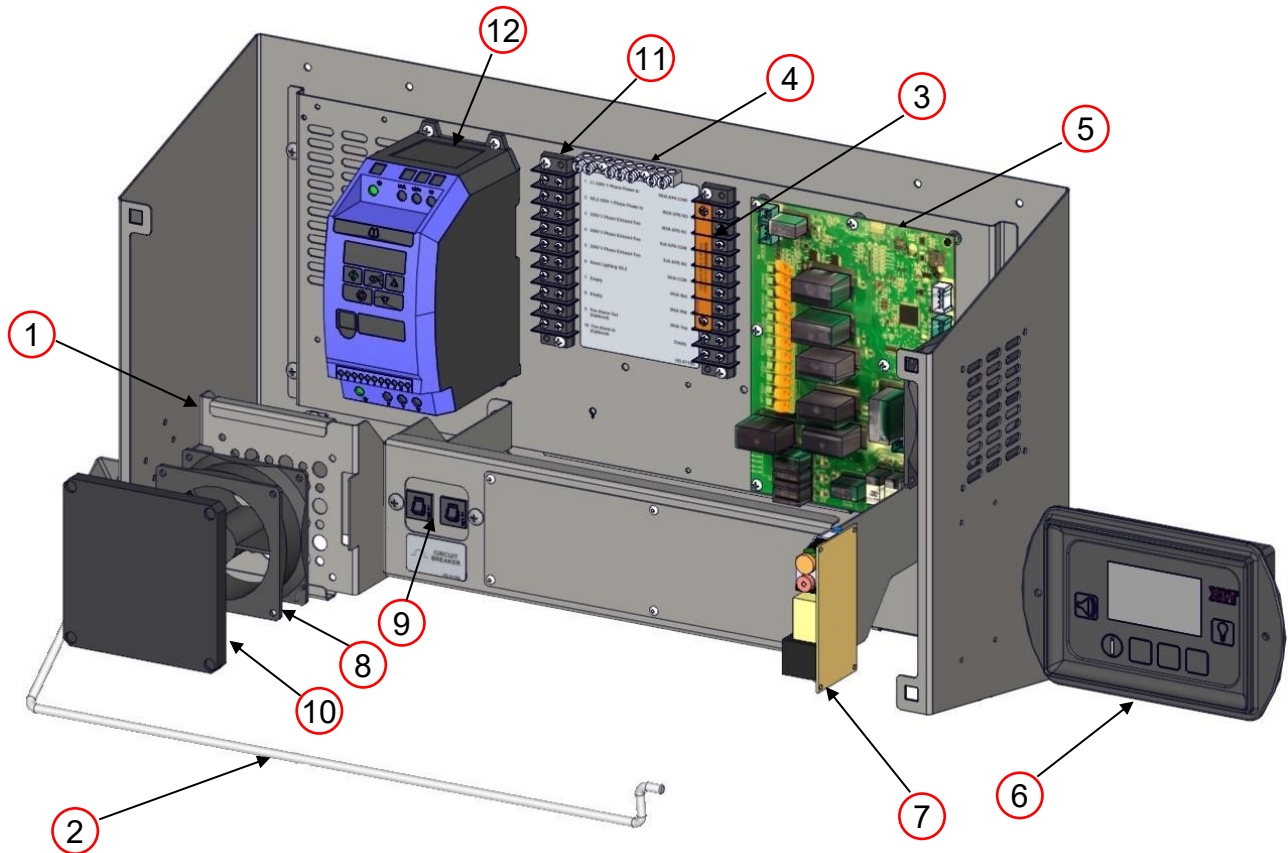

VFD W/ FIRE SUPPRESSION		
ITEM	PART NUMBER	DESCRIPTION
1	02-1-4004	Fan Mount
2	96-0-4014	Prop Rod
3	HD-9130	No Voltage Label
4	HP-2058	Ground Bar 7 POS
5	HP-2070-MC	Hood Machine Control HMC
6	HP-2071-UI	Hood User Interface HUI
7	RP-4717	Power Supply PS
8	XP-4501-EL	FPPG Fan EL M2
9	XP-4514-CB-10A	Circuit Breaker 10.0 Amp
10	XP-4520-GA	Fan Filter
11	XP-4701-10	Terminal Strip 10 Place TS
12	XP-4718-4.3	VFD Invertek Optidrive E3

This page intentionally left blank.

This page is intentionally left blank.

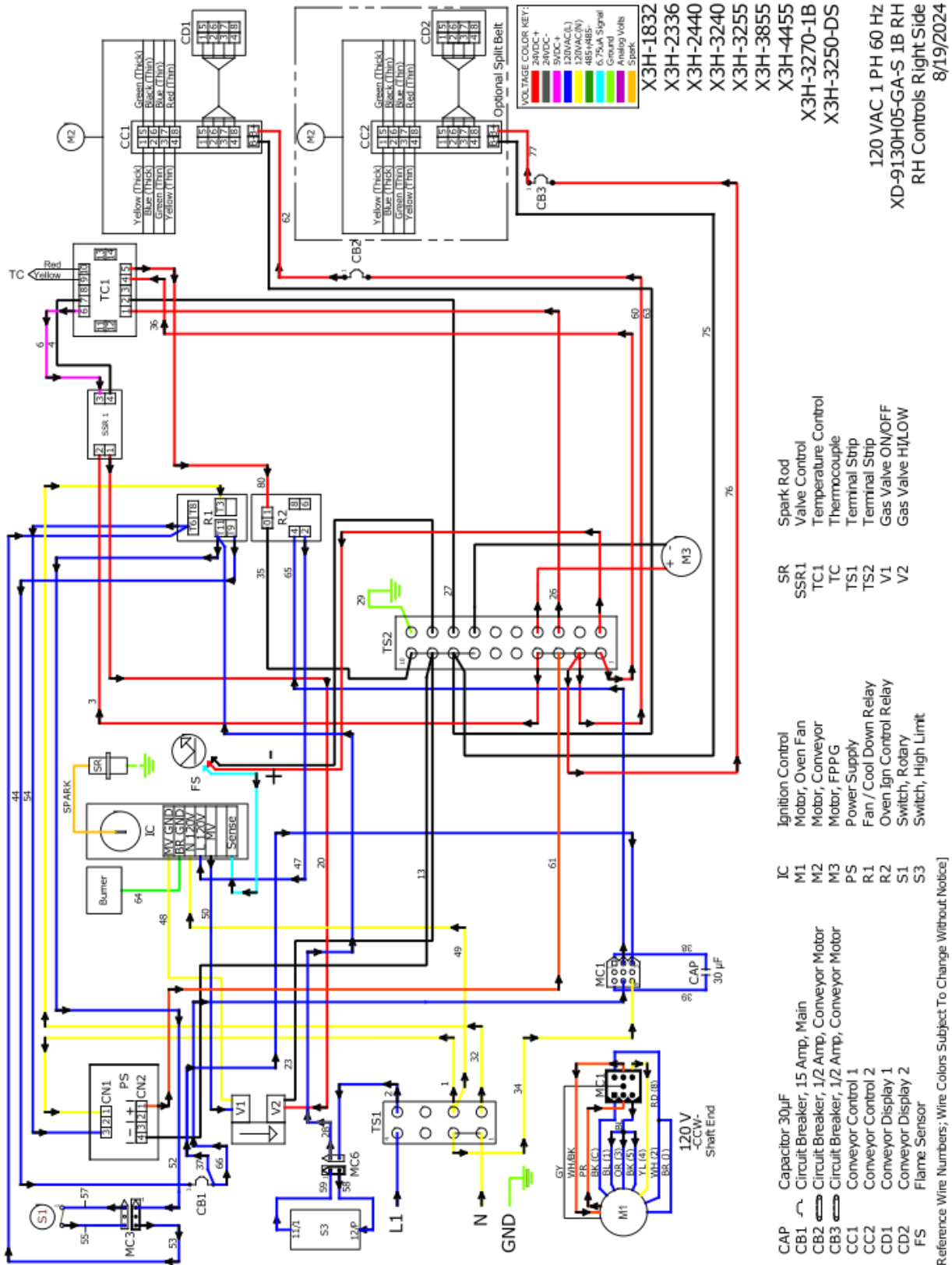

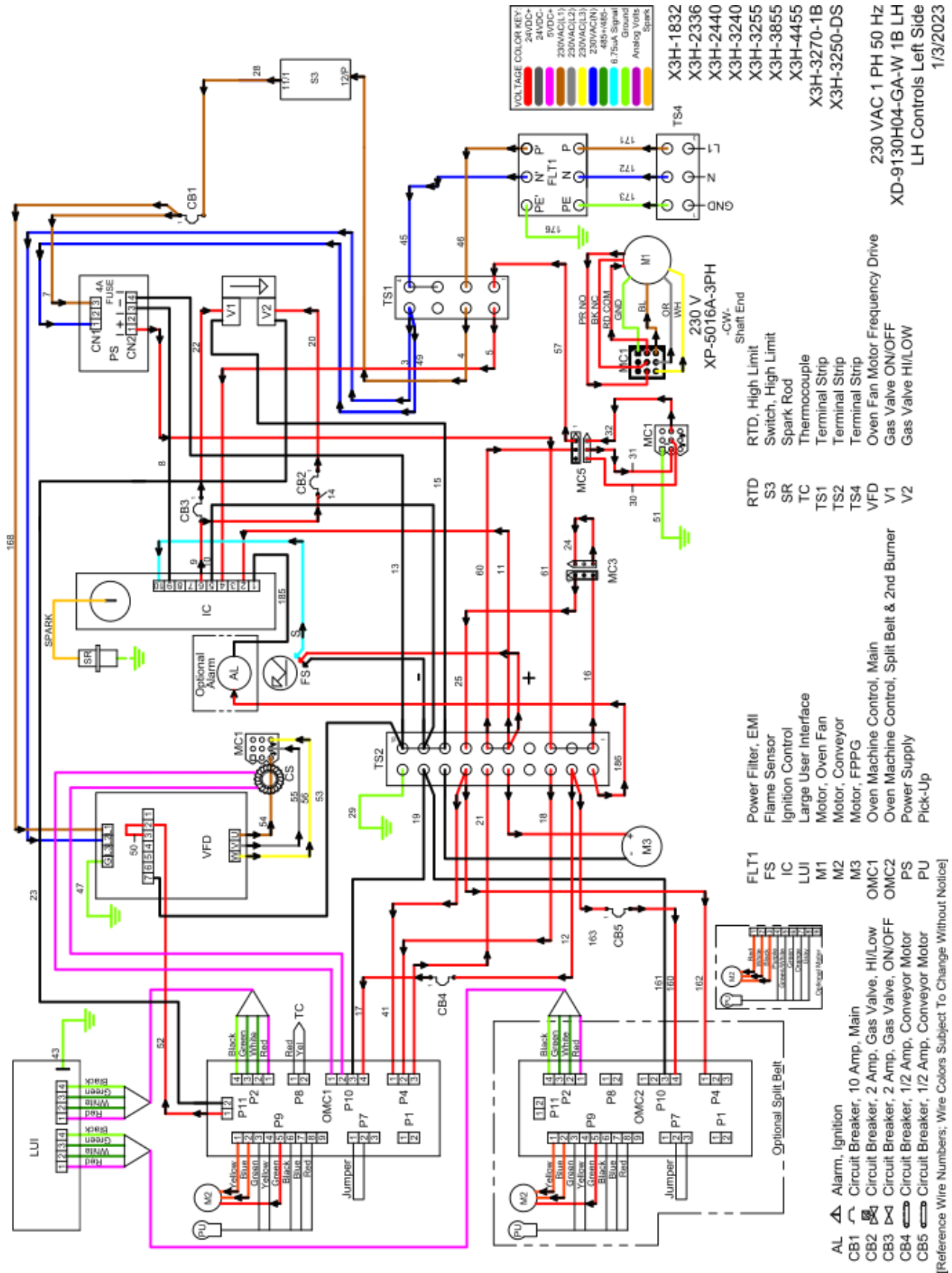

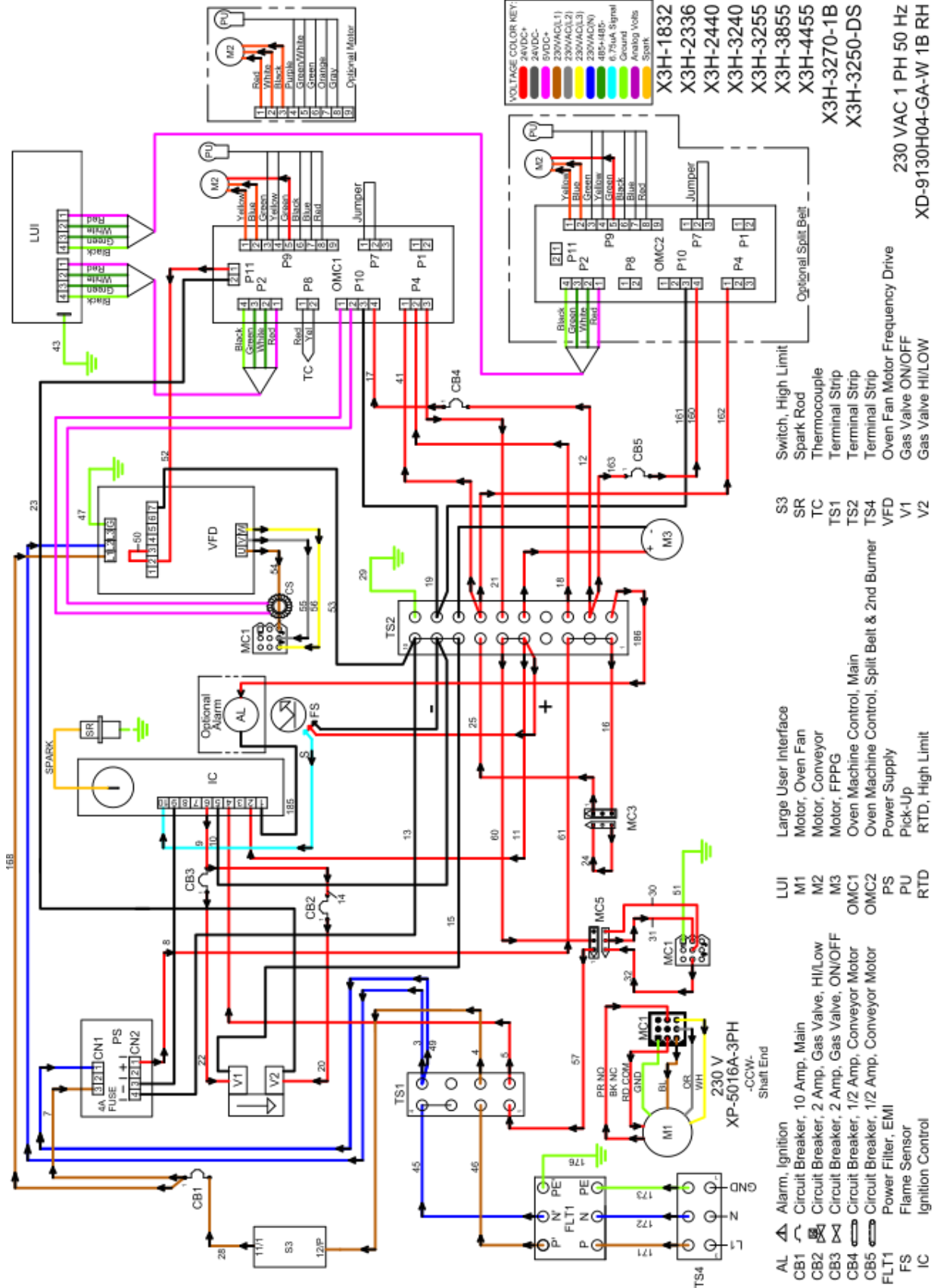

This page is intentionally left blank.

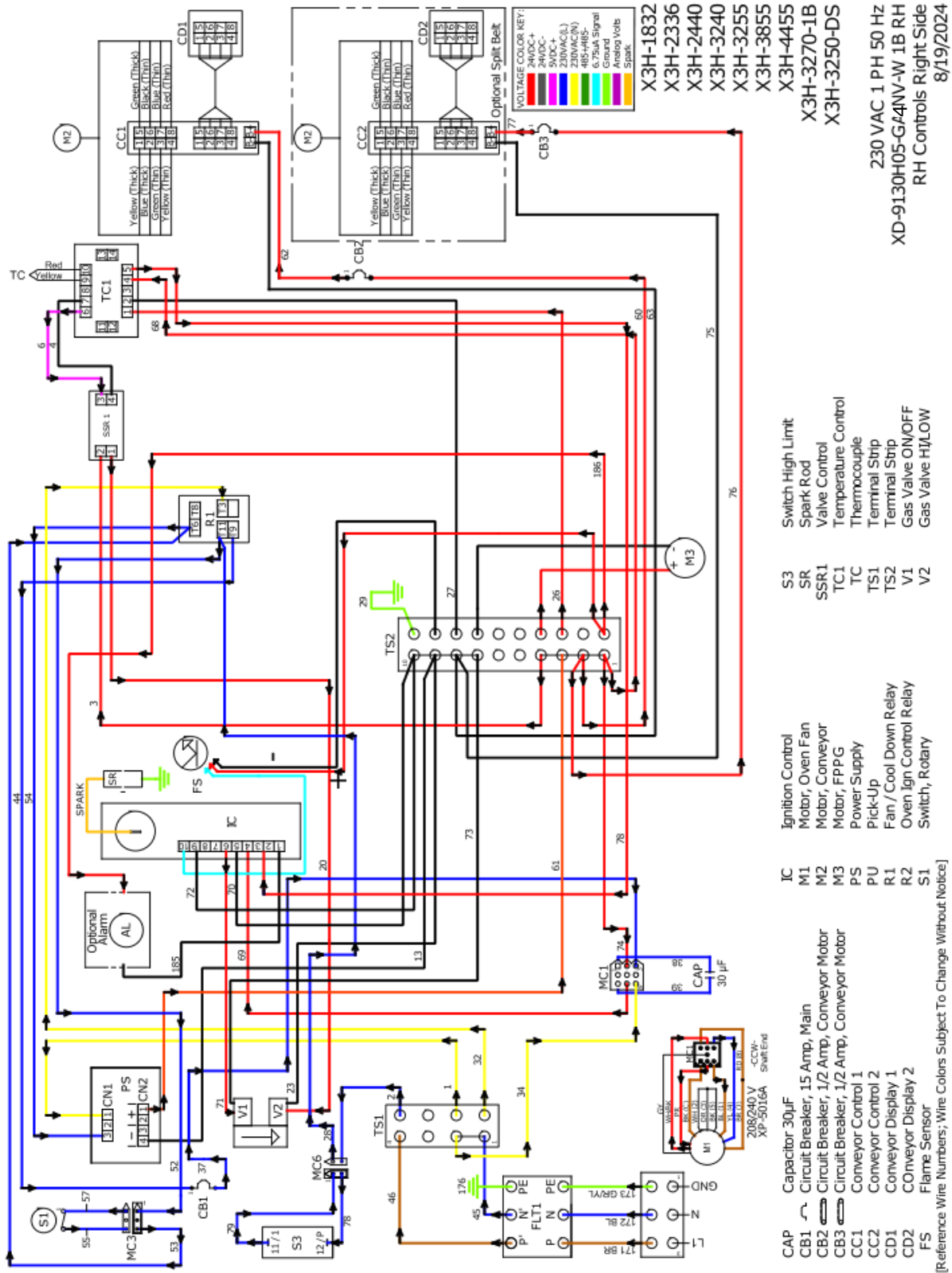

100 OVEN SCHEMATIC - AUSTRALIA VFD 1 BOX 230 VAC LH

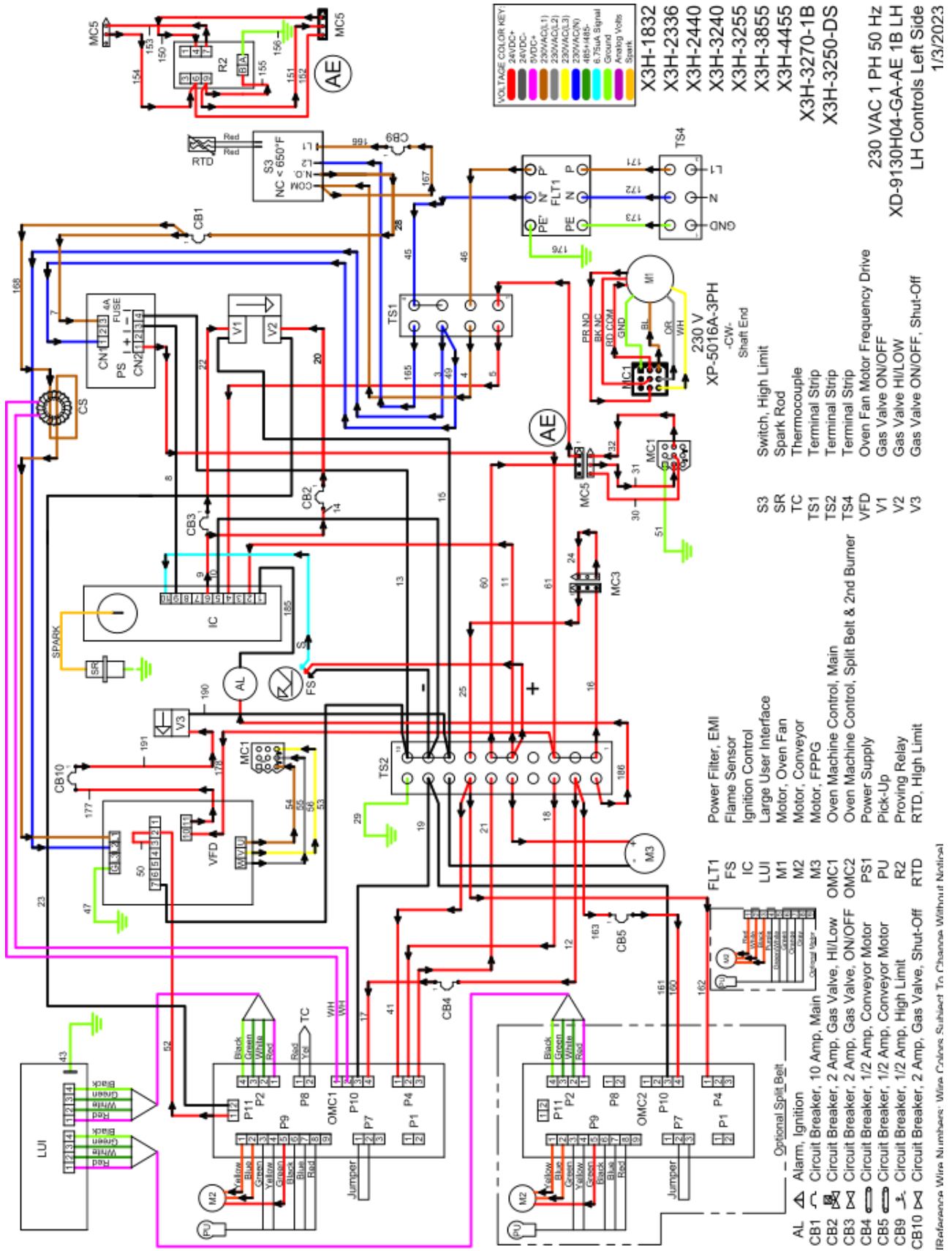

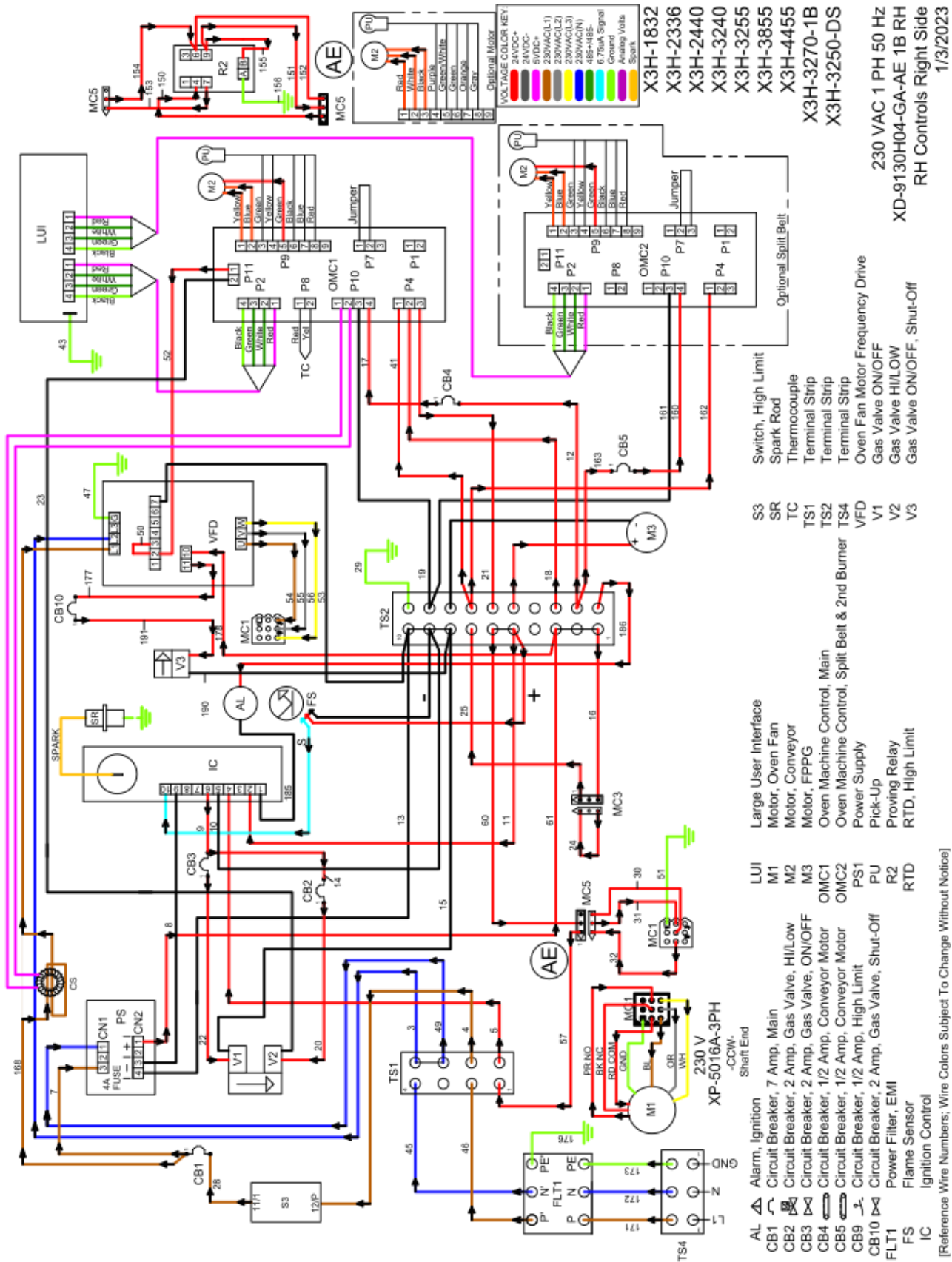

This page is intentionally left blank.

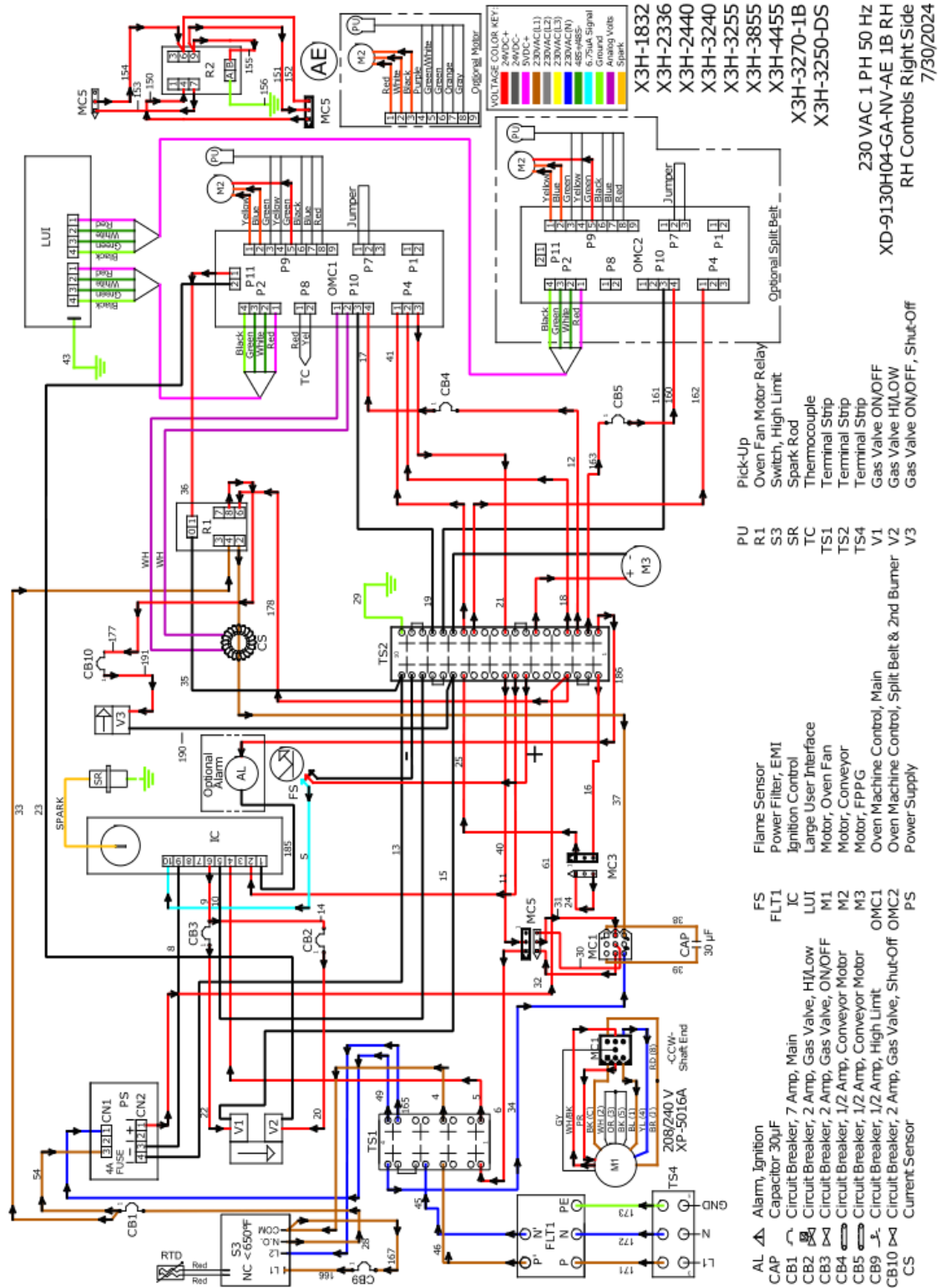

230 VAC 1 PH 50 HZ
 XD-9130H04-GA-NV-AE 1B RH
 RH Controls Right Side
 7/30/2024

104 OVEN SCHEMATIC - STANDARD 2 BOX 120 VAC RHC LEFT SIDE

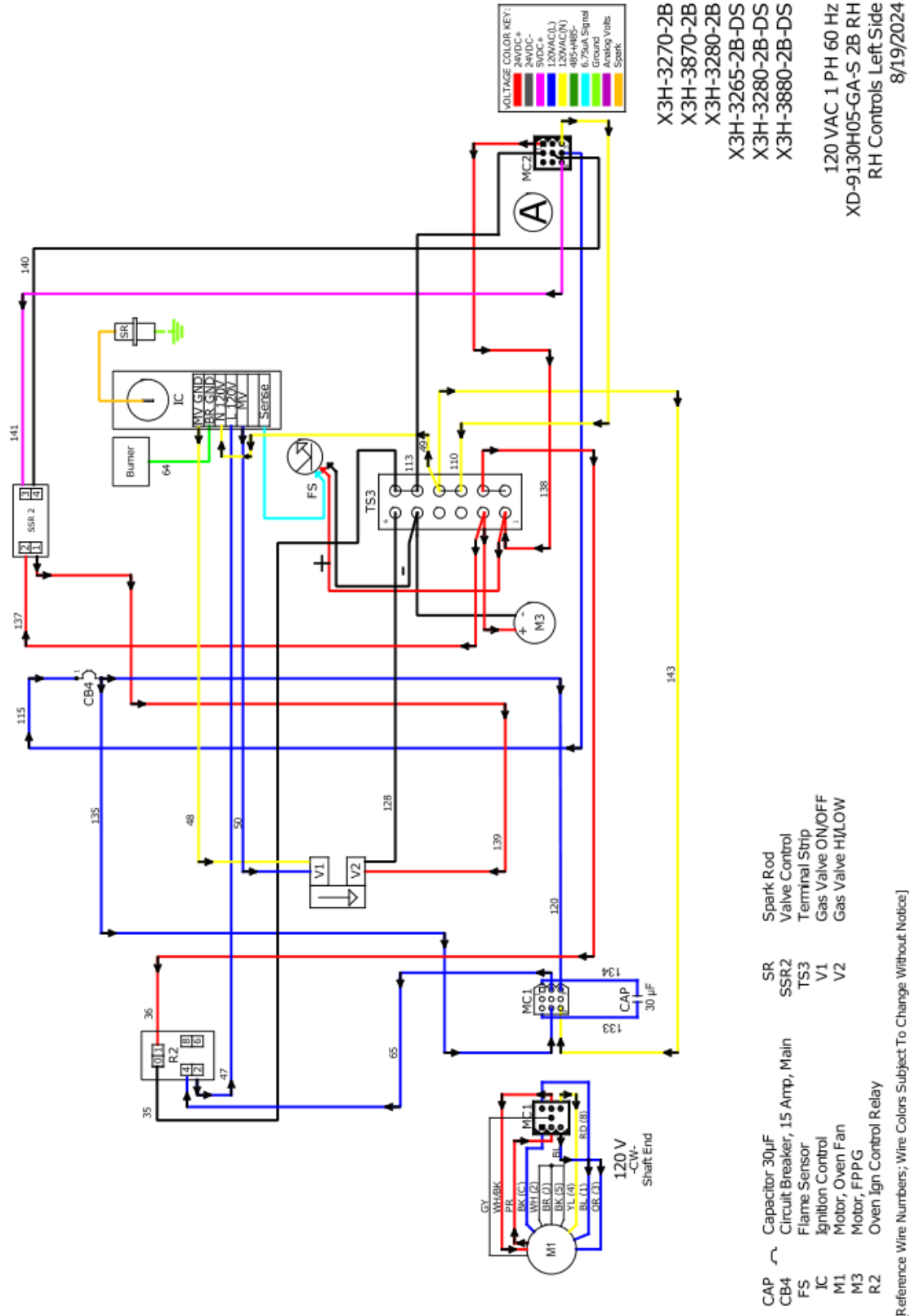

OVEN SCHEMATIC - STANDARD 2 BOX 120 VAC RHC RIGHT SIDE 105

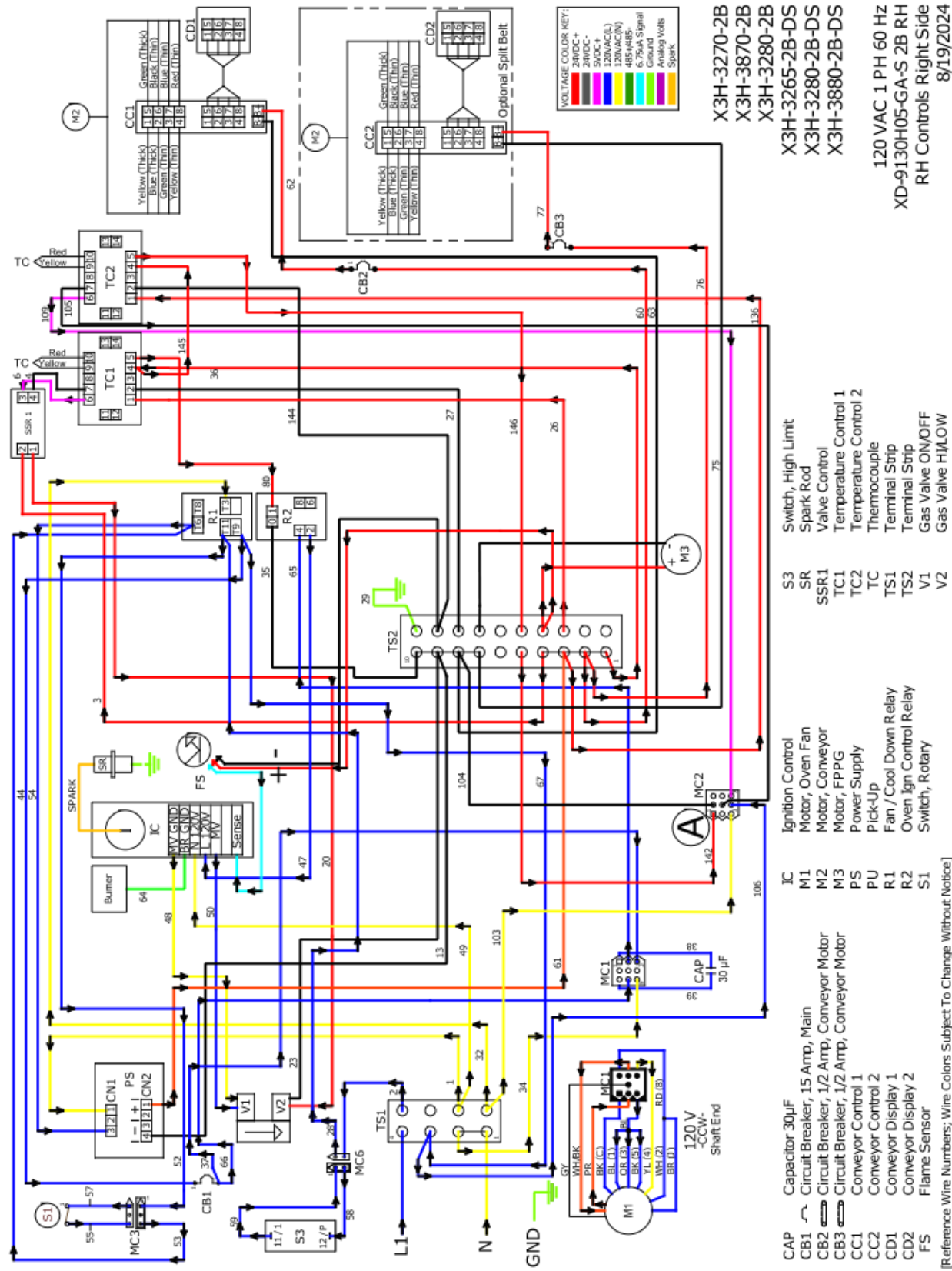

106 OVEN SCHEMATIC - WORLD 2 BOX 230 VAC LHC LEFT SIDE

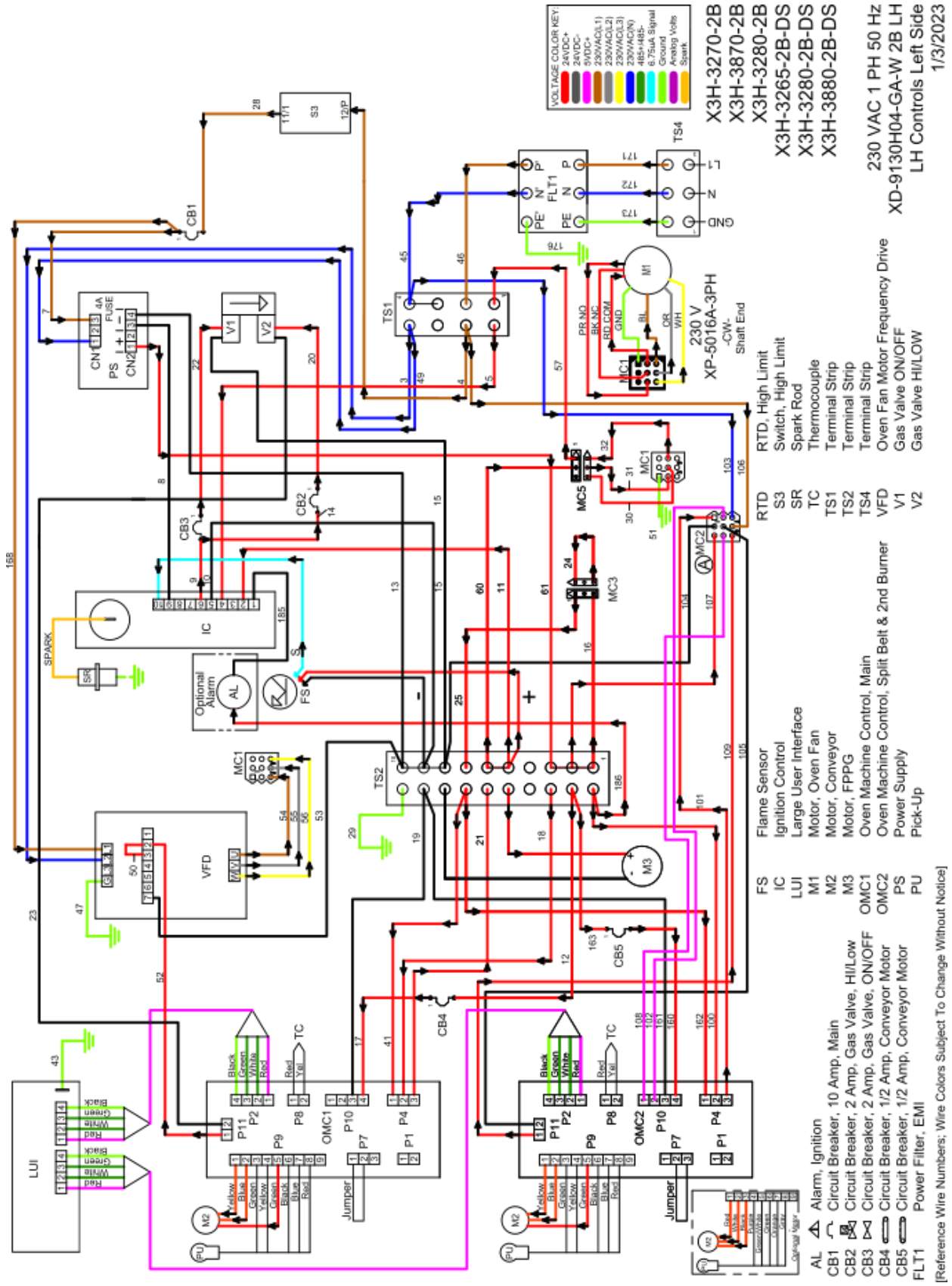

[Reference Wire Numbers; Wire Colors Subject To Change Without Notice]

OVEN SCHEMATIC - WORLD 2 BOX 230 VAC LHC RIGHT SIDE 107

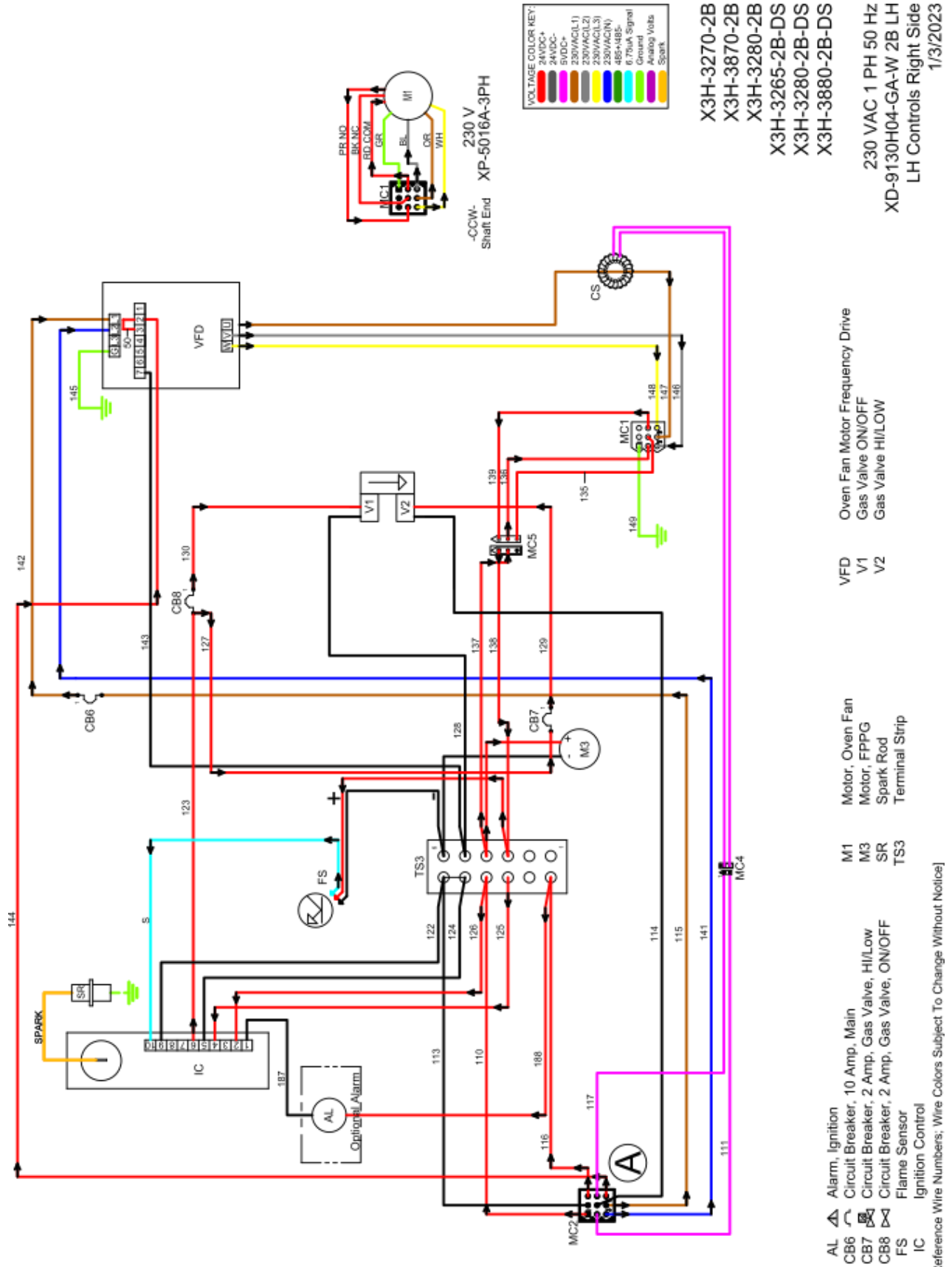

- X3H-3270-2B
- X3H-3870-2B
- X3H-3280-2B
- X3H-3265-2B-DS
- X3H-3280-2B-DS
- X3H-3880-2B-DS

230 VAC 1 PH 50 Hz
XD-9130H04-GA-W 2B LH
LH Controls Right Side
1/3/2023

108 OVEN SCHEMATIC - WORLD 2 BOX 230 VAC RHC LEFT SIDE

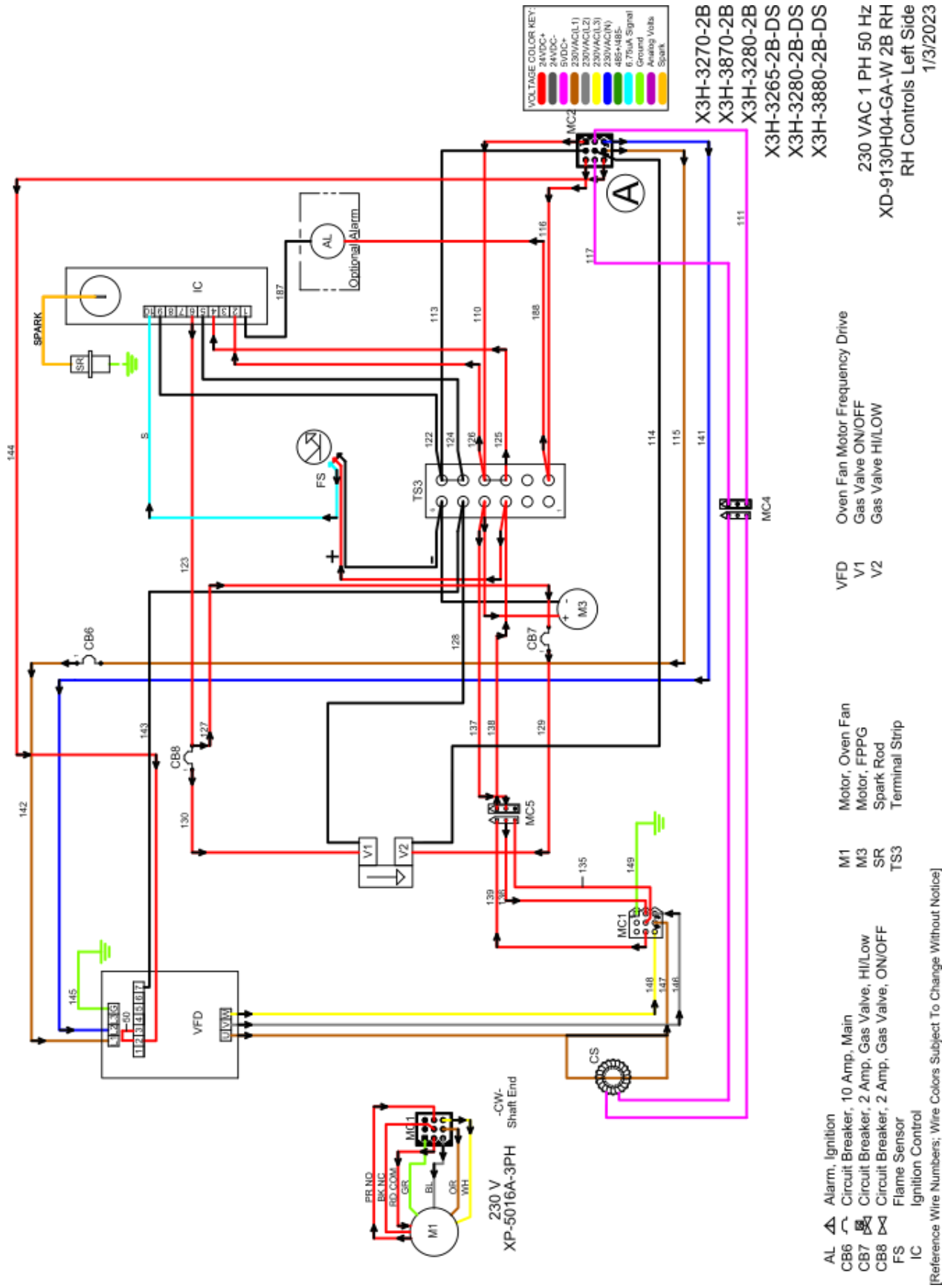

OVEN SCHEMATIC - WORLD 2 BOX 230 VAC RHC RIGHT SIDE 109

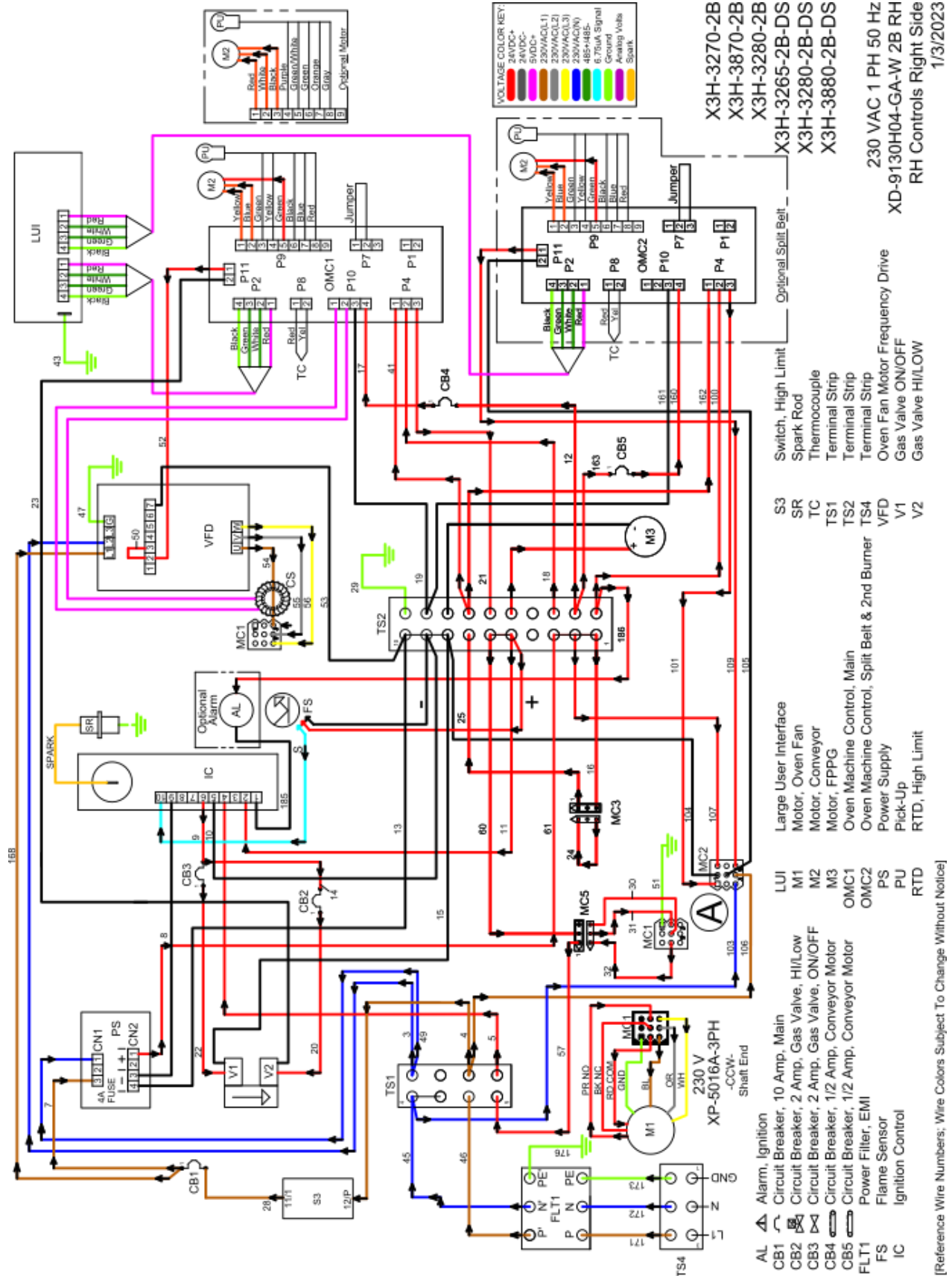

110 OVEN SCHEMATIC - WORLD NON VFD 2 BOX 230 VAC RHC LEFT SIDE

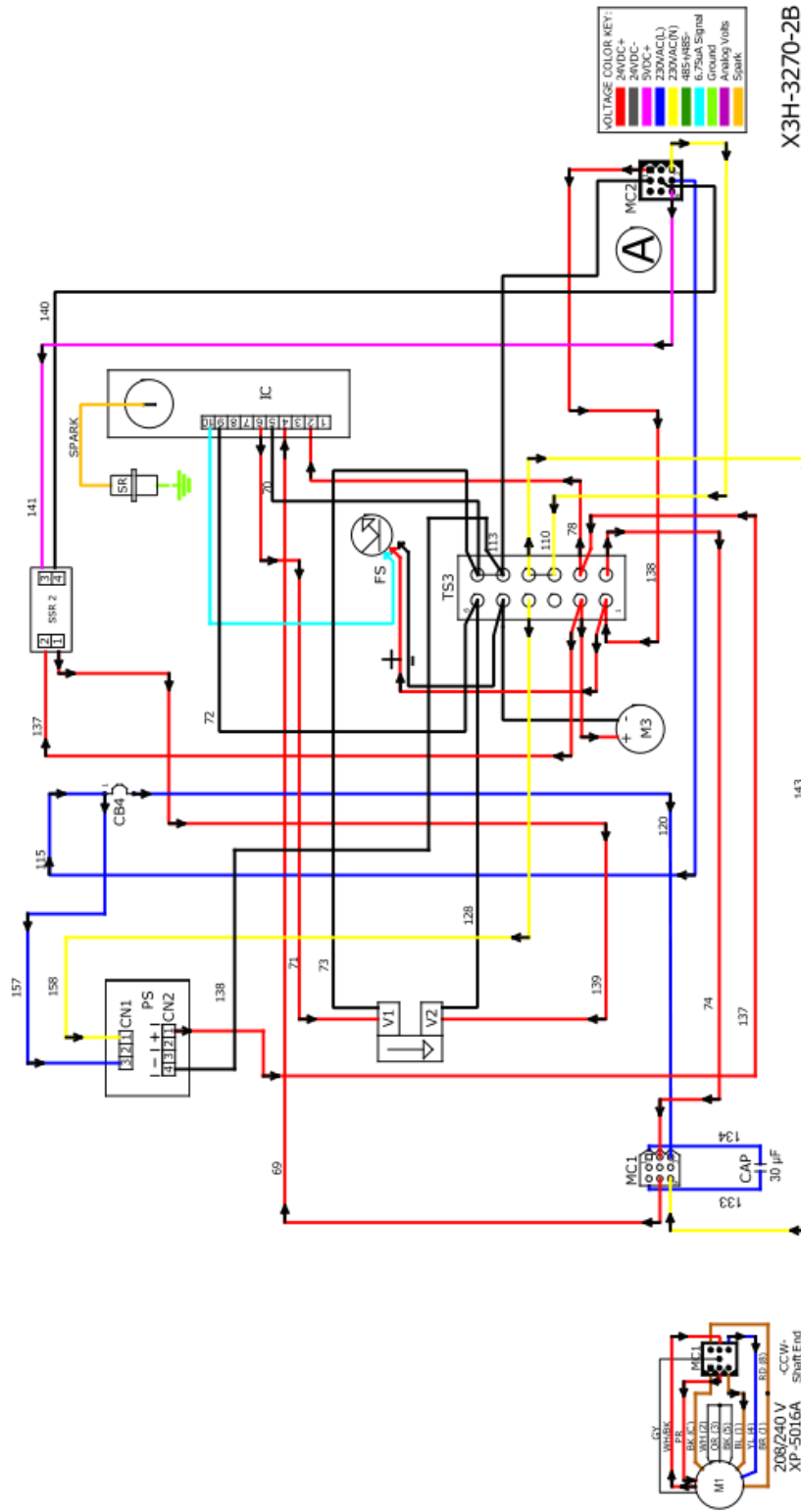

- X3H-3270-2B
- X3H-3870-2B
- X3H-3280-2B
- X3H-3265-2B-DS
- X3H-3280-2B-DS
- X3H-3880-2B-DS

230 VAC 1 PH 50 Hz
 XD-9130H05-GA-NV-W 2B RH
 RH Controls Left Side
 8/15/2024

[Reference Wire Numbers; Wire Colors Subject To Change Without Notice]

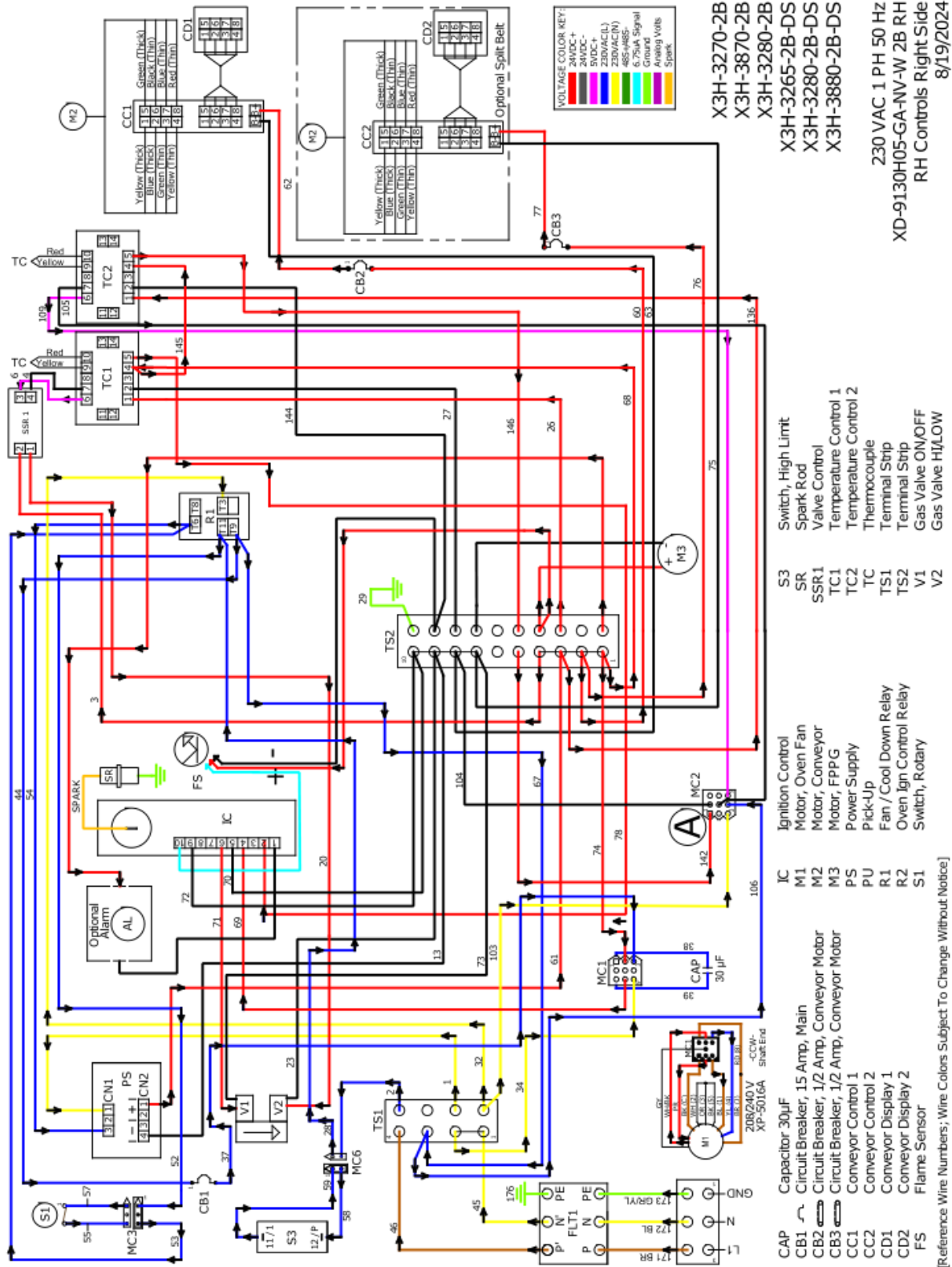

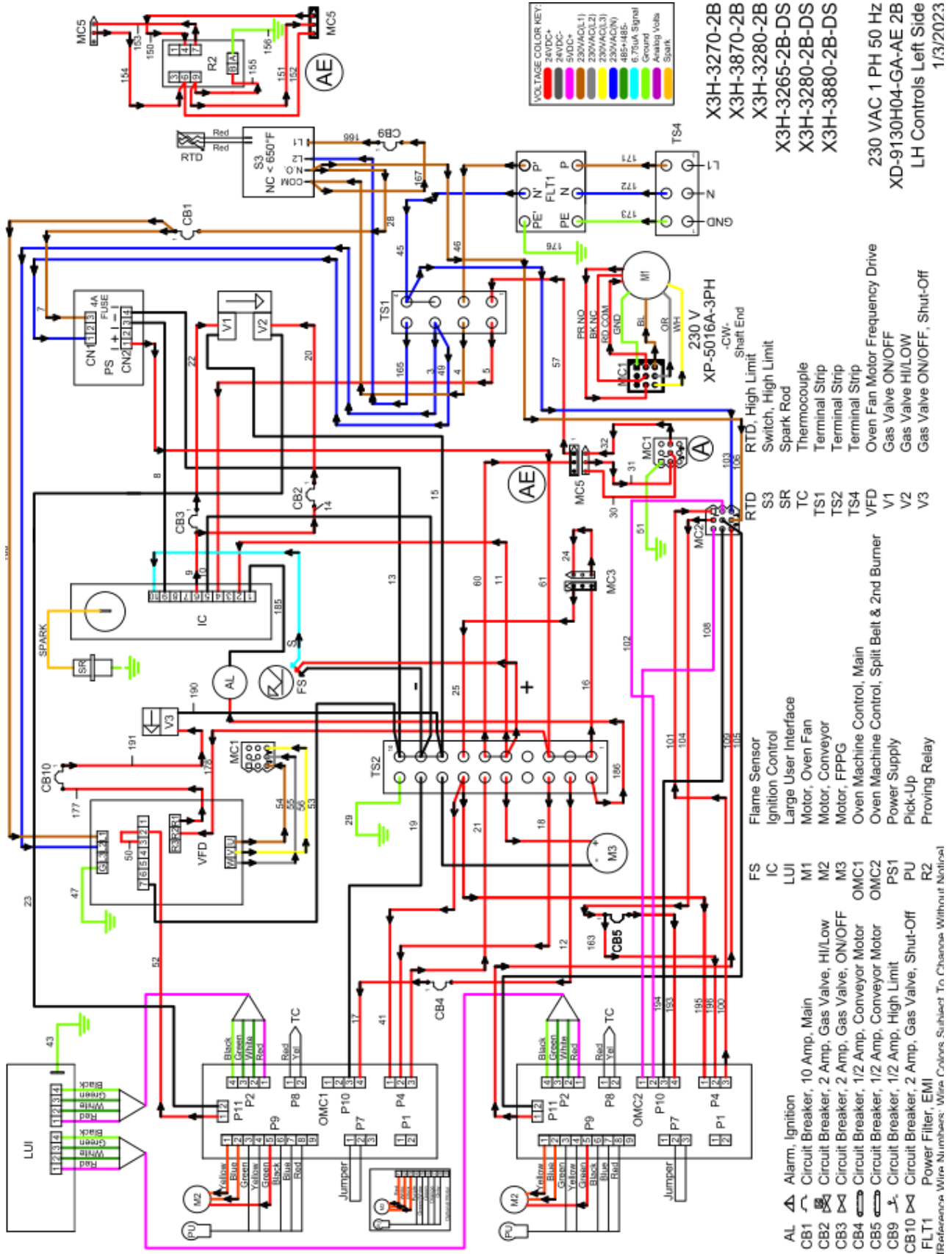

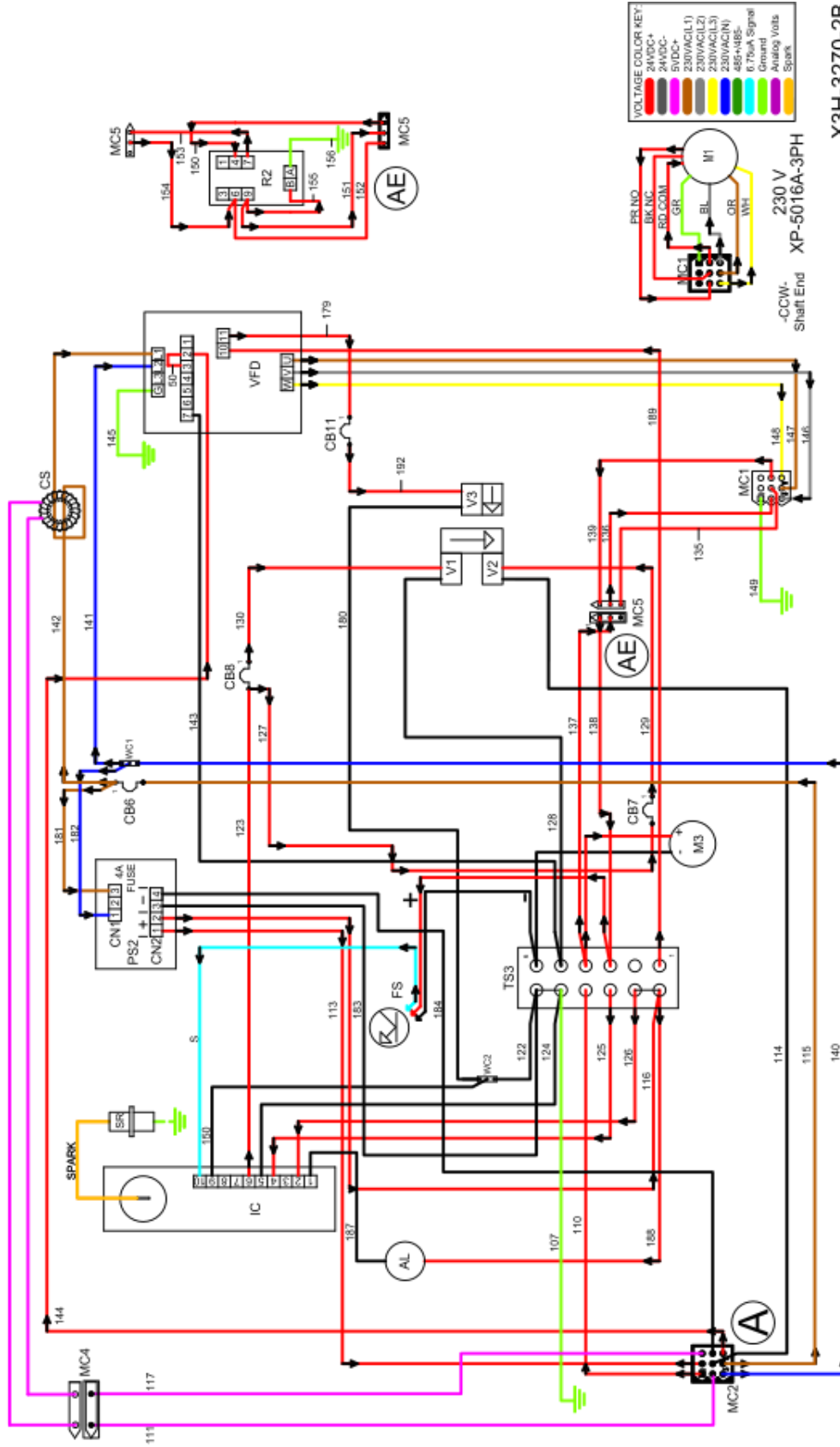

- X3H-3270-2B
- X3H-3870-2B
- X3H-3280-2B
- X3H-3265-2B-DS
- X3H-3280-2B-DS
- X3H-3880-2B-DS

230 VAC 1 PH 50 HZ
 XD-9130H04-GA-AE 2B
 LH Controls Right Side
 1/3/2023

- AL Alarm, Ignition
- CB6 Circuit Breaker, 10 Amp, Main
- CB7 Circuit Breaker, 2 Amp, Gas Valve, Hi/Low
- CB8 Circuit Breaker, 2 Amp, Gas Valve, ON/OFF
- CB11 Circuit Breaker, 2 Amp, Gas Valve, Shut-Off
- FS Flame Sensor
- IC Ignition Control
- M1 Motor, Oven Fan
- M3 Motor, FPPG
- PS2 Power Supply
- R2 Proving Relay
- SR Spark Rod
- TS3 Terminal Strip
- VFD Oven Fan Motor Frequency Drive
- V1 Gas Valve ON/OFF
- V2 Gas Valve HI/LOW
- V3 Gas Valve ON/OFF, Shut-Off
- WC1 Wago Connector
- WC2 Wago Connector

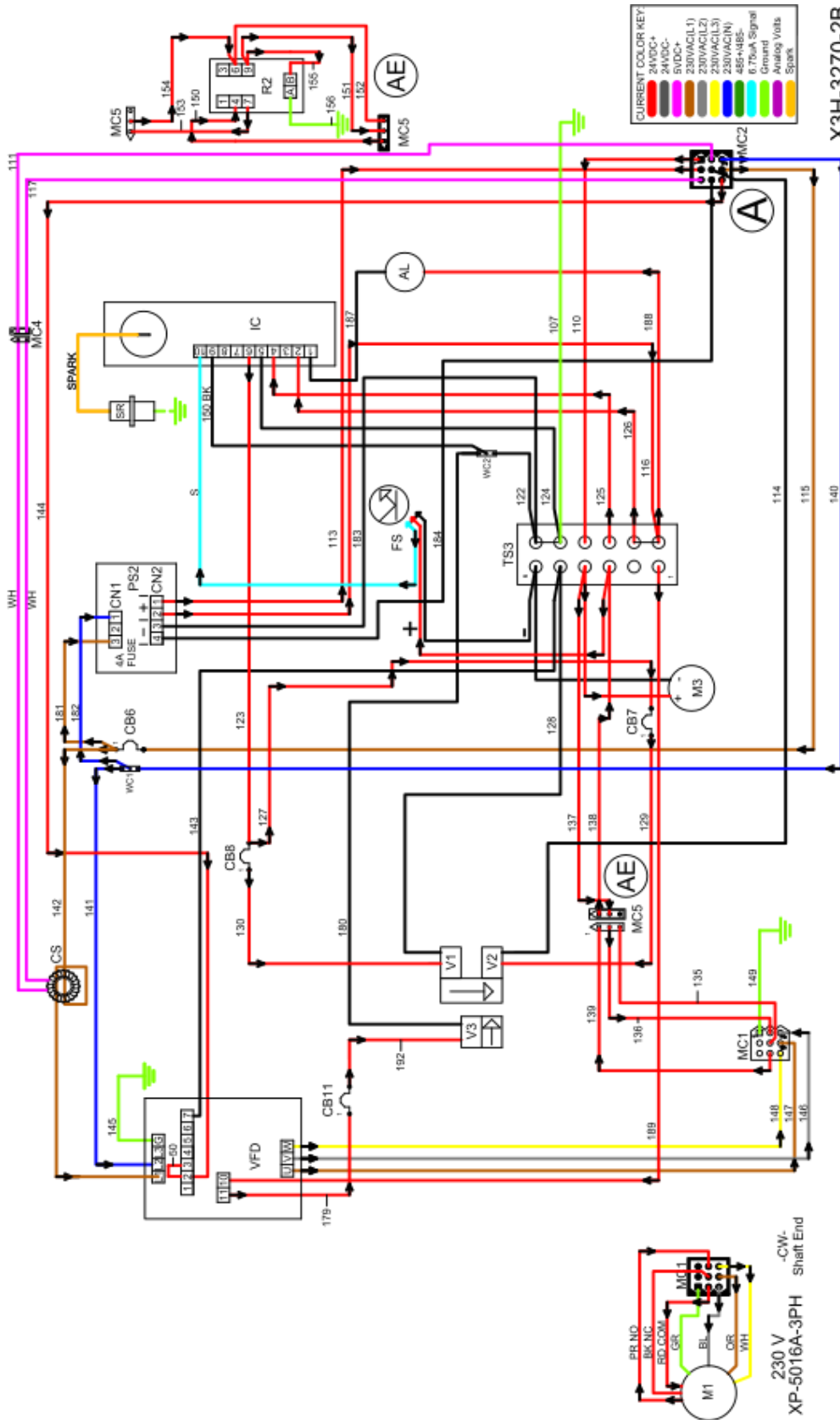

- X3H-3270-2B
- X3H-3870-2B
- X3H-3280-2B
- X3H-3265-2B-DS
- X3H-3280-2B-DS
- X3H-3880-2B-DS

230 VAC 1 PH 50 Hz
 XD-9130H04-GA-AE 2B RH
 RH Controls Left Side
 1/3/2023

- VFD Oven Fan Motor Frequency Drive
- V1 Gas Valve ON/OFF
- V2 Gas Valve HI/LOW
- V3 Gas Valve ON/OFF, Shut-Off
- WC1 Wago Connector
- WC2 Wago Connector

- M1 Motor, Oven Fan
- M3 Motor, FPPG
- PS2 Power Supply
- R2 Proving Relay
- SR Spark Rod
- TS3 Terminal Strip

- AL Alarm, Ignition
- CB6 Circuit Breaker, 10 Amp, Main
- CB7 Circuit Breaker, 2 Amp, Gas Valve, HI/LOW
- CB8 Circuit Breaker, 2 Amp, Gas Valve, ON/OFF
- CB11 Circuit Breaker, 2 Amp, Gas Valve, Shut-Off
- FS Flame Sensor
- IC Ignition Control

©Bafaranna Ultra-Miniature - Ultra Pulse Substant Tn, Phoenix, Without Notical

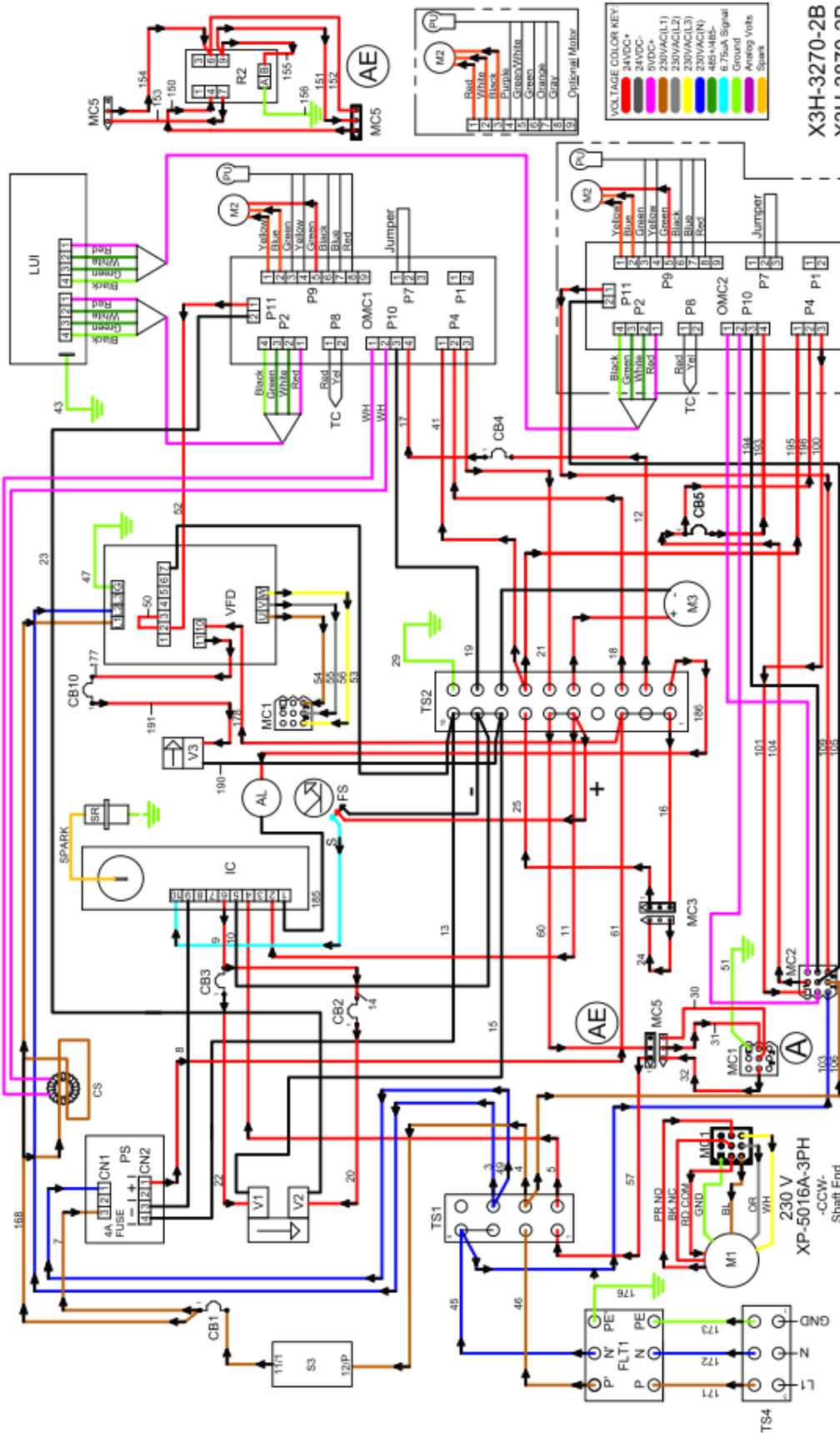

- AL** Alarm, Ignition
CB1 Circuit Breaker, 10 Amp, Main
CB2 Circuit Breaker, 2 Amp, Gas Valve, HI/Low
CB3 Circuit Breaker, 2 Amp, Gas Valve, ON/OFF
CB4 Circuit Breaker, 1/2 Amp, Conveyor Motor
CB5 Circuit Breaker, 1/2 Amp, Conveyor Motor
CB9 Circuit Breaker, 1/2 Amp, High Limit
CB10 Circuit Breaker, 2 Amp, Gas Valve, Shut-Off
FLT1 Power Filter, EMI
FS Proving Relay
IC Ignition Control
LUI Large User Interface
M1 Motor, Oven Fan
M2 Motor, Conveyor
M3 Motor, FPPG
OMC1 Oven Machine Control, Main
OMC2 Oven Machine Control, Split Belt & 2nd Burner
PS1 Power Supply
PU Pick-Up
R2 Proving Relay
RTD RTD, High Limit
S3 Switch, High Limit
SR Spark Rod
TC Thermocouple
TS1 Terminal Strip
TS2 Terminal Strip
TS4 Terminal Strip
VFD Oven Fan Motor Frequency Drive
V1 Gas Valve ON/OFF
V2 Gas Valve HI/LOW
V3 Gas Valve ON/OFF, Shut-Off
- X3H-3270-2B**
X3H-3870-2B
X3H-3280-2B
X3H-3265-2B-DS
X3H-3280-2B-DS
X3H-3880-2B-DS
- 230 VAC 1 PH 50 HZ**
XD-9130H04-GA-AE 2B RH
RH Controls Right Side
1/3/2023

References Wire Numbers: Wire Colors Subject To Change Without Notice

116 OVEN SCHEMATIC - AUSTRALIA NON VFD 2 BOX 230 VAC RHC LEFT SIDE

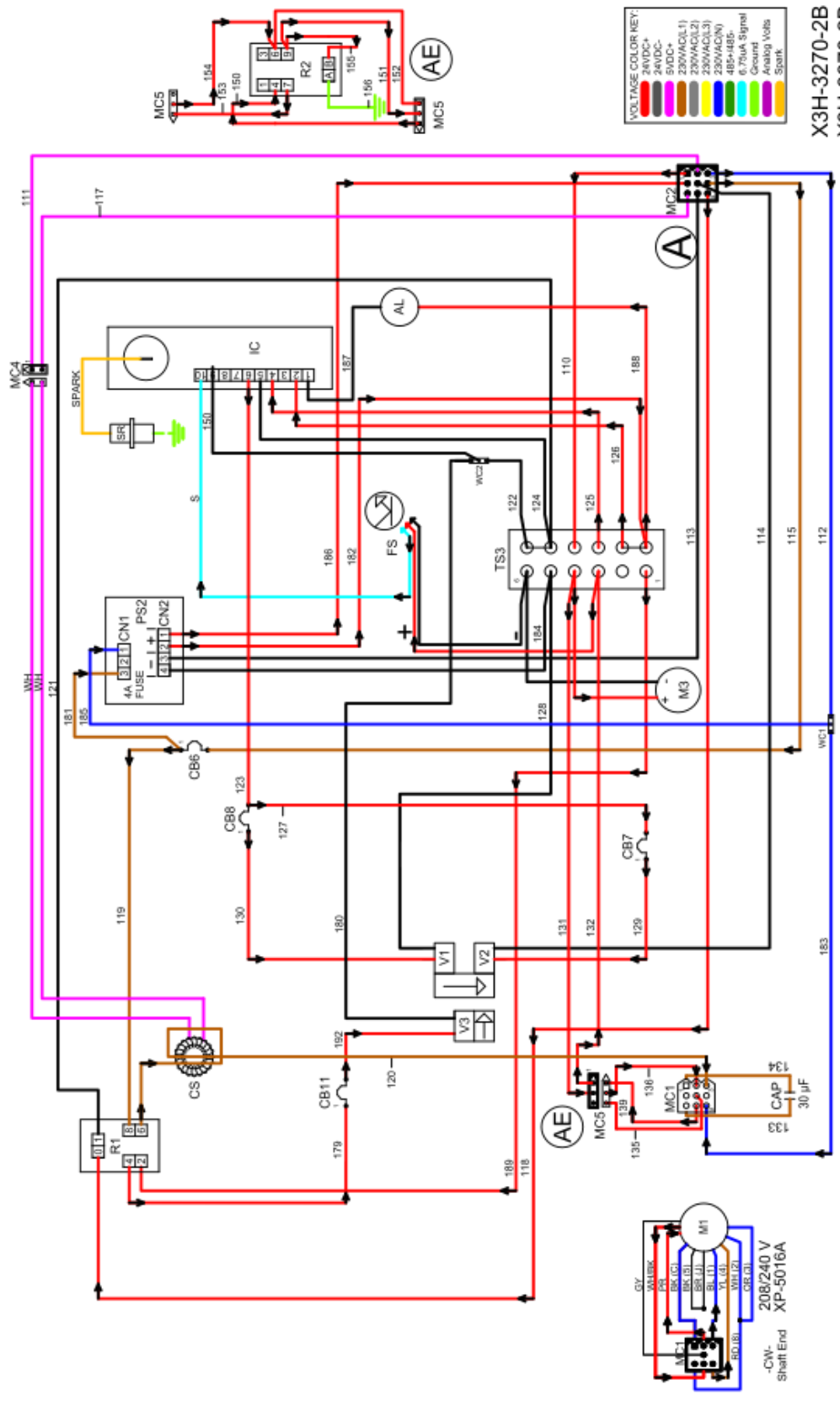

VOLTAGE COLOR KEY:

240VAC	230VAC(L1)	230VAC(L2)	230VAC(L3)	230VAC(N)	485-485	6.75uA Signal	Ground	Alarm Vols	Spark
5VDC+	5VDC-	230VAC(L1)	230VAC(L2)	230VAC(L3)	230VAC(N)	485-485	6.75uA Signal	Ground	Alarm Vols

- X3H-3270-2B
- X3H-3870-2B
- X3H-3280-2B
- X3H-3265-2B-DS
- X3H-3280-2B-DS
- X3H-3880-2B-DS

230 VAC 1 PH 50 Hz
 XD-9130H04-GA-NV-AE 2B RH
 RH Controls Left Side
 1/3/2023

- V1 Gas Valve ON/OFF
- V2 Gas Valve HI/LOW
- V3 Gas Valve ON/OFF, Shut-Off
- WC1 Wago Connector
- WC2 Wago Connector
- IC Ignition Control
- M1 Motor, Oven Fan
- M3 Motor, FPPG
- R1 Oven Fan Motor Relay
- R2 Proving Relay
- SR Spark Rod
- TS3 Terminal Strip

- CAP Capacitor 30µF
- CB6 Circuit Breaker, 7 Amp, Main
- CB7 Circuit Breaker, 2 Amp, Gas Valve, HI/Low
- CB8 Circuit Breaker, 2 Amp, Gas Valve, ON/OFF
- CB11 Circuit Breaker, 2 Amp, Gas Valve, Shut-Off
- CS Current Sensor
- FS Flame Sensor

[Reference Wire Numbers; Wire Colors Subject To Change Without Notice]

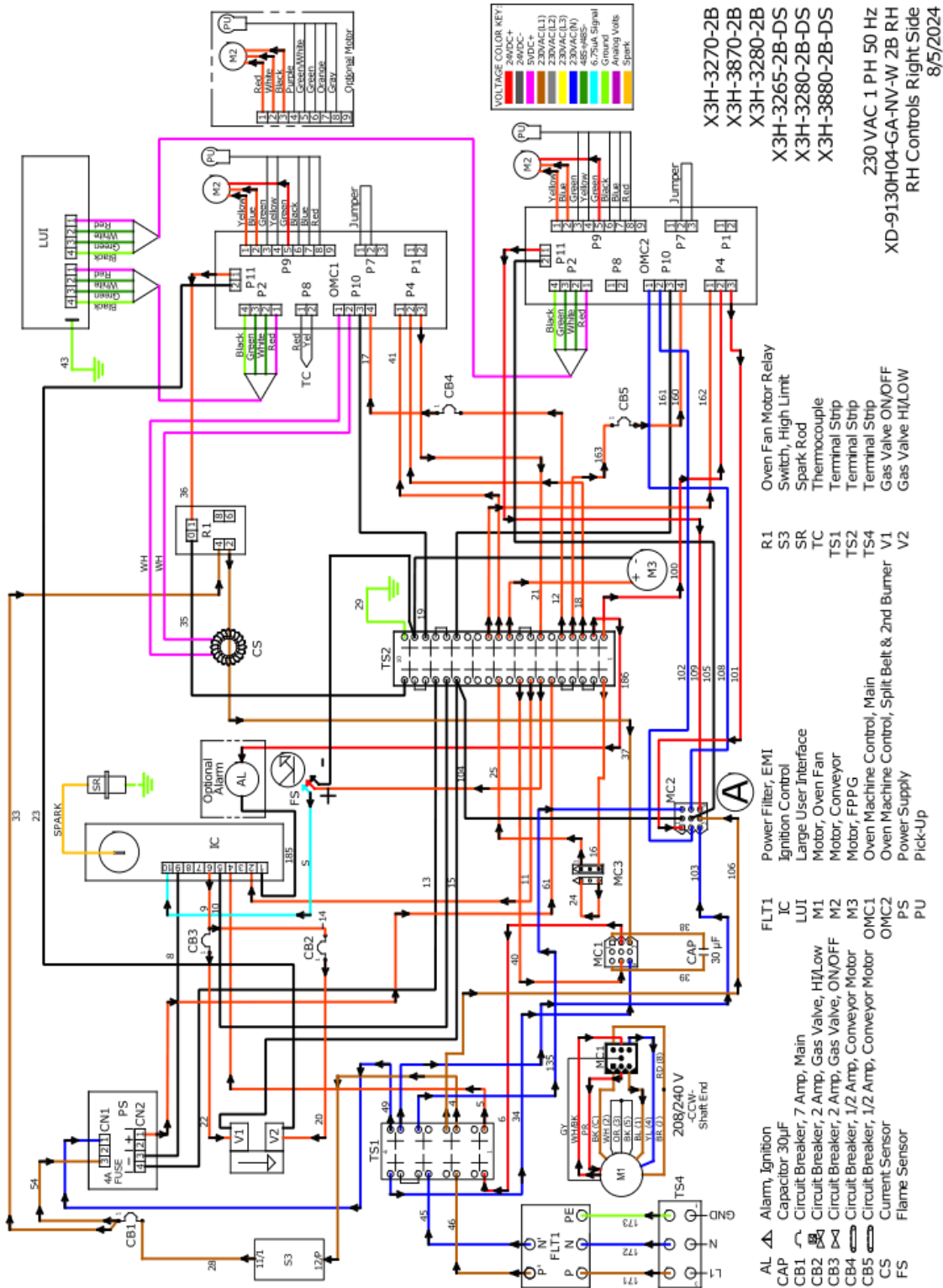

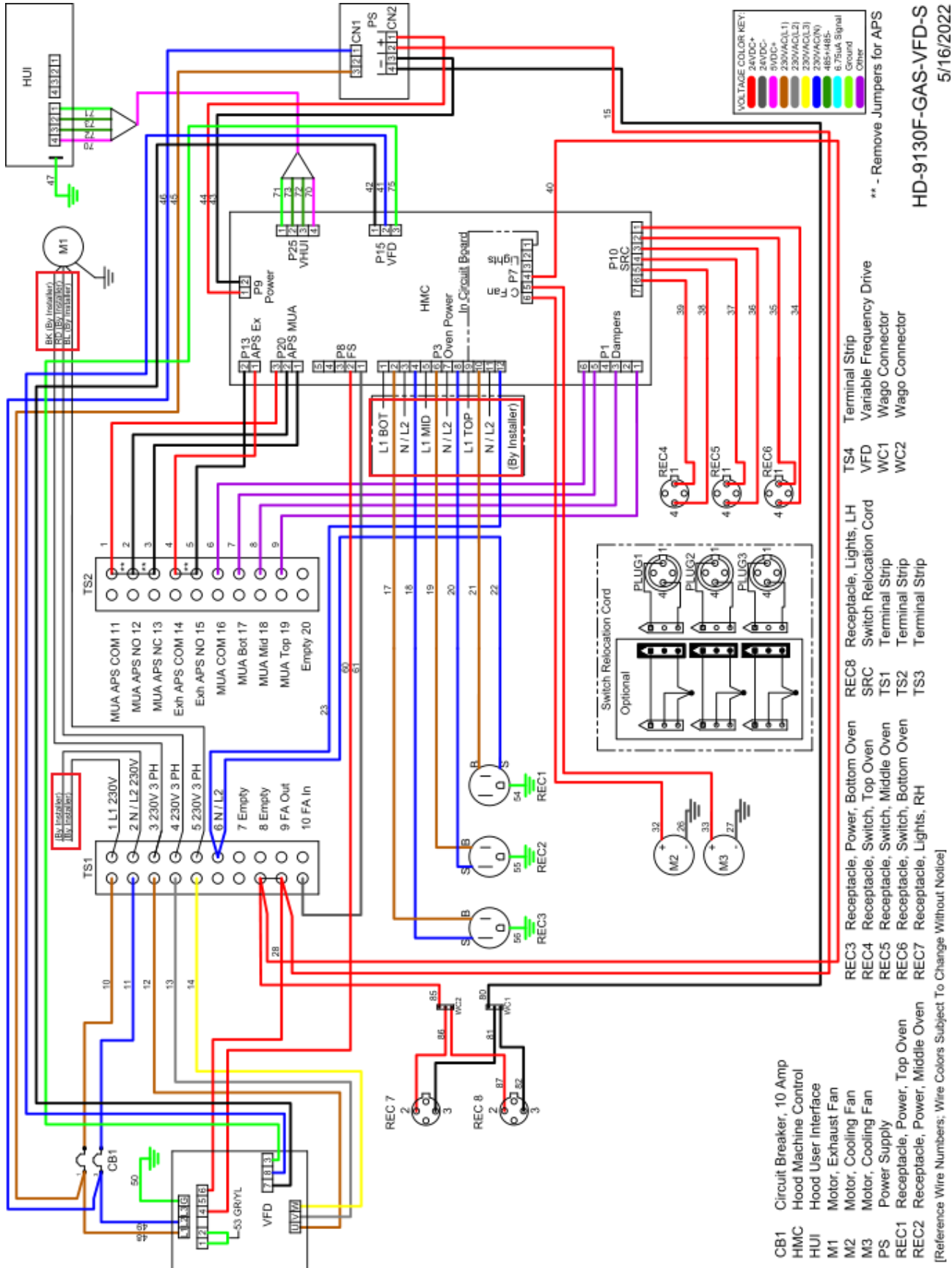

HD-9130F-GAS-VFD-S
5/16/2022

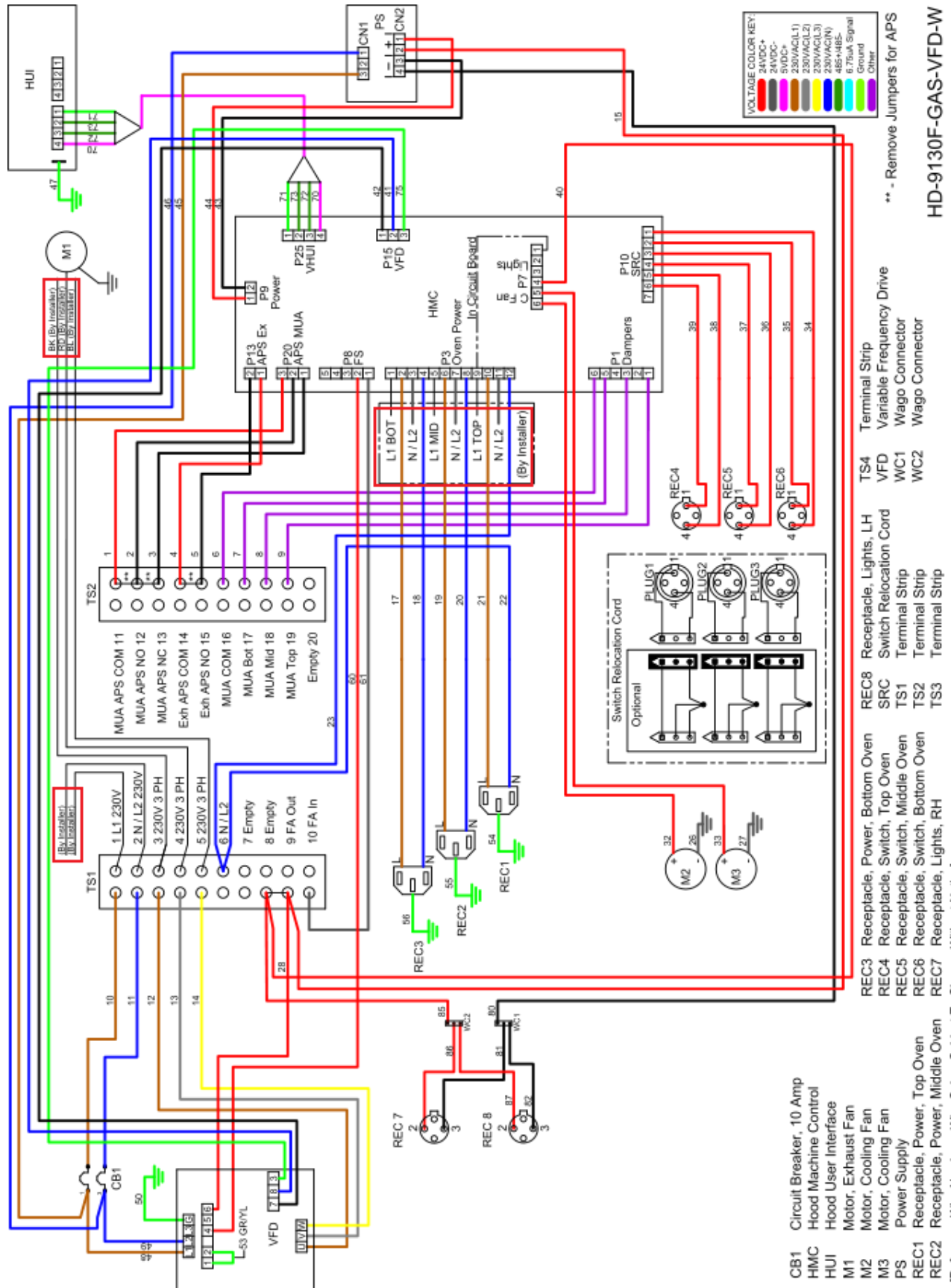

VOLTAGE COLOR KEY:

- 480VAC
- 240VAC
- 230VAC(L1)
- 230VAC(L2)
- 230VAC(L3)
- 485V485V
- 6.75uA Signal
- Ground
- Other

** - Remove Jumpers for APS

HD-9130F-GAS-VFD-W
5/16/2022

- CB1 Circuit Breaker, 10 Amp
- HMC Hood Machine Control
- HUI Hood User Interface
- M1 Motor, Exhaust Fan
- M2 Motor, Cooling Fan
- M3 Motor, Cooling Fan
- PS Power Supply
- REC1 Receptacle, Power, Top Oven
- REC2 Receptacle, Power, Middle Oven
- REC3 Receptacle, Power, Bottom Oven
- REC4 Receptacle, Switch, Top Oven
- REC5 Receptacle, Switch, Middle Oven
- REC6 Receptacle, Switch, Bottom Oven
- REC7 Receptacle, Lights, RH
- REC8 Receptacle, Lights, LH
- SRC Switch Relocation Cord
- TS1 Terminal Strip
- TS2 Terminal Strip
- TS3 Terminal Strip
- TS4 Terminal Strip
- VFD Variable Frequency Drive
- WC1 Wago Connector
- WC2 Wago Connector

[Reference Wire Numbers; Wire Colors Subject To Change Without Notice]

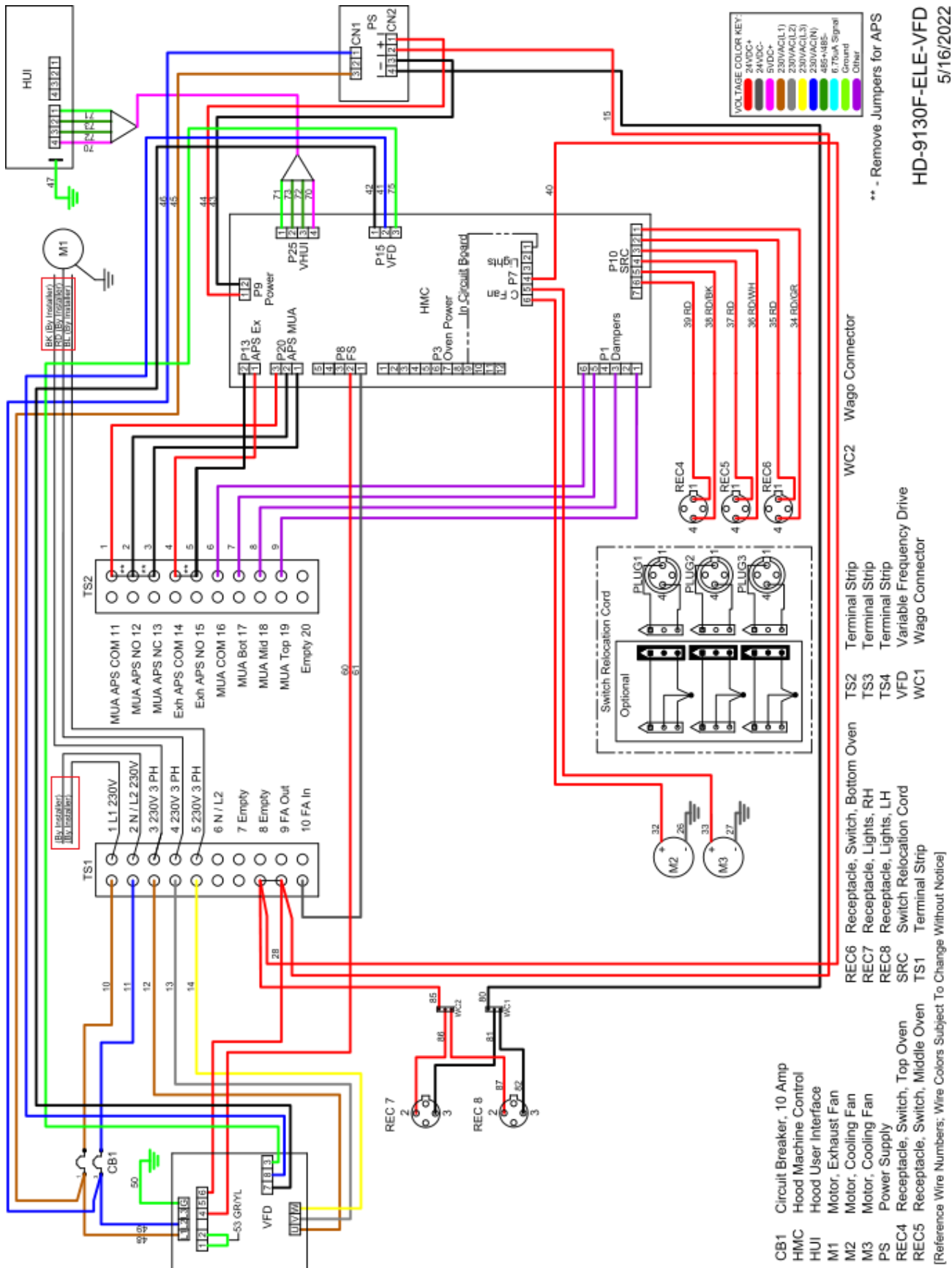

** - Remove Jumpers for APS

HD-9130F-ELE-VFD
5/16/2022



VOLTAGE COLOR KEY:

24VDC	Red
24VDC	Orange
230VAC(L1)	Blue
230VAC(N)	Green
Ground	Yellow

HD-9130F-NV
5/16/2022

- REC4 Receptacle, Top Oven
- REC5 Receptacle, Middle Oven
- REC6 Receptacle, Bottom Oven
- REC7 Receptacle, Lights, RH
- REC8 Receptacle, Lights, LH
- S2 Switch, Top Oven
- S3 Switch, Middle Oven
- S4 Switch, Bottom Oven
- TS1 Terminal Strip

[Reference Wire Numbers; Wire Colors Subject To Change Without Notice]

Product Certifications and Applicable Codes

Standard XLT Oven Certifications¹:

XLT Gas Ovens:

1. ANSI Z83.11-2016/CSA 1.8-2016 Standard for Gas Food Service Equipment
2. ANSI/NSF 4-2016 Sanitation for Commercial Cooking Rethermalization & Powered Hot Food Holding & Transportation Equipment

World XLT Oven Certifications¹:

XLT Gas Ovens:

1. EN 60335-1:2002 +A11, A1:2004 +A12, A2:2006 +A1 Low Voltage Directive (LVD)
2. EN 55014-1:2006 +A1:2009 +A2:2011 EN 61000-3-2:2018, EN 61000-3-3:2013 Electromagnetic Compatibility. (EMC)
3. EN 55014-2:2015 Conducted Emissions, Surge Immunity
4. BS EN 203-1:2014, Gas Heated Catering Equipment; General Safety Rules
5. BS EN 203-2-1:2006, Standard for Gas Heated Catering Equipment; Specific Requirements Ovens
6. BS EN 203-3:2009, Gas Heated Catering Equipment; Materials and Parts in Contact with Food and Other Sanitary Aspects
7. EN 60335-2-102:2004 +A1:2008 +A2:2012 Gas Appliance Regulation (GAR)

Australian XLT Oven Certifications²:

XLT Gas Ovens: (Certificate GAS40066)

1. AS 4563-2004 Commercial Catering Gas Equipment
2. AS/NZ 3350.1:2002 Safety of Household & Similar Appliances

Korea XLT Oven Certifications³:

XLT Gas Ovens: (Certificate GA-107)

1. Meets KGS-AB338 Facility/Technical/Inspection Code For Manufacture of Commercial Gas Burning Appliances.

Standard & World XLT Hood Certifications¹:

1. UL 710 Standard for Safety Exhaust Hoods for Commercial Cooking
2. ANSI/NSF 2:2014 Sanitation Food Equipment
3. ULC-S646, Standard for Exhaust Hoods and Related Controls for Commercial and Institutional Kitchens

¹ The noted certifications for XLT ovens and XLT Hood are performed and documented by Intertek Testing Services NA Inc. 165 Main Street, Cortland, NY 13045. Intertek is a nationally and internationally certified testing and accreditation agency.

² The certifications for Australia are administered and verified by the SAI Global Pty Limited 680 George Street, Sydney NSW 2000, GPO Box 5420 Sydney NSW 2001

³ 402 Hannuri-daero, Sejong-si, 339-012, Republic of Korea

Product Certifications and Applicable Codes

Australian XLT Oven Certifications²

XLT Gas Ovens: (Certificate GAS40066)

1. AS 4563-2004 Commercial Catering Gas Equipment
2. AS/NZ 3350.1:2002 Safety of Household and Similar Appliances

Korea XLT Oven Certifications³

XLT Gas Ovens: (Certificate GA-107)

1. Meets KGS-AB338 Facility/Technical/Inspection Code For Manufacture of Commercial Gas Burning Appliances.

Standard and World XLT Hood Certifications¹

1. UL 710 Standard for Safety Exhaust Hoods for Commercial Cooking
2. ANSI/NSF 2:2014 Sanitation Food Equipment
3. ULC-S646, Standard for Exhaust Hoods and Related Controls for Commercial and Institutional Kitchens

¹ The noted certifications for XLT ovens and XLT Hood are performed and documented by Intertek Testing Services NA Inc. 165 Main Street, Cortland, NY 13045. Intertek is a nationally and internationally certified testing and accreditation agency.

² The certifications for Australia are administered and verified by the SAI Global Pty Limited 680 George Street, Sydney NSW 2000, GPO Box 5420 Sydney NSW 2001

³ 402 Hannuri-daero, Sejong-si, 339-012, Republic of Korea

Oven Initial Start-up Checklist - Remove and Return to XLT Ovens

Fill out all information and print legibly

Start-Up Information Customer Name: _____ Company Name: _____ Phone #: _____ Email: _____ Address: _____ City: _____ State: _____ Zip: _____ Country: _____	
<p style="text-align: center;">Follow Requirements outlined in Installation and Operation Manual</p> <p><u>Oven Install and Start-up Requirements:</u></p> <ul style="list-style-type: none"> <input type="checkbox"/> Gas Requirements met (Gas Ovens Only) <ul style="list-style-type: none"> • One shut off valve per oven installed; if not, call XLT as this may void warranty <input type="checkbox"/> Electrical Requirements met <input type="checkbox"/> Clearances met <input type="checkbox"/> Oven(s) installed and stacked properly 	<p style="text-align: center;">Follow Requirements outlined in Installation and Operation Manual</p> <p><u>Hood Install and Start-up Requirements:</u></p> <ul style="list-style-type: none"> <input type="checkbox"/> Electrical Requirements met <input type="checkbox"/> Clearances/ Height Requirement met <input type="checkbox"/> Hood installed properly <input type="checkbox"/> Shrouds installed properly <ul style="list-style-type: none"> • Ovens are under hood with shrouds attached
<p>Oven Information</p> <p><u>Top Oven</u></p> Serial Number: _____ Model Number: _____ <p><u>Middle Oven</u></p> Serial Number: _____ Model Number: _____ <p><u>Bottom Oven</u></p> Serial Number: _____	<p>Hood Information</p> Serial Number: _____ Model Number: _____ <div style="text-align: right; padding-top: 20px;">  <p>XLT Ovens PO Box 9090 Wichita, KS 67277</p> </div>

Start-up can be submitted via mail, fax, email or submit online (using QR code above or go to xltovens.com/startup).

Print Name: _____ Signature: _____ Date: _____

XLTOvens
PO Box 9090
Wichita, Kansas 67277
US: 888-443-2751 FAX: 316-943-2769 INTL: +1-316-943-2751 WEB: www.xltovens.com